



Wireless Charging System and Mobile sensors: A Comprehensive Review

Taiwo Samuel Aina^{1*}, Oluwaseun Olanrewaju Akinte² and Babatunde Iyaomolere³

¹School of computer science and Technology, University of Bedfordshire, United Kingdom

²Department of Energy and Materials Engineering, Rajamangala University of Technology, Thailand

³Department of Electrical and Electronic Engineering, Olusegun Agagu University of Science and Technology, Nigeria

*Corresponding author: Taiwo Samuel Aina, School of computer science and Technology, University of Bedfordshire, United Kingdom

Received: 📅 July 05, 2023

Published: 📅 July 17, 2023

Abstract

Wireless charging systems have seen a rapid rise in medical devices, mobile sensing, consumer electronics, electric vehicles, and other applications due to their high operational flexibility. This paper aims at providing an in-depth systematic analysis of contemporary wireless charging and mobile sensor systems based on a comprehensive analysis of recent literature on the topic. The paper starts by describing the fundamental principles of wireless energy transfer, applications, and current challenges, followed by mathematical analysis, algorithms, simulation, and experimental results. Specifically, wireless power transfer (WPT) using inductive coupling, magnetic resonance, and radio frequency methods are studied to get a thorough understanding of the concepts. Compared to other similar studies, the focus is on healthcare and assisted living applications. The outcome of a thorough analysis of the relevant literature for a few chosen studies identified areas for improvement as well as new applications for the discipline [1-5].

Keywords: Energy harvesting; Mobile sensors IoT; Wireless charging system; WPT; Inductive charging; Magnetically Resonance Coupled Coupling; Radio frequency charging and theoretical analysis; Wireless Power Transfer System

Introduction

By 2050, the elderly are projected to make up more than 30% of the population in 64 nations, according to the United Nations. To track physical activity levels and promote active lifestyles, wearable devices (Jones, 2010) like activity trackers, smart phones pedometers and smartwatches can be used. Wearable sensor belts and heart rate measurement devices have become common, but some elderly people have chosen not to wear them due to personal preferences or other health issues. One drawback of wearable technology is its propensity for rapid battery drain. While having a low power consumption is important for wearable technology, the majority of wearables on the market today still require frequent battery recharges but elderly people may forget to charge the battery. In addition, the conventional wired method of charging has many drawbacks, including the effects on operational safety risks

and the prevention of mobility and mobilisation on a large scale to overcome this barrier, a wireless capabilities system must be created [6-9] While eliminating the restrictions of cables, wireless power transfer has the capacity to do the same task as a wired charger. For a complete charge to take as little as 30 minutes, some authors presented quick battery charging techniques wireless charging occurs in the typical vest storage location, and delivered power wirelessly to an implantable biomedical device, but the current fast charging technologies are expensive and difficult to operate. This research investigated wireless charging systems and mobile sensors, selecting papers through a comprehensive literature review. When compared to other reviews, this comprehensive review differs significantly in many ways. This analysis makes use of high-quality research articles published on the topic between 2007 and 2022, using a systematic approach in terms of technical

design concepts, mathematical analysis, algorithms, simulation, experimental, and theoretical knowledge. This section begins with a brief description of the research topic, then moves on to the principles of wireless energy transfer, applications, and current challenges, before concluding with the state of the art in wireless power transfer. Finally, the summary and conclusion of the review are discussed.

The Principles of Wireless Energy Transfer

Since Nicola Tesla’s first attempt over a century ago, WPT has had a long history. In a wireless charger, induction coils transmit and receive electrical current from the charger to the device. The fundamentals of WPT using inductive coupling, magnetic resonance, and radio frequency methods are discussed in this section, which serves as a background for the review literature [10-15].

Inductive Coupling

Energy is transferred through mutual induction in inductive coupling. It is effective across incredibly short distances. It is advantageous in that it is simple to implement, convenient, non-radiative, and has a low transmission frequency. At short distances, transmission efficiency is 95%. Induction coupling may only be used to charge a single receiver circuit; it cannot charge many devices at the same time. Below depicts the wireless power transfer transmitter and receiver. Two important components, known as the power transmitter and power receiver, are required to deliver wireless power. The primary coil and associated internal circuitry are carried by the base station, while the secondary coil and receiver circuit are carried by the portable target device. The transmitter serves as the charging station, while the receiver is built into the gadget to be charged. Power electronic converters deliver power from the receiver to the batteries or driving system in wireless power transfer systems [16-19]. Magnetic or inductive coupling between two coils is the key concept in wireless power transfer. The most common type of wireless charger today is electromagnetic induction. Mutual inductance controls the system’s transmission of energy and efficiency. Mathematically, the mutual inductance of two coils=

$$M_{12} = \frac{N_{12}\Phi_{12}}{I_1} \tag{2.1.1}$$

Where I_1 = primary coil current, N_{12} = secondary loop windings amount, Φ_{12} = electrical flux passing from primary coil to secondary coil.

Magnetic flux density and the area enclosed (A) Relationship =

$$\Phi_B = \iint \vec{B} \cdot d\vec{A} \tag{2.1.2}$$

According to Ampere’s law

$$\oint \vec{B} \cdot d\vec{l} = \mu i \tag{2.1.3}$$

Where B = magnetic flux density, i = net current and μ = permeability.

Where $\mu = \mu_0$ or

$$\text{From Biot – savart Law, } dB = \frac{\mu X i X dl X \sin \theta}{4\pi r^2} \tag{2.1.4}$$

Where infinitesimal length of conductor carrying the electric current i . and r = distance from the length element to the field point P.

Solution of (4) differential equals (2)

$$\Phi_B = \Phi \frac{dl}{\mu AXl} = i \tag{2.1.5}$$

In terms of reluctances Ampere’s law becomes

$$\Phi_B = \frac{i}{R_m} \tag{2.1.6}$$

Where $R_m = \text{reluctance of the magnetic loop. } \left[\frac{A}{w_b} \right] [R_m = \Phi \frac{dl}{\mu AXl}]$

Electromagnetic induction law of Faraday depicts that

$$\oint \vec{E} \cdot d\vec{l} = \frac{d\Phi_B}{dt} \tag{2.1.7}$$

Where, \mathcal{E} denote electromotive force and Φ_B magnetic flux.

The coils voltages are

$$v_1(t) = L_p \frac{di_1(t)}{dt} + M \frac{di_2(t)}{dt} \tag{2.1.8}$$

$$v_2(t) = L_s \frac{di_2(t)}{dt} + M \frac{di_1(t)}{dt} \tag{2.1.9}$$

The quantity of flux generated by the transmitter that reaches the coil is determined by the coupling factor (k).

$$k = \frac{M}{\sqrt{L_p L_s}} \tag{2.1.10}$$

In wireless transfer systems, wireless charging standards are necessary to avoid overloading, overheating, and heat transfer to neighboring objects. The Qi charging standard launched by the Wireless Power Consortium (WPC) allows a single charger to charge devices from a variety of manufacturers and has thus become a widely accepted method. Base stations and mobile devices are the two fundamental components of any Qi wireless charging system. The base station is the equipment that enables

wireless transmission using inductive power. Mobile devices, on the other hand, are those that utilize wirelessly delivered power. This is often used to charge the mobile device's battery [20-24].

Magnetically Resonance Coupled

The first conventional magnetically coupled resonance wireless power transfer concept was introduced by a research team from the Massachusetts Institute of Technology, and it could transfer 60 W with 40% efficiency over distances greater than 2 m they finished a fundamental experimental verification and published an article in the journal Science titled "Wireless Power Transfer through Strongly Coupled Magnetic Resonances" With this technology, electricity may be transmitted very deeply through barriers like bricks, wood, and plastic. with its performance in contactless charging areas like medical implants, mobile electronics, electric vehicles, and home appliances for its low radiation effect, high efficiency and midrange power transfer A lot of research has been done on magnetically coupled resonant wireless power transfer which uses coils that operate at the same resonance frequency to transmit power from a source to a load. The operating frequency is in the hundreds of kHz to tens of MHz range. When compared to inductively coupled wireless power transfer magnetically coupled resonance wireless power transfer has higher transfer power and efficiency and is now considered one of the most potent techniques for mid-range WPT applications Magnetic resonator coupling has the benefits of not being affected by environmental weather, transferring several meters of energy, not requiring alignment between the transmitter and receiver coils, not requiring line-of-sight (LOS) when devices are charged, and having high transfer efficiency under an omnidirectional antenna As shown in a magnetically coupled resonant wireless power transfer system consists of four coils: a driving loop, a transmitting resonator, a receiving resonator, and a load loop on either side of the receiver While the load loop is attached to the item that has to be charged, the driving loop is powered by an electric source [25-30].

The resonators, which can be capacitively loaded or self-resonant, are viewed as two RLC tank circuits. Additionally, extraneous objects can quickly change the resonance frequency. Inductive coupling is used to transport power from the driving loop to the transmitting resonator loop, and then it is magnetically linked to Magnetically resonance-coupled wireless power transfer uses two resonant circuits, one of which serves as a transmitter and the other as a receiver, and both of which have the same resonant frequency. The coils in the circuits are positioned in such a way that non-radiative magnetic resonance induction can firmly couple them, Inductors and capacitors can be arranged in series or parallel to create resonating circuits below depicts the series resonance circuit structure of the equivalent circuit for coupled resonators. From the equivalent circuit of coupled resonator system, the parameters are defined as follows

The load resistance transmitted and the available maximum source power mathematically gives

$$P_L = 4U^2 \frac{R_g}{R_s} \frac{R_L}{R_d} \tag{2.2.1}$$

$$P_{g,max} = [(1 + \frac{R_g}{R_s})(1 + \frac{R_L}{R_d}) + U^2]^2 \tag{2.2.2}$$

Circuit yield when the resonator system are coupled strongly can be deduced from ratio of to

$$\frac{P_L}{P_{g,max}} = \frac{4U^2 \frac{R_g}{R_s} \frac{R_L}{R_d}}{[(1 + \frac{R_g}{R_s})(1 + \frac{R_L}{R_d}) + U^2]^2} \tag{2.2.3}$$

$$U = \frac{\omega M}{\sqrt{R_s R_d}} = k \sqrt{Q_s Q_d} \tag{device and source} \tag{2.2.4}$$

$$\frac{R_g}{R_s} \frac{R_L}{R_d} = \sqrt{1 + U^2} \tag{2.2.5}$$

Transfer efficiency power will be.

$$\eta_{opt} = \frac{U^2}{(1 + \sqrt{1 + U^2})^2} \tag{2.2.6}$$

The figure below depicts a magnetic coupling circuit. With this circuit, the equivalent impedance equations are deduced assuming $C = C_1 = C_2$ in the resonance coupling system, written in such a way that the electrical efficiency is calculated

$$V_1 = I_1(R + jL_1\omega + (\frac{1}{j\omega C})) - I_2(jL_m\omega) \tag{2.2.7}$$

$$0 = I_2(jL_2\omega + (\frac{1}{j\omega C}) + Z_0 + R) - I_1(jL_2\omega) \tag{2.2.8}$$

$$I_2 = I_1(jL_2\omega + (\frac{1}{j\omega C}) + Z_0 + R) - I_1(jL_2\omega) \tag{2.2.9}$$

$$I_2 = I_1[\frac{jL_m\omega}{jL_2\omega + (\frac{1}{j\omega C}) + Z_0 + R}] \tag{2.2.10}$$

$$V_1 = I_1(R + jL_1\omega + (\frac{1}{j\omega C})) - I_1[\frac{jL_m\omega}{jL_2\omega + (\frac{1}{j\omega C}) + Z_0 + R}](jL_m\omega) \tag{2.2.11} [51]$$

$$V_1 = I_1(R + jL_1\omega + (\frac{1}{j\omega C})) - I_1[\frac{j^2L_m^2\omega^2}{jL_2\omega + (\frac{1}{j\omega C}) + Z_0 + R}] \tag{2.2.12}$$

$$Z_{Eq} = Z_1 = R + jL_1\omega + (\frac{1}{j\omega C}) + [\frac{L_m^2\omega^2}{jL_2\omega + (\frac{1}{j\omega C}) + Z_0 + R}] \tag{2.2.13}$$

$$Z_{Eq} = R + jL_1\omega + (\frac{1}{j\omega C}) + [\frac{L_m^2\omega^2}{jL_2\omega + (\frac{1}{j\omega C}) + Z_0 + R}] + jL_m\omega - jL_m\omega \tag{2.2.14}$$

$$Z_{Eq} = R + (\frac{1}{j\omega C}) + j(L_1 - L_m)\omega + \frac{-j^2L_m^2\omega^2 + j^2L_2\omega^2 + jL_m\omega(Z_0 + R) + jL_m(\frac{1}{j\omega C})\omega}{jL_2\omega + (\frac{1}{j\omega C}) + Z_0 + R} \tag{2.2.15}$$

$$Z_{Eq} = R + (\frac{1}{j\omega C}) + j(L_1 - L_m)\omega + \frac{(jL_m\omega) + j(L_2 - L_m)\omega + (\frac{1}{j\omega C})Z_0 + R}{jL_2\omega + (\frac{1}{j\omega C}) + Z_0 + R} \tag{2.2.16}$$

$$Z_{Eq} = R + (\frac{1}{j\omega C}) + j(L_1 - L_m)\omega + \frac{1}{\frac{jL_2\omega + (\frac{1}{j\omega C}) + Z_0 + R + jL_m\omega - jL_m\omega}{jL_m\omega(j(L_2 - L_m)\omega + (\frac{1}{j\omega C})Z_0 + R)}}$$

$$Z_{Eq} = R + (\frac{1}{j\omega C}) + j(L_1 - L_m)\omega + \frac{1}{\frac{1}{jL_m\omega} + \frac{1}{(j(L_2 - L_m)\omega + (\frac{1}{j\omega C})Z_0 + R)}}$$

The ratio of P_{out} and P_{in} gives equation of efficiency.

$$\eta = \frac{P_{out}}{P_{in}} = \frac{I_2 Z_{out}}{I^2 in^Z Eq}$$

$$I_2 = I_1[\frac{jL_m\omega}{jL_2\omega + (\frac{1}{j\omega C})Z_0 + R}] \tag{From equation (10)}$$

which on change of subject of formula gives

$$\frac{I_{out}}{I_{in}} = \frac{jL_m \omega}{jL_2 \omega + (\frac{1}{j\omega C})Z_0 + R}$$

Substituting (19) and (13) in equation (18)

$$\eta = \left(\frac{jL_m \omega}{jL_2 \omega + (\frac{1}{j\omega C})Z_0 + R} \right)^2 = \frac{Z_0}{[R + jL_1 \omega + (\frac{1}{j\omega C}) + [\frac{L_m^2 \omega^2}{jL_2 \omega + (\frac{1}{j\omega C}) + Z_0 + R}]}$$

The three system efficiency conditions are Maximum efficiency condition,

Double resonance frequency condition and Single resonant frequency at low efficiency level condition.

Maximum efficiency condition

$$L_m^2 = \frac{Z_0^2 - R^2}{\omega_0^2}$$

Double resonance frequency condition.

$$L_m^2 > \frac{Z_0^2 - R^2}{\omega_0^2}$$

Single resonant frequency at low efficiency level condition

$$L_m^2 < \frac{Z_0^2 - R^2}{\omega_0^2}$$

Radio Frequency

Depending on the technology, radio frequency wireless power transfer can transmit power over distances ranging from a few metres to several kilometres by transmitting the radiant energy emitted by an antenna. It requires line of sight to supply power, has a very poor efficiency rate, and has limited application. Radio-frequency wireless power transfer relies heavily on an understanding of electromagnetic waves. The behaviour of electromagnetic waves changes with respect to the environment's conductivity, frequency, and distance illustrates the basic elements of a radio-frequency wireless power transfer Table 1-4.

Table1: The load resistance transmitted, and the available maximum source power mathematically gives.

Acronyms	Parameters
Vg	Voltage source amplitude
	Internal resistance(Source)
	Mutual inductance
	Source resonator coils
	device resonator coils
and	unwanted resistance (including ohmic and radiation losses) in the coil and the resonance capacitor for each resonator
	AC load resistance
K	coupling coefficient

Table 2: Wireless Power Transfer System: Experimental Research.

Ref	Application	Methodology/ technology	Efficiency/limitation	Year
(Soni and Shrivasta [11])	Rechargeable Mobile wireless sensor network	(R L) Reinforcement learning	According to simulation data, the proposed charging algorithms significantly improved the node failure rate and network lifetime when compared to existing methods.	2019
Chen et al., [15]	Wireless rechargeable sensor networks	Double-side charging techniques	Delaunay triangulation and Voronoi diagram integrated clustering technologies are all compatible with the offered strategies.	2022

Xie et al., [12]	Sensor node batteries	Mathematical model of a Wireless Charging	The main drawback of this work is that the route taken by the wireless charging truck has been preplanned.	2015
Xu, Cheng and Wu, [14]	Wireless Rechargeable Sensor Network(s)	Scheduling algorithm	Limited in number recollected chargers in the simple backward charger recollecting algorithm and a bit stricter simulation condition limitation	2018
Ruhul, Amin and Roy, [17]	Hybrid electric vehicle	Inductive power pad	Approximately 95% power transfer efficiency.	2014
Zhang, [22]	Wireless charger	Mathematical analysis and wireless technology	The outcome of this work indicate that it can replace wired chargers in small appliances at 99%.	2021
Wang et al., [5]	Wireless Rechargeable Sensor Network(s)	Low latency mobile data gathering scheme and a mathematical model	The simulations showed the adaptive algorithm achieved both low latency and high energy efficiency.	2016
Chen et al. [7]	Wireless charging coil with magnetizers	Simulation using COMSOL	18-63 Kw power transfer with efficiency of 88.7% - 92.7% at 45 cm transfer distance	2019
Gonzalez-Gonzalez, Trivino-Caberera and Aguado [27]	Wireless Electric Vehicle	Control Algorithm	The simulations have been made with the maximum primary current limit established in 15 Amps and a reference charging power of 3.7 kW, that is to say, the maximum power allowed by the implemented charger.	2017
Han et al., [29]	IoT	Mobile charging algorithm.	MCCA can effectively balance energy consumption according to simulation result	2020
Truong et al., [9]	Series-series topology magnetic coupling	Mathematical model based on circuit theory	The efficiency of the WPTS under investigation might attain a high level without the need of any optimization methods.	2019

Table 3: Magnetic Resonance based Wireless Power Transfer System.

Ref	Application	Methodology/ technology	Efficiency/limitation	Year
Li and Bashirullah [8]	Rechargeable batteries	The wireless power interface employs an integrated Schottky barrier diode rectifier	The circuit measures roughly 1.74 mm ² and dissipates 8.4 mW in the charging phase while delivering a load current of 1.5 mA at 4.1 V (or 6.15 mW) for an efficiency of 73%.	2007
Moon et al., [11]	Wearable medical device	Wireless charger integrated circuit	Compared to the amount of electricity pulled from the battery, the charging station's total efficiency is 13.1 %, which is an exceedingly excellent result.	2015
Mayordomo et al., [14]	Wireless sensor networks	Inductive coupling	There are still many research challenges to be addressed in order to achieve a successful implementation of inductively coupled wireless power transfer which can be worked on by other researcher	2013
Heo et al., [19]	Researchers and application engineers	Exhaustive insight and detailed discussion on the components of a systems having Wireless Power Transfer (WPT) and the various techniques used for its implementation.	The current implementations of this concept are limited due the radiative nature of the fields involved in long distance transfer of power	2018

Table 4: Inductive Charging.

Ref	Application	Methodology/ technology	Efficiency/limitation	Year
Deyle and Reynolds [13]	Bidirectional communication	Magnetic flux coupling	The system enables continuous operation of a swarm-sized population of battery-less robots	2008
Kuo et al., [6]	Wearable device and mobile phone	A planar and three-dimensional coil structure	In this prototype system, wearable gadget and mobile phone simultaneously sends 1 W and 5 W respectively with an efficiency of power transmission of 48 %	2015

Aswin et al., [24]	For insufficient power supply and power outages in remote area	Maximum Power Point Tracking	One disadvantage of this project is that it may be challenging to generate enough power due to its solar nature.	2022
Oyeleke et al., [2]	Mobile phone	Transmitter with a resonator and a receiver with a resonator	The limitations of this system include a maximum charging distance of about 3 cm, heating of the resonant capacitor and flux wastages due to unguided radiation of EM waves.	2019
Wang et al., [21]	Wireless power transfer	Theoretical analysis and experimental verification.	The study demonstrated that SP topology I is the topology that is best suited for use in WPT.	2019

Table 5: Radio frequency charging and theoretical analysis.

Ref	Application	Methodology/ technology	Efficiency/limitation	Year
Low et al., [20]	Class E transmitter	Inductive coupling	The provided power and efficiency include 295W at a 75.7% efficiency and 69W power at a 74.2% efficiency for cooling and convection, respectively.	2009
Wielandt et al., [18]	Medical measurements	Inductive Charging	The result gives a charging efficiency of 90 %.	2015
Paramesh, Neriya and Kumar [8]	Electric vehicle batteries	Power electronics simulations.	Using the experimental data, it was possible to attain a coupling efficiency of 79% at a level of about 100 W.	2017
Zhang [2]	Wireless rechargeable sensor networks	Greedy algorithm, adaptive algorithm and mathematical model	The adaptive method achieves minimal latency and excellent energy efficiency when compared to other techniques.	2021

In far-field free space, receiver antenna power [55] =

$$P_R = \frac{P_T G_T G_R \lambda^2}{(4\pi R)^2} \tag{2.3.1}$$

$$= \frac{(4\pi f R)^2}{G_T G_R c^2} \tag{2.3.4}$$

$$= \frac{4}{G_T G_R c^2} (kR)^2 \tag{2.3.5}$$

where P_R = receiver antenna power

In dBi, the equation becomes.

G_R (dBi) = Receiver antenna gain

$$P_L (dB) = 20 \log_{10}(f) + 20 \log_{10}(R) + 20 \log_{10}\left(\frac{4\pi}{C}\right) - G_T - G_R \tag{2.3.6}$$

λ = wavelength of electromagnetic signal

[55]

The free space pathloss, P_L for far-field can be deduced.

f (MHz)= frequency, R (km) = distance, (dBi)= Transmitter gain and (Trevisan and Constanzo, 2014).

$$P_L = \frac{P_T}{P_R} \tag{2.3.2}$$

$$P_L (dB) = 20 \log_{10}(f) + 20 \log_{10}(R) + 32.44 - G_T - G_R \tag{2.3.7}$$

$$= \frac{(4\pi R)^2}{G_T G_R \lambda^2} \tag{2.3.3}$$

Signal power at the far field region can be indicated by using pathloss equation

Applications and Current Challenges

Application

Wireless charging is used in a variety of devices such as mobile phones, electric vehicles, medical electronic devices, military, smart homes, trains, and so on.

Mobile Applications

WPT found applications in mobile phones. Mobile gadgets, including smartphones, tablets, and smartwatches, are now used in record numbers. The typical charging mechanism can be changed with WPT, which makes it possible to charge a laptop or smartphone continuously without having to connect anything, like with cable charging Table 5.

Medical Electronic Devices

In the field of biomedicine WPT is used to transmit energy to implantable gadgets and biomedical sensors. Medical implants WPT for cochlear implants, which is the most widespread application and enables deaf people to regain their hearing abilities with the aid of hearing aids. The implant itself, which is buried beneath the skin, is what makes up the cochlear hearing system. Energy is sent to the implant through an inductively coupled link through the skin from an external device behind the ear that also features a microphone and a signal processing unit. The use of WPT for cochlear implants permits the external device's battery to be changed.

Military

Scientists have successfully used WPT to improve the security and dependability of numerous gadgets, as well as weapons used both on and off the battlefield. It has assisted in reducing the requirement for batteries, which has long been a burden for both manned and robotic vehicles as well as soldiers engaged in combat. Recently, prototypes were created to transmit power wirelessly from the soldier's vest-mounted battery to the electronics mounted on the helmet as well as additional devices like radios and night vision. In order to create a stable communication link with our submarines, new breakthroughs in wireless acoustic communication have also been made (Benerji et al., 2016).

Smart Cities, and trains

Wireless power transfer is applied in smart cities, where a transmitter transmits electricity from a power plant and a receiver receives the power to supply electricity to homes and trains. Future trains might be powered wirelessly. In this setup, a dual-mode power receiver and transmitter will be connected to the pole. A pole with a dual-mode transmitter and receiver will be present at each station. Power comes from a power plant, and a dual-mode transmitter both captures and transmits the power. When a dual-mode transmitter is in use, both transmission and reception take place at once. The receiver mounted on the train's roof will be the one to receive these powers.

Research Challenges

The challenges of inductive coupling, magnetically coupled, and radio frequency WPT are.

Alignment or Orientation

The practical issue of alignment or orientation between the source and destination coils is present in inductive coupling and magnetic resonant coupling systems. The coaxial alignment between the coils must be guaranteed in order to achieve the greatest transfer distance. Other alignment configurations, such as a 45° rotation or coplanar positioning with respect to the coaxial alignment, minimize the coupling between the receiving and transmitting coils, reducing the transfer range and efficiency.

Environmental factor

Wireless devices' performance is continually influenced by the materials around them. This typically entails interfering with the transmitting and receiving antennas' radiation patterns and/or the field's propagation. In many circumstances, the deterioration will be insignificant, but depending on the type of substance, the connection may occasionally be completely hampered.

Health and Security

When operating at high frequencies, the WPT may present difficulties for therapeutic applications. The working frequency of the RF WPT must be raised to the GHz band in order to achieve high power transfer and a reduced receiving coil size. To achieve the desired transfer power delivery efficiency in this band, perfect impedance matching is needed in both the receiving and transmitting circuits.

Transfer power problem

The wireless charging of portable electronic devices was made possible by the WPC's "Qi" standard, version 1.1, which has a limited transmission power of up to 5 W. This is appropriate for the wireless charging of a wide variety of low-power gadgets, including mobile phones, Bluetooth earpieces, iPods, and so forth. Future standards are anticipated to increase the transfer power capabilities to 120 W, allowing for the coverage of more mobile devices such as laptops and iPads. Numerous real-world difficulties will arise as a result of the increase in wireless power transfer, particularly regarding the electromagnetic field, electromagnetic compatibility, and thermal issues.

Mobility

Mobile sensing systems are challenging due to limited energy storage capacity and increased energy demand. Therefore, energy harvesting seems like a suitable choice. However, charging mobile nodes can bring other (specific) challenges. This is due to the limited charging range and the fact that nodes can move away while charging. An example of such interesting problems or scenarios is optimal route selection for mobile chargers.

Wireless Power Transfer: State of The Art

Wireless charging systems and mobile sensors: a comprehensive literature review has been done in this research from the top scientific research search engines in this subject, including Google Scholar, Web of Science, The IEEE Wireless Power Conference, Science Direct, and IEEE Explore. Papers that were relevant were found between 2007 and 2022 using these

web databases. This review of the research literature is organised into several subsections. Section 4.1: Simulation, algorithm, and mathematical model; Section 4.2: Wireless Power Transfer System application and challenges; Section 4.3: Magnetic Resonance-based Wireless Power Transfer System; Section 4.4: Inductive Charging; and Section 4.5: Radio Frequency Charging and theoretical analysis Figure 1-3.

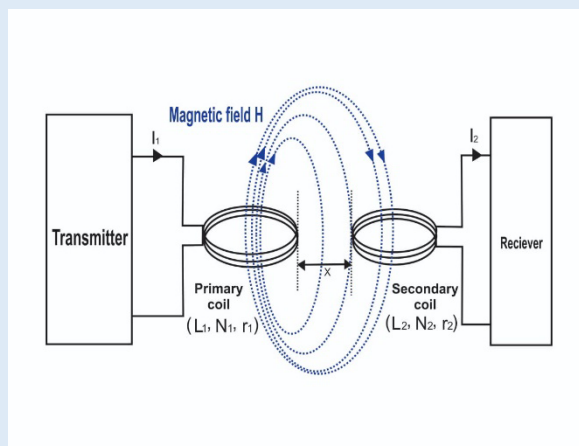

Figure 1: Basic principle of inductive coupling

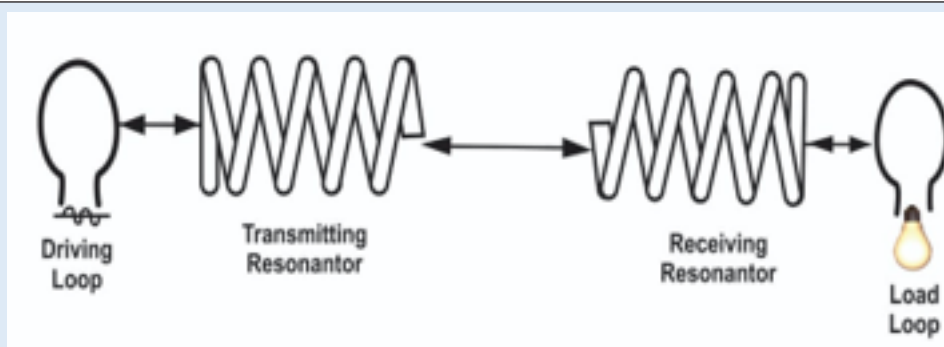

Figure 2: Schematic diagram of a typical magnetically coupled resonant wireless power transfer (Peng, 2018).

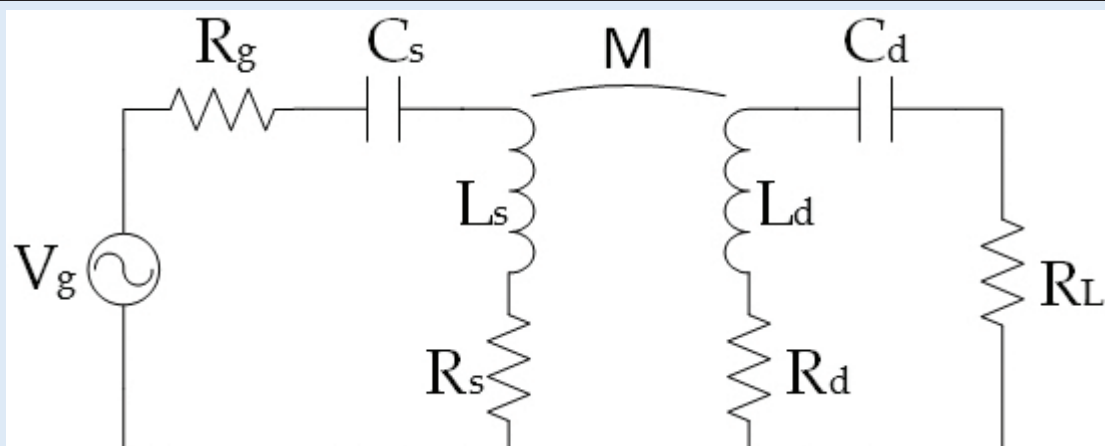

Figure 3: Equivalent circuit of coupled resonator system.

Simulations, Algorithms and Mathematical Modeling

Mobile and fixed charging techniques are proposed. The study described how sensor nodes might get wireless power from either a stationary or mobile wireless charger. By employing reinforcement learning to improve charge pathways and cut costs, this work made significant advancements in the field. According to simulation data, the proposed charging algorithms significantly improved the node failure rate and network lifetime when compared to existing methods. In a wireless rechargeable sensor network makes use of technologies that enable mobile devices to charge simultaneously from both sides. The work demonstrated that Delaunay triangulation and Voronoi diagram integrated clustering technologies are all compatible with the offered strategies. presented a mobile platform that uses wireless energy transmission to replenish sensor node batteries. This research demonstrates how to use a single mobile platform to combine wireless energy transfer with sensor network data collection. The main drawback of this work is that the route taken by the wireless charging truck has been preplanned. proposed a new wireless rechargeable sensor network model that provides a single charging vehicle with a separable charger array along with a wireless charging scheduling strategy designed to meet the charging demands of sensors in a network. The device uses a charging vehicle with a separate charger array to offer power replenishment. A single charging truck with several battery cells was used in this method. Algorithms were used to study the performance of a new wireless rechargeable sensor network model in developed a revised earliest deadline-first scheduling technique to cope with the model. One major advantage of the model is that the charging vehicle in the model does not need to stay on site with the sensor being charged, demonstrating that equipping a charging vehicle with a separable charger array is viable. The simulations show that the improved

earliest deadline-first scheduling technique greatly improves the earliest deadline-first scheduling algorithm with relatively modest overhead in scheduling computation time and a small number of extra chargers. The limitation of this work is the limited number of recollected chargers in the simple backward charger recollecting algorithm and the slightly stricter simulation conditions. a transmitter antenna was built into the wireless charger, while a receiver antenna was fastened to the vehicle's undercarriage. This project used the inductive power transfer technique to transport energy from the transmitter to the receiver across a 25-cm air gap with a high-power transfer efficiency of almost 95%. In this work, the transmitter and receiver's power pads were simulated with the aid of MATLAB and Simulink software. Before the signal was stored in the battery, it was corrected to DC. According to the simulation, the received DC signal at resonance was about 19.56 W after rectification. The work in focused on an Internet of Things-based intelligent wireless charger. This charger was created using a combination of wireless system technologies and mathematical analysis. The experiment that the authors ran included a number of connection points, wireless charging stations, and residential chip gateway locations. The control, transmitter, and receiving circuits of the wireless charger were explored by the authors. The wireless charging system was researched, computed, and created. Although the suggested approach necessitates complex equipment, it is exceedingly safe, effective, and practical for charging electrical products. The outcomes of this work indicate that it can replace wired chargers in small appliances at a rate of 99%. The work offered a low-latency mobile data collection strategy and developed a mathematical model to determine the minimal number of charging cars required, the lifetime of nodes, and adaptive recharge thresholds (Figure 4,5).

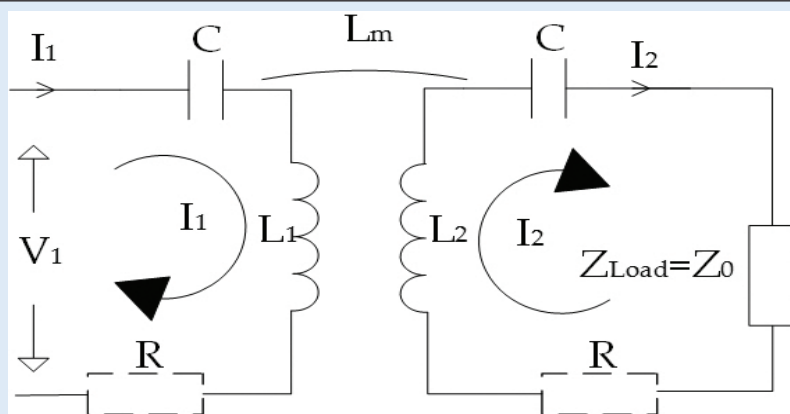
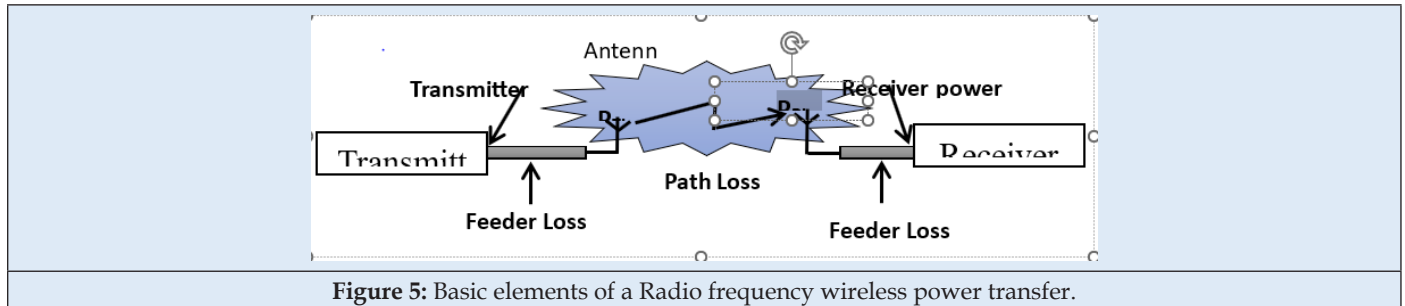

Figure 4: (Agcil, Ozicira and Bekiroglu, 2016).



The greedy method, which optimises recharge profit, and a three-step adaptive algorithm, which systematically captures the recharge capacity and nodes' battery deadline limits while minimising travel expenses, were also proposed by According to the simulations in the adaptive algorithm achieved both great energy efficiency and low latency. To increase the mutual inductance and power transfer efficiency of the WPT system for an electric car, three coil designs with magnetizers were presented in analyzed, and simulated using COMSOL. The simulation results showed that the proposed magnetizer structures enable the wireless charging system to transfer 18-63 kW with an efficiency of 88.7%-92.7% at a transfer distance of 45 cm, and that lengthening the magnetic circuit occupied by a lampshade type magnetizer increased mutual inductance and the system's power transfer efficiency. The work in presented a control method that takes into account both the load's requirements and the limits imposed by other electrical components in the system. devised algorithm prevents any operational disruption caused by passive security controls while also extending the lifetime of other system components and lowering the likelihood of a complete charger breakdown. A Simulink model is used to assess the benefits of implementing the designed controller. To compare the performances of the generic controller and the enhanced version provided in both were implemented. The simulations were run with a maximum primary current limit of 15 amps and a reference charging power of 3.7 kW, which is the maximum power allowed by the installed charger. Under normal circumstances, that is, without coil misalignment, the controller does not need to use the phase shift technique to lower charging power. The coils, however, suffer from a horizontal misalignment of 0.2 m in both dimensions for Gonzalez-Gonzalez, studies, as well as a vertical misalignment that increases the distance between coils by 2 cm. The coils are separated by 0.22 meters. The generic control sets the power to the reference value of 3.7 kW, masking the coil misalignment effects. Despite this, the primary current has exceeded its maximum by 8 amps. This is an evident risk to the charger's exact operation, which will have an impact on its durability. The control system avoids malfunctioning in the entire system and, as a result, increases its durability with these two groups of parameters employed in Gonzalez-Gonzalez, the concept, in particular, adjusts inverter switching in response to coil misalignments. The control design is based on a thorough investigation of the impact of misalignment on a series-series compensation network for an electric vehicle wireless charger. The

primary current is the magnitude of current that is most affected by coil misalignment, according to this investigation. Using two PI controllers, the control system designed can change not only the charging power but also keep the primary current value within a set limit. Simulations in Simulink were used to verify the functionality of this new controller. Based on a mobile charging algorithm, presented a multi-charger cooperative charging technique for the Internet of Things with random node deployment. The multi-charger cooperative charging technique divided charging scheduling for collaboration among several chargers, with charger numbers chosen based on the number of charging requests made by nodes. The uneven clusters were divided into tiers based on the amount of energy left. Then, from the clusters with various levels, the charging sets of various chargers were separated.

This paper offered a conflict avoidance strategy to deal with the potential conflict issue in charger charging sequences. The multi-charger cooperative charging system was tested using MATLAB, and it was compared to other methods. The study, however, did not offer a fresh approach to data gathering or transfer. Furthermore, this work algorithm only considered the absence of network blockages. However, there can be restrictions on the network in the real world. To more effectively respond to massive wireless rechargeable sensor networks, the charging system and the obstacles should be modified. Future research is anticipated to take into account the ideal number of chargers. The work in Truong et al. (2019) describes a series-series topology magnetic coupling wireless power transfer system that may operate at resonance and anti-resonance frequencies brought on by parasitic coil capacitances. It is demonstrated that it is impossible to ignore their impacts on system dynamics. The analytical answer for the power delivered to an electrical load is determined by a mathematical model based on circuit theory. It is suggested to use impedance measurements to obtain coil properties including resistance, inductance, and capacitance. The entire model is then used for additional numerical analyses after being empirically confirmed. The numerical findings demonstrated that in the strong coupling regime, the efficiency of the WPTS under investigation might attain a high level without the need for any optimization methods.

Wireless Power Transfer System: Experimental Research

The work investigated the use of inductive magnetic coupling in low and high frequency bands for WPT as well as its technological

difficulties. In-depth discussion of passive radio frequency identification applications, wireless actuators, structural health monitoring, medical implants, and wireless sensors was done in this study. The major technological obstacles of inductive coupling, including simultaneous data and power transmission, the influence of the surrounding materials, miniaturisation performance, and efficiency regulation restrictions, were also critically analyzed. Although further problems with inductively coupled WPT can potentially be found and resolved in the future by other researchers, this research fell short of addressing all of them. presented a broad-based perspective on the state of the art of wireless power transfer through experiments in the laboratory to determine the inductive coupling extent between two coils. The status and challenges of wireless power transfer were identified. Wireless charging, medical, and military applications were identified. The methods used in this research include a broad classification of wireless power transfer as radiative or non-radiative, as well as a detailed description of each classification. The analysis provided with the experimental data can be used by any designer of wireless power transfer by choosing proper parameters like orientation of coils, numbers of turns, choice of frequency, etc. However, the current implementations of this concept are limited due to the radiative nature of the fields involved in long-distance power transfer. In Moon et al. (2015), a wearable medical wireless charger integrated circuit was created. NiMH batteries were charged using a linear charger by the authors in the integrated circuit is informed of the wireless power charger's connection to a charging pad and the battery's condition via in-band communication. 1.44millimetre squares of silicon are needed for the integrated circuit of the wireless power charger. When the charging current is 26.6 milliamps, it also has a 31.7% efficiency rate. The total efficiency of the charging station is 13.1%, which is a very good performance compared to the quantity of electricity used by the battery. developed an extremely integrated low-power wireless interface with a battery charging unit for small, low-power, and rechargeable battery-controlled medical implant microsystems using conventional CMOS technology. An exclusive packaging platform was made to test the suggested circuits. A prototype chip was made in the standard 0.6-mm 3M-2P CMOS process to test the functionality of the circuit. The integrated circuits have a total surface area of 1.74 mm and a power dissipation of 8.4 mW while generating a load current of 1.5 mA at 4.1 V (or 6.15 mW), resulting in a 73 percent efficiency.

Magnetic Resonance based Wireless Power Transfer System

investigated four potential system topologies for magnetically coupled WPT, taking into account both theoretical analysis and experimental verification. The resonance frequency and power transfer efficiency of each primary and secondary circuit type will be examined in this section. The primary and secondary sides of the topologies are designated as SS, SP, PP, and PS, depending on whether they are parallel (P) or series (S) in nature. It has been demonstrated that the application of a series secondary circuit

is suitable for power transmission to modest loads; however, the parallel secondary circuit is preferable if the load impedance is high. The parallel topology for the primary circuit appears to be an open circuit at resonance, indicating that the inductor will only receive a small amount of current. Because of this, the secondary circuit's power transfer will be insufficient for usage in WPT applications. The study demonstrated that SP topology I is the topology that is best suited for use in WPT. However, in order to maximise load power and transfer efficiency for the longest transfer distance, inductances, capacitances, and the load impedances must be tuned. developed a prototype wireless charging system. The design of the prototype in consists mainly of two parts: a transmitter with a resonator and a receiver with a resonator. The transmitter converts DC voltage to AC and transfers energy to the receiver through mutual induction. The prototype was used to charge mobile phones, and it functioned as proposed with some limitations. The limitations of include a maximum charging distance of about 3 cm, heating of the resonant capacitor, and flux losses due to unguided radiation of EM waves. In Kuo et al. (2015), a 3D resonant wireless charger that enables free rotation of a wearable device around a 360-degree axis while simultaneously charging a mobile phone was demonstrated. A three-dimensional (3D) coil structure was proposed for the transmitter, and a planar coil structure with a size of 29x31 mm² was used for the receiver. The coupling coefficient of the coil pair was extracted from two-port S-parameter measurements on a vector network analyzer. At 6.78 MHz, a prototype charging system with an amplifier and a rectifier is displayed. With a power transmission efficiency of 48 percent, the prototype simultaneously sends 1 W to a wearable gadget and 5 W to a mobile phone.

In Deyle and Reynolds (2008), the authors suggested a low-cost, low-complexity power surface system capable of simultaneously providing wireless power and bidirectional communication to multiple mobile robots from a single surface. This technique allows for the continuous functioning of a swarm of battery-free robots. The first prototype is 60 cm × 60cm power surface that supplies power and bidirectional communication to a group of five test robots, each of which consumes 200mW. Deyle and Reynolds (2008) exhibited a continuous power density of 4.1 mW/cm² for a static load and used capacitor storage and power conditioning circuitry to create substantially higher peak power for dynamic loads. Deyle and Reynolds (2008) also demonstrated simultaneous broadcast communication between the surface and all robots by amplitude modulation of the magnetic field, as well as individual robot-to-surface communication via load modulation. The work in Aswin et al., 2022, designed and implemented a Maximum Power Point Tracking (MPPT)-based wireless battery charger. The Maximum Power Point Tracking and the transmission unit are the two components of the charging system. The integration and operation of the main blocks are aided by the conversion, rectification, and control units. In MATLAB, the MPPT battery charger circuit was implemented. In constant charging mode, the battery reaches steady state voltage and maintains it for

80% of its charging capacity before switching to constant current mode for the final 20%. Because the project is solar-powered, it can be challenging to create enough electricity when necessary. In this work, a rectenna and sensing circuitry were used to create a wireless charging system for mobile devices that uses microwaves and allows users to charge their phones whenever they are outside without carrying a charger with them. In this work, there are many advantages, including a decreased risk of electrical shock due to the lack of a physical connection to the electrical socket, the ability to charge devices anywhere there is a wireless network, increased efficiency due to the non-rectifiability of the power captured by the cell phone, and the elimination of the need to carry a charger at all times. The technique has two drawbacks, including the sensitivity of the human body to microwave radiation and a decreased rate of charging the farther away the phone is from the power source.

Inductive Charging

proposed a wireless charging system for electric vehicle batteries using an Inductive Power Transfer (IPT) system for an E-bike 36 V 10Ah LiFePO₄ battery with a power level that ranges from 100 W to 250 W. Paramesh, analyzed a bi-directional inductive power transfer system and proposed an algorithm for its efficiency optimization. and mathematical analysis was validated through power electronics simulations. From the experimental results of a 79% coupling efficiency for an approximately 100 W level was achieved. Excellent power and high efficiency are the hallmarks of the Low et al., (2009) proposed wireless power system. The transmitter of this device operated on a class E basis by inductive coupling. The transmission coil, receiving coil, and frequency of operation limitations for the proposed system were established. In order to attain high efficiency, the authors also suggested a multichannel architecture for a range of power levels. With IRFP21N60L HEXFET power MOSFETs from international rectifier, which have a 300W and 120V voltage supply capacity, a dual channel test system for class E transmitters was constructed. To automatically generate the values of each component, a MATLAB programme was developed. The system as it is now configured has a power output of 295W at an efficiency of 75.7% for forced air cooling and 69W at an efficiency of 74.2% for convection cooling. In Wang et al (2016), an anti-theft concept was proposed to protect mobile phones while they are being recharged wirelessly using inductive coupling. Electromagnetic field is required to transfer energy between the charger and the mobile phone. In the model proposed the efficiency of energy transfer is low and depends on the distance between the charging and charged coils. In an electronic wristband that can be wirelessly charged and used for medical measurements was conceived and implemented. Four factors, including the physical dimensions, equivalent series resistance (ESR), operating voltage, and capacitance, had a role in the decision to use an electrochemical double-layer capacitor charger for this application. The power supply board of the wristband, which implements a Qi compatible wireless power receiver, an electrochemical double-layer capacitor charger, and

power regulation circuitry, were shown in the block diagram of the entire system. They were connected to a microcontroller board via an interconnection board that also connects the display. The power supply board, the microcontroller board, and the sensor board each house one or more of the chain's crucial parts. A BQ51013B receiver IC, which offers a steady output of 5 V at a current of up to 1 A, was utilized for the construction of the Qi compliant wireless power receiver. The IC is connected to a Würth Elektronik (760308201) Qi-certified receiver coil that was chosen for its high quality and compact design. The receiver coil was positioned beneath the display to reduce the overall size of the wristband gadget and enhance user experience. The device can be charged by aligning the display with a Qi transmitter without removing the wristband, as this suggests that wireless power is transmitted through the display. Sharp's LS013B4DN04 memory LCD display served as the subject of this setup's examination. The bq24640 EDLC charger IC with adjustable constant charge current and maximum voltage was chosen to fast charge the EDLC without overtaxing the Qi receiver. By doing this, the Qi receiver IC's maximum current draw at 5 V is kept below 1 A. The charging voltage and current were set to 1.5 A and 2.7 V, respectively, resulting in a maximum power demand of 4.5 W (considering a charging efficiency of 90%). Future research is anticipated to demonstrate inductive powering for several display technologies (OLED, TFT, LCD), as well as an optimization of the charging time for EDLCs by employing a constant power regulator rather than a constant current charger.

Radio frequency charging and theoretical analysis

The work investigated radio frequency-based wireless charging using commercially available goods. To properly comprehend the technology, a series of experiments were carried out using the Power Cast power charging and harvesting circuit, focusing on the energy received at the charged node, charging time, and charging distance. The report additionally offered a theoretical analysis on how to calculate the quantity of energy received for a specific separation between the transmitter and receiver. Additionally, a description of the specific route loss model that will be utilized based on the crossover distance, such as whether to invoke a Friis model or a two-ray path loss model, is provided. As a result, the amount of energy received was calculated theoretically and compared to the results of the experiments, which revealed a high degree of agreement between the two findings. Additionally, the authors contrasted the charging distance and duration for patch and dipole antennas, and the trial outcomes demonstrated that the latter one produced greater performance. The unsupervised machine learning K-means technique was used to cluster the sensor nodes in a use case related to wireless sensor networks, and the centroid of each K-cluster was selected. In order to power the nodes inside each cluster, an unmanned ground vehicle served as both a cluster head and a wireless charging node. More research will be done in the future to account for the possibility of barriers between the wireless charging station and wireless nodes. Building a charging system and contrasting it with the one utilized in this

study might also be beneficial. The work investigated the most efficient radio frequency (RF) chargers for wireless rechargeable sensor networks' sensor nodes (WRSN). Simulations were used to test the proposed techniques, and they are compared to a related algorithm called Particle Swarm Optimization. The outcome showed that both algorithms had advantages over one another and could be employed in many contexts. New findings from a developing field that integrates wireless power technology for charging applications with radiofrequency (RF) repeater design were described in In order to address the signal blocking issue, a unique passive RF repeater for a wireless charging platform was presented and looked at in this research. When a wireless mobile device is put on a wireless charging platform, the received RF signal may be diminished because the shielding structure for the low-frequency charging signal is not RF friendly. The design and construction of a dual-polarization, free-positioning passive RF signal repeater were successful. The result of this work shows that the RF reception signal intensity can be increased by at least 3.6 dB without significantly reducing energy efficiency during charging. The work in used sensing circuitry and a rectenna for a wireless charging system for mobile devices utilising microwaves, allowing users to charge their phones whenever they are outside without having to carry a charger with them wherever they go. The Sharma, Soni, and Bhargava (2015) system has a number of benefits, including a decrease in the risk of electrical shock due to the lack of a physical connection to the electrical socket, the ability to charge devices anywhere there is a wireless network, increased efficiency due to the non-rectifiability of the power captured by the cell phone, and the elimination of the need to carry a charger at all times.

The human body's susceptibility to microwave radiation and the slower charging rate as the distance between the phone and the power transmitter increases are the system's two drawbacks. In the research on power delivery in implanted devices was the main topic. This was accomplished thanks to tests that were run and that revealed significant increases in power transmission efficiency. According to the results measured, the theoretical model and the simulated outcomes showed a good correlation. When compared to prior-art inductive links of comparable size and operational range, the prototype system displays at least a two-fold boost in efficiency. With an operation distance of 20 mm, external coils with diameters of 64 mm, and implanted coils with diameters of 22 mm, 82% efficiency of power transfer was achieved. When employed over a long distance, the four-coil power transmission system's efficacy only slightly decreases to 73% at a distance of 32 mm. The work described in [20] developed an improved multi-load WPT system. The research established hardware systems for comparison and verification to show that the theoretical analysis is correct. The experiment was designed under the existing conditions of the laboratory. The results of the experiment suggest that by modifying the impedances of the loads accessing the system, the system's overall efficiency can be improved. According to the research, if the loads inside the system adhere to certain requirements, it can

operate at its most efficient level (that does not depend on the impedances of the other loads in the system). The work by proposed an innovative wireless dynamic power transfer technology. There are numerous stationary ground sides in this system, as well as moving vehicle sides. This side was the same as the fixed wireless power transfer system, and the numerous ground-side coils were connected in series. A 3 KW stationary wireless power system was designed, put into practice, and tested as part of According to the theoretical study created, the stationary wireless power transfer system and the proposed system had equal circuitry. However, future work would continue to focus on increasing each ground-side coil's power rating as well as lengthening the mechanical air gap between the buried ground-side coils and the vehicle-side coil.

Summary

The systematic literature review is summarized in the table below in terms of application, methodology or technology, efficiency or limitation, and journal publication year.

Conclusion

Due to its usefulness, wireless power transfer has recently gained popularity. The technology can be used on smaller electronic devices and appliances that charge at power levels between 1 and 300 kilowatts, as well as on portable devices like wearables, which typically charge at power levels below 100 watts. This review study has uncovered the most recent literature on technical design concepts, mathematical analysis, algorithms, simulation, experimental and theoretical knowledge, wireless energy transfer principles, applications, and current issues. A thorough investigation of mobile sensors and wireless charging for applications in mobile devices, wearable medical devices, medical measurements, wireless electric vehicles, and hybrid electric vehicles was carried out. The outcome of a thorough analysis of a few chosen publications in the literature identified areas that needed improvement as well as suggestions for using the project in new contexts.

References

1. Agcal A, Ozcira S, Bekiroglu N (2016) Wireless Power Transfer by Using Magnetically Coupled Resonators. *Wireless Power Transfer-Fundamentals and Technologies*.
2. Álvarez de la Concepción MÁ, Soria Morillo LM, Álvarez García JA, González-Abril L (2017) Mobile activity recognition and fall detection system for elderly people using Ameva algorithm. *Pervasive and Mobile Computing* 34: 3-13.
3. Aswin, P, Thamizh Malar Mathi T, Vikraman R, Chitra S (2022) Design and Implementation of MPPT based Solar Powered Wireless Battery Charger 4(1): 16-27.
4. Banerji A, Datta T, Bandyopadhyay G, Biswas SK, Banerji A, et.al. (2016) Wireless transfer of power: Status and challenges. 2016 International Conference on Intelligent Control Power and Instrumentation.
5. Bravata DM, Smith-Spangler C, Sundaram V, Gienger AL, Lin N, et.al. (2007) Using Pedometers to Increase Physical Activity and Improve Health.

6. Chandrasekar Rao TS, Geetha K (2016) Categories, Standards and Recent Trends in Wireless Power Transfer: A Survey. *Indian Journal of Science and Technology*.
7. Chen TS, Chen JJ, Gao XY, Chen TC (2022) Mobile Charging Strategy for Wireless Rechargeable Sensor Networks. *Sensors*.
8. Chen X, Liu Y, Dong Y, Chen H (2019) Optimal Simulation Study for Wireless Charging Coils With Magnetizers Ieee.
9. Chiauzzi E, Rodart C, Das Mahapatra P (2015) Patient-centered activity monitoring in the self-management of chronic health conditions. *BMC Medicine*.
10. Oyeleke O, Thomas, Nzerem P, Koyunlu G (2019) Design and Construction of a Prototype Wireless Power Transfer Device. *International Journal of Engineering and Manufacturing* 9(2): 16-30.
11. Deyle T, Reynolds M (2008) Surface based wireless power transmission and bidirectional communication for autonomous robot swarms. 2008 IEEE International Conference on Robotics and Automation.
12. Dutta, L, Sunmi FH (2018) Future with Wireless Power Transfer Technology. *Journal of Electrical & Electronic Systems* [online].
13. Dyo V, Mascolo C (2007) A node discovery service for partially mobile sensor networks. *Proceedings of the 2nd international workshop on Middleware for sensor networks – MidSens*.
14. Dyo V, Mascolo C (2008) Efficient Node Discovery in Mobile Wireless Sensor Networks. *Distributed Computing in Sensor Systems* pp. 478-485
15. Fujita T, Yasuda T, Akagi H (2017) A Dynamic Wireless Power Transfer System Applicable to a Stationary System. *IEEE Transactions on Industry Applications* 53(4): 3748-3757.
16. Gonzalez-Gonzalez JM, Trivino-Cabrera A, Aguado J (2017) Control algorithm for wireless EV charger considering operational constraints of electrical components. 2017 11th IEEE International Conference on Compatibility, Power Electronics and Power Engineering (CPE-POWERENG).
17. Han G, Wang H, Guan H, Guizani M (2020) A Mobile Charging Algorithm Based on Multi-charger Cooperation in Internet of Things. *IEEE Internet of Things Journal* 1: 1
18. Helgesen T, Haddara M (2018) Wireless Power Transfer Solutions for 'Things' in the Internet of Things. *Proceedings of the Future Technologies Conference (FTC)* pp. 92-103.
19. Heo JC, Park J, Kim S Ku J, Lee JH (2018) Development and Application of Wireless Power Transmission Systems for Wireless ECG Sensors. *Journal of Sensors*.
20. Huda SMA, Arafat MY and Moh S (2022) Wireless Power Transfer in Wirelessly Powered Sensor Networks: A Review of Recent Progress. *Sensors*.
21. Jang YJ (2018) Survey of the operation and system study on wireless charging electric vehicle systems. *Transportation Research Part C: Emerging Technologies* pp. 844-866.
22. Jawad AM, Nordin R, Gharghan SK, Jawad HM (2017) Opportunities and Challenges for Near-Field Wireless Power Transfer: A Review *Energies*.
23. Jutila M, Strömmer E, Ervasti M, Hillukkala M (2015) Safety services for children: a wearable sensor vest with wireless charging. *Personal and Ubiquitous Computing* pp. 915-927.
24. kawashima T (2015) Electric bus system with rapid charging at every bus stop using renewable energy. *Mechanical Engineering Journal* 2(1).
25. Khalifeh A, Saadeh M, Darabkh KA, Nagaradjane P (2021) Radio Frequency Based Wireless Charging for Unsupervised Clustered WSN: System Implementation and Experimental Evaluation. *Energies* 14(7): 18-29.
26. Kuo RC, Riehl P, Satyamoorthy A, Plumb W (2015) A 3D resonant wireless charger for a wearable device and a mobile phone. [online] *IEEE Xplore*.
27. Li P, Bashirullah R (2007) A Wireless Power Interface for Rechargeable Battery-Operated Medical Implants. *IEEE Transactions on Circuits and Systems II: Express Briefs* 54(10): 912-916.
28. Li Y, Chen Y, Chen CS, Wang Z Zhu Y (2018a) Charging While Moving: Deploying Wireless Chargers for Powering Wearable Devices. *IEEE Transactions on Vehicular Technology* 67(12): 11575-11586.
29. Li Y, Chen Y, Chen CS, Wan Z (2018b) Charging While Moving: Deploying Wireless Chargers for Powering Wearable Devices. *IEEE Transactions on Vehicular Technology* 67(12): 11575-11586.
30. Liu X (2015) Qi Standard Wireless Power Transfer Technology Development Toward Spatial Freedom. *IEEE Circuits and Systems Magazine* 15(2): 32-39.



This work is licensed under Creative Commons Attribution 4.0 License

To Submit Your Article Click Here:

[Submit Article](#)

DOI: [10.32474/MAMS.2023.05.000210](https://doi.org/10.32474/MAMS.2023.05.000210)

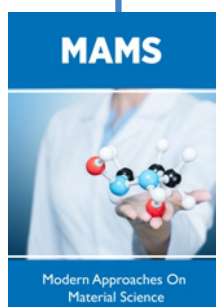

Modern Approaches on Material Science Assets of Publishing with us

- Global archiving of articles
- Immediate, unrestricted online access
- Rigorous Peer Review Process
- Authors Retain Copyrights
- Unique DOI for all articles