

# Gauge Buster Plus

## Operators Manual



**ADMET, Inc.**  
51 Morgan Drive, Norwood, MA 02062  
Tel:(781) 769-0850 Fax:(781) 769-0884  
sales@admet.com www.ADMET.com

## LIMITED WARRANTY

ADMET, Inc. (The Company) warrants that hardware and software/firmware products manufactured by The Company, when properly installed, used, and maintained, will be free from defects in material and workmanship. ADMET, Inc. warrants a) the SOFTWARE/FIRMWARE will perform Substantially in accordance with the accompanying written materials and b) the HARDWARE will be free from defects in materials and workmanship under normal use and service for a period of (1) one year from date of receipt. The Company's obligations under this warranty will be limited to repairing or replacing, at The Company's option, the part or parts of the hardware and software/firmware which prove defective in material and workmanship within one (1) year from the date of delivery, provided the buyer gives The Company prompt notice of any defect or failure and satisfactory proof thereof. Products may be returned to The Company's factory. The Company will deliver replacements for defective products to the Buyer, freight prepaid to the destination provided for in the original order. With respect to any product or part thereof not manufactured by The Company, only the warranty, if any given by the manufacturer thereof, will apply. It is the responsibility of the Buyer to determine the suitability and safety of this product for any particular purpose. The Company disclaims all liability for incidental or consequential damages. In no case will The Company's liability exceed the original purchase price. THE COMPANY MAKES NO OTHER OR FURTHER WARRANTY, EXPRESS OR IMPLIED, INCLUDING ANY WARRANTY OF FITNESS FOR A PARTICULAR PURPOSE OR WARRANTY OF MERCHANTABILITY.

## COPYRIGHT NOTICE

The contents of this manual copyright (c) 1999-2007. All rights reserved. Nothing in this manual may be reproduced in any manner, either wholly or in part for any purpose whatsoever without written permission from ADMET, Inc.

## GAUGE BUSTER PLUS LICENSE AGREEMENT

This is a legal agreement between you, the end user, and ADMET, Inc (The Company). By using **Gauge Buster Plus** you are agreeing to be bound by the terms of this agreement.

**1.0 License Grant.** The Company hereby grants the end user a personal, nontransferable and non exclusive license to use one copy of the software/firmware and related documentation on a single indicating system.

**2.0 Intellectual Property Rights.** The Company is the sole owner of all right, title and interest to the **Gauge Buster Plus** and all copyrights, trademarks, and trade secrets therein. The Company is protected by United States copyright laws and international treaty provisions. Therefore, the end user must treat the software/firmware like any other copyrighted material and may not copy the written materials accompanying the **Gauge Buster Plus**.

**3.0 Restrictions.** This Agreement and the Licensed Software/Firmware may not be assigned, Sub-licensed or otherwise transferred by the Customer. The end user must not reverse engineer, decompile, or disassemble the Licensed Software/Firmware or attempt to do so. The Licensed Software/Firmware may not be modified without the written consent of The Company.

**4.0 Termination.** The Company may terminate the license contained in this Agreement by written notice upon any breach of any term by the end user. Upon termination, the end user shall immediately return the **Gauge Buster Plus** to the factory. Section 2.0 of this Agreement shall survive termination of this Agreement.

**5.0 Purchase by Governmental Agencies.** If the end user is a federal, state or local governmental agency or unit, then as a matter of contract, the end user will accord The Company and the Licensed Program the same rights The Company would have had under the Copyright Act of 1976, as amended.

**6.0 Governing Law.** This Agreement shall be governed by and construed in accordance with the laws of the Commonwealth of Massachusetts.

# Table of Contents

<b>FOREWARD</b> .....	<b>3</b>
<b>1.0 INTRODUCTION</b> .....	<b>4</b>
1.1 Gauge Buster Plus Options .....	4
1.2 Printed or Transmitted Reports .....	4
<b>2.0 THE KEYS</b> .....	<b>5</b>
2.1 The <ZERO/0> Key .....	5
2.2 The <STORE> Key .....	5
2.3 The <ENTER> Key .....	5
2.4 The <ESC> Key .....	5
2.5 The <UP & DOWN ARROW> Keys .....	5
2.6 The <NUMBER> Keys .....	5
<b>3.0 THE MENUS</b> .....	<b>7</b>
3.1 The SETUP Menu .....	7
3.2 The PRINT Menu .....	8
3.3 The UTILS Menu .....	8
3.4 The ID# Menu .....	8
<b>4.0 OPERATION</b> .....	<b>9</b>
4.1 How to Setup a Test .....	9
4.2 How to Perform a Test and Save Results .....	9
4.2.1 The Indicator Status .....	10
4.3 Printing Test Reports to a Serial Printer .....	10
4.4 How to Download Stored Test Results to a Remote PC .....	10
4.5 Options .....	11
<b>5.0 CALIBRATION</b> .....	<b>12</b>
5.1 How to Calibrate Analog Transducers .....	12
5.2 What Occurs During Calibration .....	13
<b>6.0 TROUBLESHOOTING</b> .....	<b>14</b>
<b>7.0 ELECTRICAL/MECHANICAL DATA</b> .....	<b>17</b>
7.1 User Connections .....	17
7.2 Serial-I/O Port .....	18
7.3 Power (DC) Input .....	18
7.4 Mounting Dimensions .....	19
7.5 Password .....	20
<b>Index</b> .....	<b>21</b>

# FOREWARD

**Gauge Buster Plus** has been designed and constructed with great care in every phase of assembly. In order to insure reliability, both the mechanical and electrical components have been built with the best available materials. Nevertheless, it has been proven that a thorough understanding of the machine, together with proper attention, will pay big dividends. The sections of this manual provide description and instruction on the operation and maintenance of the mechanical, electrical and software components.

You as a customer are our most valued asset. We take pride in our systems and are proud that you have become an owner. We welcome your comments about our products and wish that you express them. It is the only way that we can continue to build the best available test systems to satisfy your needs. Thank-you for your support.

## HOW TO USE THIS MANUAL

This manual is intended to educate the customer on the capabilities, operation and maintenance of the **Gauge Buster Plus**. In addition, it is to be used as a supplement for any information supplied by the load frame manufacturer. Maintenance procedures specified by the load frame manufacturer should be followed unless specifically noted herein. Read this manual and become familiar with the operation of your test machine prior to operating the **Gauge Buster Plus**.

## TECHNICAL SUPPORT

If a problem should occur with your testing machine:

- 1 Consult troubleshooting section on-line and in this manual
- 2 Check that all external inputs are properly connected.
- 3 Call the supplier/manufacturer of your test machine.
- 4 Call ADMET's technical support at (781) 769-0850 (9AM to 5PM EST).

# 1.0 INTRODUCTION

**Gauge Buster Plus** is a low cost indicator designed to replace dial gauges on materials testing machines. Features include an Auto-Test-Reset mode for hands free operation, bar graph load rate display, permanent storage of test data and easy transfer of results into data base programs. It's accuracy, which exceeds ASTM E4, ease-of-use and ruggedness results in a system of unrivaled price/performance.

**Gauge Buster Plus** is ideal for:

- Beam Bend Testing
  - Concrete Cylinder Testing
  - Cement Cube Testing
  - Force Calibration
  - Remote On-Site Testing
  - Quality Control
  - Product Evaluation
  - Proof Testing
- 
- Display Live Load, Peak Load and Peak Stress numerically.
  - Indicate Load Rate with a bar graph. The rate pointer moves between its limits. Decreasing the rate moves the pointer left. Increasing the rate moves the pointer right.
  - Adjust the upper and lower rate limits depending on the testing requirements.Ex: ASTM C39 35 +/- 7 psi/sec.
  - Select engineering units of Lb, N, KN and Kg. Stress in PSI, Mpa, Kpa and ksc. Length in inches, mm, or cm.
  - Define and detect the end of test with the Sample Break Detector.
  - Auto-Test-Reset which automatically enables the indicator for the start of the next test without requiring operator interaction.
  - Store up to 400 test results to permanent memory. Results include Date, Time, Specimen ID#, Peak Load plus a statistical summary of Peak Load. Report options include Job#, Specimen Age, and Weight.
  - Activate Auto-Store to automatically store the results of each test.
  - Activate Auto-Transmit to automatically print the results of each test out the serial communications port.
  - Transmit results to a printer or remote computer through the serial communications port.
  - Store up to four load cell calibrations for multiple load cell systems. The load calibration algorithm allows up to 5 calibration points per cell with piecewise linear fit between points. Accuracy exceeds ASTM E4 Standards and in general is greater than 0.5% from 1% of full scale to full scale.
  - Digital output activates at sample break or machine overload.

## 1.1 Gauge Buster Plus Options

- WinCom Windows based serial communications software to import data into spreadsheet and database programs.
- Bar Code Reader input to scan specimen number into the Gauge Buster.
- S-Trak, ADMET's database and report generation program for concrete cylinders.
- Battery Pack for portable applications.
- Shunt Calibration.
- Serial RS-232 Printer.
- Pressure Transducers - 1,000 2,500 5,000 10,000 psi.

## 1.2 Printed or Transmitted Reports

- **Test Results Report.** Test reports with up to 400 results stored to permanent memory is standard. Each test report consists of: date, time, specimen ID#, peak load plus a statistical summary of load.
- **Load Calibration Report.** A load calibration report can be produced for each load cell calibration table which has been accessed. The report consists of the full scale and resolution values for each calibration table in addition to the measured and corresponding load value for each calibration point.

# 2.0 THE KEYS

## 2.1 The <ZERO/0> Key

The ZERO key performs the following functions.

- Defines a new zero load.
- Places the Indicator Test Status in Ready Mode.
- Clears out the previous test results from the test buffer and initializes the indicator for the next test. **Make sure the previous test was stored prior to pressing ZERO or it will be lost.**
- Enters the number zero.

## 2.2 The <STORE> Key

The STORE key writes the current test result which consists of peak load, date, time and specimen ID# to permanent memory then increments the specimen ID#. All results stored to memory can be printed or download to a remote computer.

## 2.3 The <ENTER> Key

The ENTER key performs the following functions.

- Accepts/assigns the value in a data entry field to that field.
- Turns ON/OFF a menu option.

## 2.4 The <ESC> Key

The ESC key performs the following functions.

- Returns to the Live Indicating Screen from any menu.
- Clears a data entry mistake by restoring the original number in a data entry field.

## 2.5 The <UP & DOWN ARROW> Keys

The ARROW keys allow the operator to scroll through menu items.

## 2.6 The <NUMBER> Keys

The NUMBER keys are used to select a menu option from within a menu or input a numerical value in a data entry field.

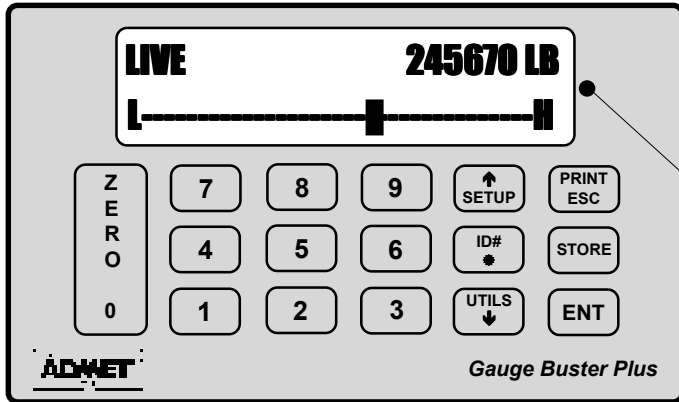

*Display while specimen under test: Live Load and Load Rate Pointer shown between High and Low Rate Limits.*

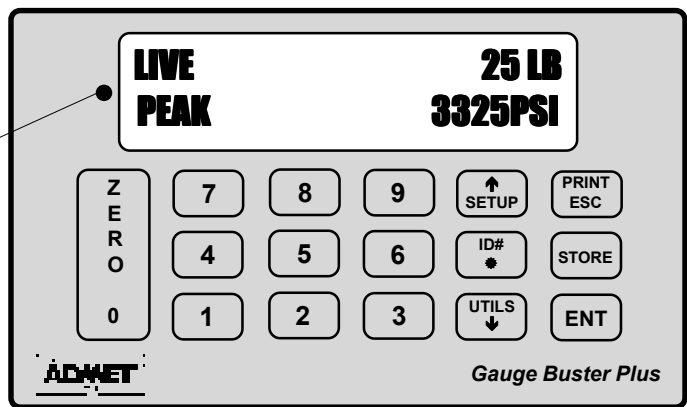

*Display after specimen break detected: Live Load is displayed on the first line and Peak Load and Peak Stress toggle automatically on the second line.*

Figure 2.1 - **Gauge Buster Plus** Keypad and Screen Display.

# 3.0 THE MENUS

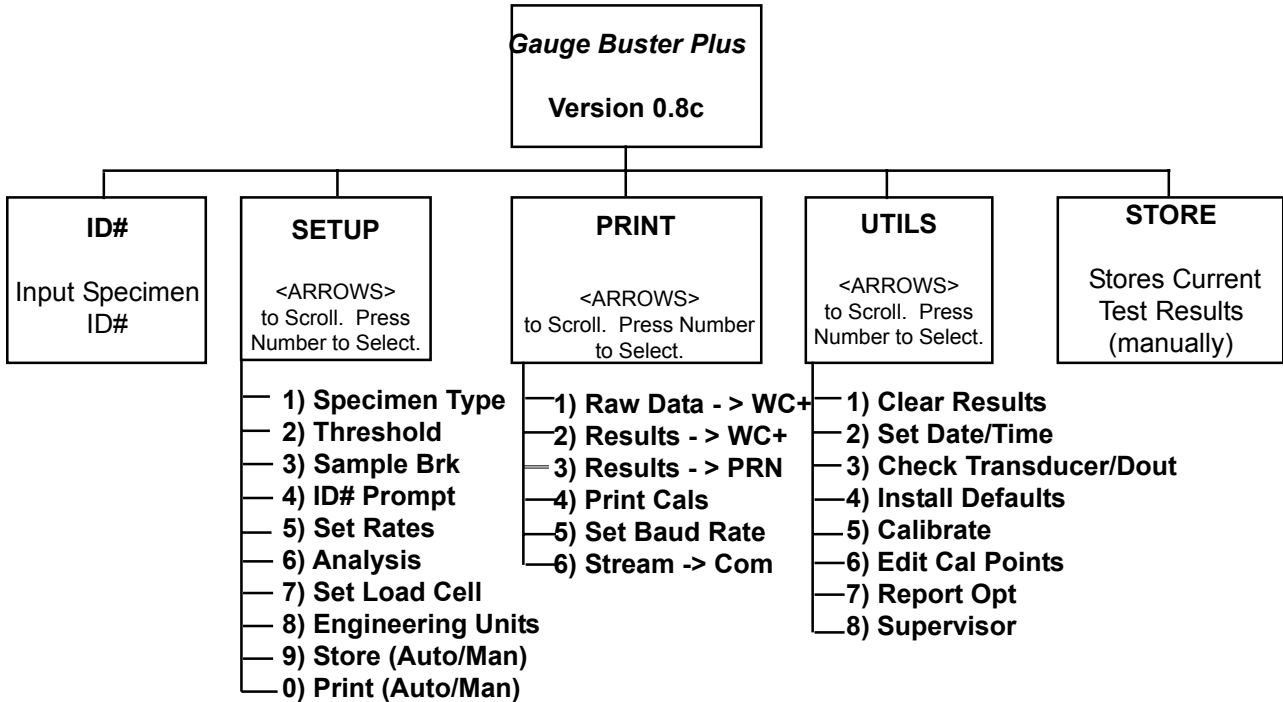

Figure 3.1 - *Gauge Buster Plus* Menus.

## 3.1 The SETUP Menu

Press the <SETUP> key from the Indicating Screen to enter the SETUP Menu. Use the <ARROW> keys to scroll through the menu items. Use the <NUMBER> keys to select the menu item. The following functions are provided in the SETUP Menu.

- 1) **Specimen Type.** Select the specimen type for the sample to be tested. After selecting the type of specimen, the appropriate dimensions are requested.
- 2) **Threshold.** Set the start test threshold in load units. The start of a new test is marked by when the load goes above the threshold value. *Gauge Buster Plus* employs a 2 line by 16 character display. When a test is not in progress the lower line of the display will show the peak load from the previous test. When the load exceeds threshold, the lower line of the display will change over to rate indication.
- 3) **Sample Brk.** Sample Break is defined as a percentage of peak load and is used to define the end of a test. If Sample Break = 10 percent and Peak Load = 100,000 Lb, then the test will terminate when the load drops below 10,000 Lb.
- 4) **ID# Prompt OFF/ON.** Select **ON** for display to prompt for Specimen ID# when storing the test results.
- 5) **Set Rates.** Defines the lower and upper limits for the rate pointer. The lower limit is marked as an "L" on the rate display line and the upper limit is marked as an "H" on the rate display line during a test.
- 6) **Analysis.** Available analysis: Yld Halt: yield by halt of force; Avg Rate: average load rate. Toggle analysis OFF/ON
- 7) **Set Load Cell.** *Gauge Buster Plus* will store up to four load cell calibrations in permanent memory for multiple load cell applications. Set Load Cell is used to select which load cell calibration is used for a given test (L0-3). The active load cell is displayed in the upper left hand corner of the Live Indicating Screen.  
Password required to Set Load Cell: 157
- 8) **Engineering Units.** Used to select between load units of Lb, N, KN, and Kg, Stress units of PSI, Mpa, Kpa and ksc and rate units on a per second or per minute basis.
- 9) **Store.** If **Store** is set to AUTO, the results are automatically written to the results buffer and the specimen ID# is incremented when sample break is detected. If **Store** is set to MAN, it is necessary to press the <STORE> at the end of test to save the test results to memory and increment the specimen ID#.



0) **Print.** If **Print** is set to AUTO, then the results are automatically sent to the RS232 serial port when sample break is detected.

The **Gauge Buster Plus** will automatically print column headings at power up or when exiting the SETUP Menu. If **Print** is set to MAN, pressing the <PRINT> key, will print all stored test results.

## 3.2 The PRINT Menu

Press the <PRINT> key while in the Indicating Screen to enter the PRINT Menu. Use the <ARROW> keys to toggle through the menu. Use the <NUMBER> keys to select the menu item. The following functions are provided in the PRINT Menu.

- 1) **Raw Data -> WC+.** Transmit the test results stored in the results buffer in text format (not delimited).
- 2) **Results -> WC+.** Transmit the test results stored in the results buffer to a comma delimited text format (CSV file format). A comma delimited text format allows the file to be properly imported into spreadsheet and database programs. WinCom is a program offered by ADMET to capture and save test results on a remote PC. WinCom can also be configured to automatically import the results into a spreadsheet or database program.
- 3) **Results -> Prn.** Transmit the test results stored in the results buffer in text format (not delimited) to a serial printer.
- 4) **Print Cals.** Print all load cell calibrations.
- 5) **Set Baud Rate.**
- 6) **Stream -> Com.** Toggle to **ON** to stream live out RS232 during test.

NOTE: The data output port in the **Gauge Buster Plus** is an RS232 serial port which can be connected to a serial printer or remote computer. The serial protocol is 9600 baud, 8 data bits, 1 stop bit and no parity. See Section 7.1 for connections to the Serial-I/O port.

## 3.3 The UTILS Menu

Press the <UTILS> key from the Indicating Screen to enter the UTILS Menu. Use the <ARROW> keys to scroll through the menu. Press the <NUMBER> keys to select the menu item. The following items are found in the UTILS Menu.

- 1) **Clear Results.** Erase all test results stored in the results buffer. Make sure you have printed the data before erasing memory.
- 2) **Set Date and Time.** **Gauge Buster Plus** is Y2K compliant.
- 3) **Ck Trans-DOUT.** This function displays the transducer readings in A/D counts and also allows the operator to turn the overrange/sample break digital output ON and OFF. Possible A/D values are between - 2,200,000,000 and +2,200,000,000.
- 4) **Install Defaults.** Used to put all setup parameters in a known default state. **Installing defaults DOES NOT effect any of the calibration information.**
- 5) **Calibrate.** Calibrate a load cell according to ASTM E4 standards. See Section 5.0 for calibration procedures.
- 6) **Edit Calibration Points.** This function allows the calibrator to modify the load value for a given calibration point.  
NOTE: The calibrator can also edit A/D counts in the calibration. Select **Install Def** from the **Utility** menu. The
- 7) screen will read **1)Install; ESC)Exit.** Press the "9" key to get into the edit A/D count screens.  
**Report Options.** This function allows the user to select which optional report fields; Job#, Specimen Age, and Weight, to activate. If one or more of these optional fields are turned ON, at the press of the ID# key, the Specimen# prompt appears followed by prompts for each of the active Report Options.

## 3.4 The ID# Menu

Press the <ID#> key from the Indicating Screen to input the Specimen ID#. The Specimen ID# can be 8 digits long. Input the Specimen ID# and press <ENTER> to accept the ID#. Note: The Specimen ID# will be automatically incremented after the current test result has been printed or stored. If Report Options in the SETUP menu are turned ON, prompts for JOB#, Spec Age, and Weight will follow the Specimen# prompt.

# 4.0 OPERATION

## 4.1 How to Setup a Test

Section 4.1 describes how to setup for a test. Section 4.2 describes how to perform a test and store the results to memory. Section 4.3 describes how to generate test reports. Section 4.4 describes how to download the stored test results to a remote PC.

**Step 1:** Press <SETUP> from the Indicating Screen. From the SETUP Menu select the following and enter values for each.

**Specimen Type.** Specimen type to be tested, Cylinder, Cube, Beam Ctr, Beam 3rd, Round or Area.

**Threshold.** Enter a load value which when exceeded will signal the start of a new test.

**Sample Break.** Enter a number as a percentage of peak load which will define the end of test.

### Set Rates

**Rate-Lo.** Enter the lower rate limit, marked as "L" in the rate display.

**Rate-Hi.** Enter the upper rate limit, marked as "H" in the rate display.

**NOTE:** If Specimen Type set to Cylinder, then lo and hi rate values automatically set to appropriate value as specified by ASTM C39.

**Load Cell.** Select the load cell number if necessary.

**Engineering Units.** Set load units to Lb, N, KN or Kg. Set rate units to per second or per minute.

**Store.** AUTO/MANUAL

**Print.** AUTO/MANUAL

See Section 3.1 for more information.

**Step 2:** Press <UTILS> from the Indicating Screen. Clear results from memory. Note: If the stored results are important, print before clearing. See Section 3.3 for more information.

**Step 3:** Press the <ID#> from the Indicating Screen. Input the specimen ID#. The specimen ID# will automatically increment after the current test is stored. If Report Options have been turned ON, additional prompts will follow.

## 4.2 How to Perform a Test and Save Results

If the steps in Section 4.1 were followed, you are now ready to perform a test. The current test settings are saved in permanent memory and will not change unless they are modified by the operator.

**Step 1:** Insert the specimen in the machine and move the crosshead to the desired starting position. If using a hydraulic machine, float the piston by moving off its stop.

**Step 2:** Press the <ZERO> key to tare any residual load from the readout.

**Step 3:** Begin loading the specimen. Once the load exceeds the start test threshold value, the lower display line will change to the rate pointer and the Sample Break detector is armed.

**Step 4:** Once sample break is detected the test is complete and the lower display line will show peak load. If Auto Store or Auto Print are turned ON, the results will either be saved to memory or printed automatically. If Auto Store is turned OFF, press <STORE> to save the current test results. Note: If you do not press <STORE> before pressing <ZERO> or the start of a new test, the results will be lost.

To continue running tests, repeat Steps 1, 3, 4.

**NOTE: The Gauge Buster Plus** is designed to operate in a "hands free" mode. This means that once it has been setup and properly zeroed, the operator should not have to touch the keypad. If a test result is stored, the specimen ID# will automatically increment.

### 4.2.1 The Indicator Status

READY and TESTING are the two possible Indicator Modes. Below is a picture of the Live Indicating Screen during each mode.

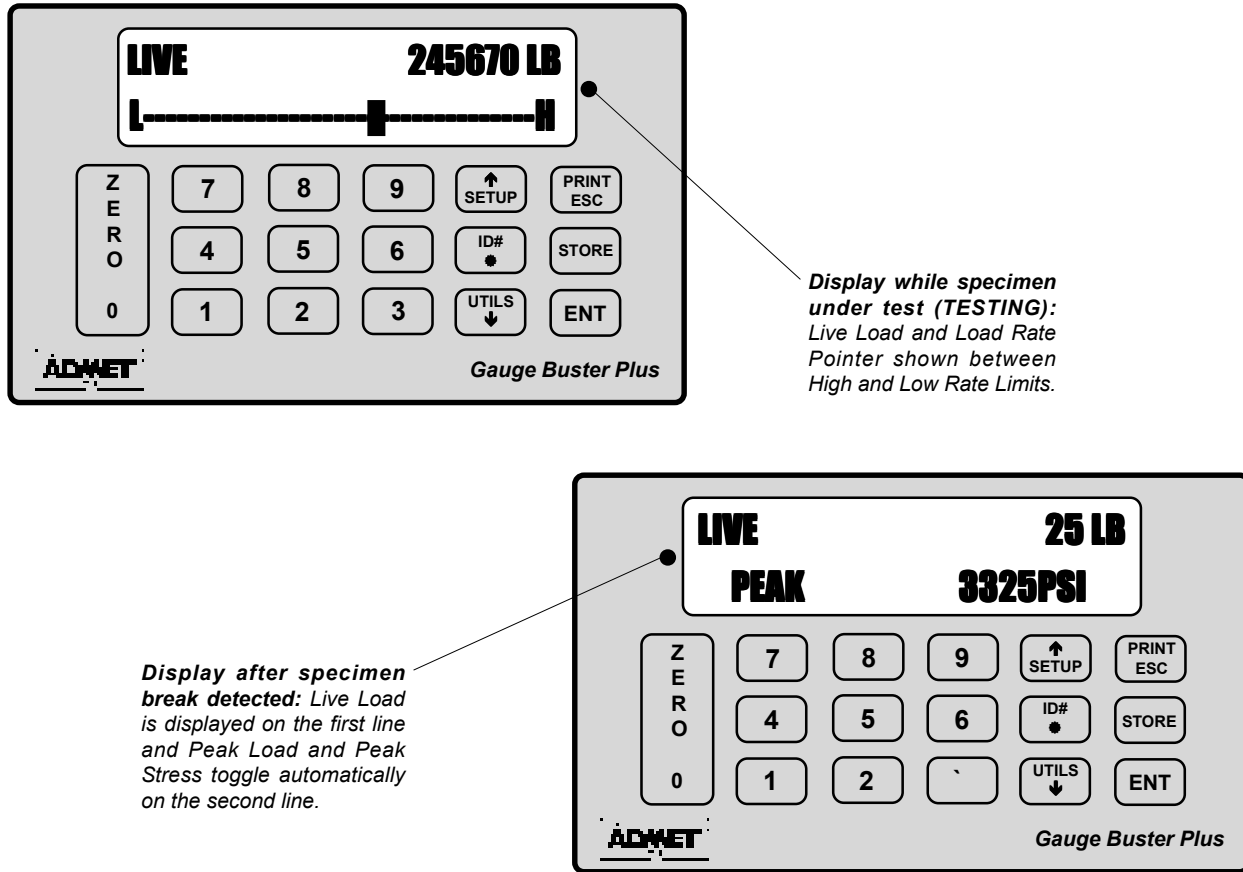

Figure 4.2.1 - The Live Indicating Screen Modes.

### 4.3 Printing Test Reports to a Serial Printer

If the steps in Section 4.2 were followed, a test report containing all of the results stored to memory can be obtained.

**Step 1:** Press <PRINT> from the Indicating Screen.

**Step 2:** Turn on your printer and Press <1> Results to Printer to print all stored tests.

### 4.4 How to Download Stored Test Results to a Remote PC

A data transfer cable and WinCom program diskette manufactured by ADMET is required to download test results to a remote PC. Refer to the WinCom program manual for downloading test results to a computer.

## 4.5 Options

- *BAR CODE READER (BarCode input)* allows a RS232 serial Bar Code Reader to be used to scan barcode data into the Specimen # field of the test results. ADMET can supply the Bar Code Reader, Bar Code Tags and Results Database Software if desired.

The options listed below are available with Gauge Buster Plus. Each option will not work unless it has been purchased.

- *CHECK CALIBRATION (CKCAL)* only works with transducers that employ a wheatstone bridge. It functions by shunting a known resistance across two legs of the bridge to generate a constant output. That output is used to verify that the electronics are functioning properly. The procedure for CHECK CALIBRATION is as follows:
  - 1) Unload the machine and press <ZERO>.
  - 2) Wait a few seconds, then press <ENT>. A non-zero load reading should be displayed for 3 seconds.
  - 3) Note the load reading and compare it to previous calibration checks. Contact your service representative if there is a large difference between readings.

# 5.0 CALIBRATION

Refer to Section 7.1 for details on transducer connections.

## 5.1 How to Calibrate Analog Transducers

**Step 1:** Turn on the system and allow it to run for 10 minutes before calibrating.

**Step 2:** Select the Engineering Units for calibration from the SETUP Menu. See Section 3.1 for more information.

**Step 3:** Select <5> Calibrate from the UTILS Menu.

**Step 4:** Enter the password. Call your equipment manufacturer if you have lost the password.

**Step 5:** Enter the load cell number. Use zero if your system has only one load cell.

**Step 6:** Input the full scale range or the capacity of the machine. The range should be input in the currently active engineering units.

**Step 7:** Input the resolution or minimum load increment.

**Step 8:** Press <1> Calibrate to enter the measure mode or <ESC> to exit. **If you decide to exit the Calibration Menu at this time the values entered for Full Scale and Resolution will be saved.**

### Required Information Before Continuing Calibration

The program will enter the measurement mode if <1> is pressed in Step 8. During this mode, the technician can take up to five calibration point readings (a minimum of 2 points is required). **The first calibration point must be at zero load.** It may be beneficial to take a few more calibration readings in areas of greatest inaccuracy. The number next to "PT" on the display will indicate how many calibration readings have been taken. As the calibration points are entered, write down the corresponding load value. After all five calibration points have been taken, or the <STORE> key is pressed when using less than five points, the **Gauge Buster Plus** automatically switches to engineering input mode. Input the load value corresponding to each calibration point reading stored. The calibration points are stored sequentially. The first point is zero followed by the second, third and so forth. Once an engineering unit value has been entered for each calibration point stored, the unit will automatically save the calibration.

**Step 9:** Unload the machine or place the transducer at its zero point. If calibrating a hydraulic machine, float the piston before taking any readings. Press <ENTER> to take the zero reading. The left side of the display will indicate PT1 has been read.

**Step 10:** Load the machine to a desired load and press <ENTER> to set a calibration point (voltage measurement). The voltage value is NOT displayed but it has been saved to non-volatile memory. Write down the corresponding engineering unit value for each calibration point. Repeat this step until all readings are taken.

**Step 11:** Press <STORE> to exit the measurement mode if fewer than five calibration points are used. The program will automatically proceed from Step 10 to Step 12 after the fifth reading.

**Step 12:** Input the corresponding engineering unit value for each measurement point. After all values have been entered, the program will automatically generate the corresponding scale factors and store them to permanent memory.

**DONE! READY TO VERIFY CALIBRATION**

**Step 13:** To verify the calibration, exit out to the Indicating Screen and apply specific loads to the machine and compare the reading on the indicator with the standard.

**Step 14:** If you choose to adjust one or some of the calibration points, use the Edit Calibration function from the UTILS menu. This function will allow you to edit load values for one, some or all calibration points without forcing you to repeat Steps 2-12.

## **5.2 What Occurs During Calibration**

The calibration procedure allows up to five calibration points to be entered. Each successive pair of points is connected by a straight line and the slope of each line is the calibration scale factor used for that region. This results in a piecewise linear function which maximizes accuracy.

# 6.0 TROUBLESHOOTING

Gauge Buster PLUS Troubleshooting		
Problem Description	Possible Causes	Action
<p>Not holding peak load</p> <p>OR</p> <p>Not tracking load while machine actually loading and breaking sample.</p> <p>OR</p> <p>Rate Bar not being displayed.</p>	<p>Threshold AND/OR Sample Break Settings</p>	<p><b>NOTE:</b> Gauge Buster PLUS Digital goes into TESTING MODE when the actual load exceeds the programmed load threshold value. When the Gauge Buster PLUS Digital is in the TESTING MODE, live load is displayed on upper right and load rate bar or load rate is displayed in the bottom of the display. If you do not see load rate bar or load rate in the bottom display then you are NOT in testing mode and need to look at your Threshold value and your Sample Break value.</p> <p>Ensure that Threshold (SETUP menu) is set to value that is appropriate for test. Threshold is the point where the digital begins data logging and is armed for sample break. If threshold is too low then load drop in early part of test could trigger the Gauge Buster PLUS to detect premature specimen break (end of test) and stop logging data. For example if Threshold is set to 10lbs (much too low) and sample break percentage is set to 50% and the load climbed to 20lbs and then dropped to 10lbs the Gauge Buster PLUS would detect sample break, stop logging data and report a peak load of 20lbs.</p> <p>Ensure that Sample Break (SETUP, End of Test menu) is set appropriately. Sample Break is defined as a percentage of peak load and is used to define the end of a test. If Sample Break = 10 percent and Peak Load = 100,000 Lb, then the test will terminate when the load drops below 10,000 Lb. If sample break is set to 0 then Gauge Buster PLUS does not register end of test and if sample break percentage is set very high then end of test can be triggered early.</p>
	<p>Applying Load too quickly after taring Gauge Buster PLUS</p>	<p><b>NOTE:</b> The Gauge Buster PLUS is designed for hands-free operation. You should only need to zero the digital once. It is not necessary and NOT recommended to zero the digital prior to each test. Doing so can prevent digital from going into Testing Mode and not record peak load. If you do not see the rate bar or load rate display on bottom line of display it means that digital is not going into testing mode.</p> <p>Ensure that you are that you are waiting at least 3 seconds after zeroing digital before applying load to your break machine.</p>
<p>Cannot Transmit data to WinCom/WinCom PLUS.</p>	<p>WinCom is not open</p>	<p>Ensure that WinCom/WinCom PLUS is running and ready to receive data.</p>
	<p>Not initiating transfer from Print menu in Gauge Buster PLUS.</p>	<p>Ensure that you are selecting the proper menu item from the Gauge Buster PLUS <b>Print</b> menu. Print menu items for transfer to WinCom/WinCom PLUS end with <b>-&gt; WC+</b></p>
	<p>Serial Cable between Gauge Buster PLUS and Computer is not connected</p>	<p>Ensure that null modem cable is properly connected between Gauge Buster PLUS and computer running WinCom/WinCom PLUS software</p>
	<p>Serial Cable incorrect.</p>	<p>Ensure that null modem cable is properly connected between Gauge Buster PLUS and computer running WinCom/WinCom PLUS software</p>
	<p>Proper com port is not selected in WinCom</p>	<p>Select correct com port from <b>Utilities-&gt; Comm</b> menu in WinCom/WinCom PLUS software.</p>
	<p>Baud Rate settings in Gauge Buster PLUS and WinCom do not match</p>	<p>Ensure that Baud Rate selection in Gauge Buster PLUS (Print menu) matches that set in WinCom/WinCom PLUS software; <b>Utilities-&gt; Comm</b> menu.</p>

<b>Gauge Buster PLUS Troubleshooting</b>		
<b>Problem Description</b>	<b>Possible Causes</b>	<b>Action</b>
Cannot automatically transmit XY Data to RS232 at the end of test	Not available on the Gauge Buster PLUS	
Cannot automatically transmit test result to RS232 at the end of test.	Action not selected on Gauge Buster PLUS	Ensure that <b>Print</b> menu item in <b>SETUP</b> menu is set to <b>AUTO</b> .
	Serial Cable between Gauge Buster PLUS and Computer is not connected	Ensure that null modem cable is properly connected between Gauge Buster PLUS and computer running WinCom/WinCom PLUS software
	Baud Rate setting on receiving com port.	Ensure that baud rate on receiving port is set to 9600
Cannot stream live XY data to RS232. (Version 0.7t and earlier)	Action not selected on Gauge Buster	Ensure that <b>Stream-&gt; COM</b> menu item in <b>Print</b> menu is set to <b>ON</b> .
	Baud Rate Setting on receiving port.	Ensure that baud rate on receiving port is set to 115,200.
	Serial Cable between Gauge Buster and Computer is not connected	Ensure that null modem cable is properly connected between Gauge Buster and computer running WinCom/WinCom PLUS software
Cannot stream live XY data to RS232. (Version 0.8a and later)	WinCom LIVE software is not open	Ensure that WinCom LIVE software is open and ready to receive data.
	Action not selected on Gauge Buster	Ensure that <b>Stream-&gt; COM</b> menu item in <b>Print</b> menu is set to <b>ON</b> .
	Serial Cable between Gauge Buster and Computer is not connected	Ensure that null modem cable is properly connected between Gauge Buster and computer running WinCom/WinCom PLUS software



<b>Gauge Buster PLUS Troubleshooting</b>		
<b>Problem Description</b>	<b>Possible Causes</b>	<b>Action</b>
Load reading wrong	Calibration	Ensure that correct load calibration is selected. The Active Calibration # is displayed in the upper left of the live screen. The Gauge Buster PLUS can store up to four load cell calibrations.
	Analog/Digital Electronics	Contact ADMET technical support.
	Excitation Voltage bad.	Contact ADMET technical support.
	Load Transducer Cable	Replace/fix transducer cable NOTE: refer to See Electrical/Mechanical Data section of this manual for cable wiring information.
	Load Transducer	Replace load transducer
Stress reading wrong	Specimen Information	Stress is a calculated value. It is equal to the load divided by the programmed specimen cross-sectional area.  Ensure that <b>Specimen Type</b> and specimen dimension information is correct in the <b>SETUP</b> menu.
Load reading unstable	Calibration	Ensure that there is valid calibration in selected load channel. Valid calibration means calibration with at least two points, appropriate full scale and resolution settings, and good A/D count span between the points in the calibration.
	Analog/Digital Electronics	Contact ADMET technical support.
	Excitation Voltage bad.	Contact ADMET technical support.
	Load Transducer Cable	Ensure that cable gain strap is properly wired for transducer being used. Replace/fix transducer cable  NOTE: refer to See Electrical/Mechanical Data section of this manual for cable wiring information.

# 7.0 ELECTRICAL/MECHANICAL DATA

## 7.1 User Connections

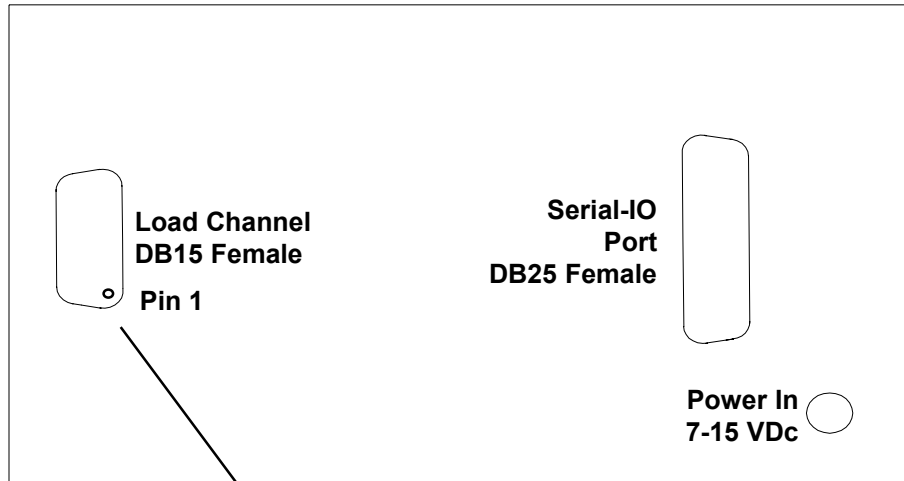

**Please note the location of Pin 1**

Figure 7.1.1 - *Gauge Buster Plus* Rear Connection Panel.

### Load Channel Connections

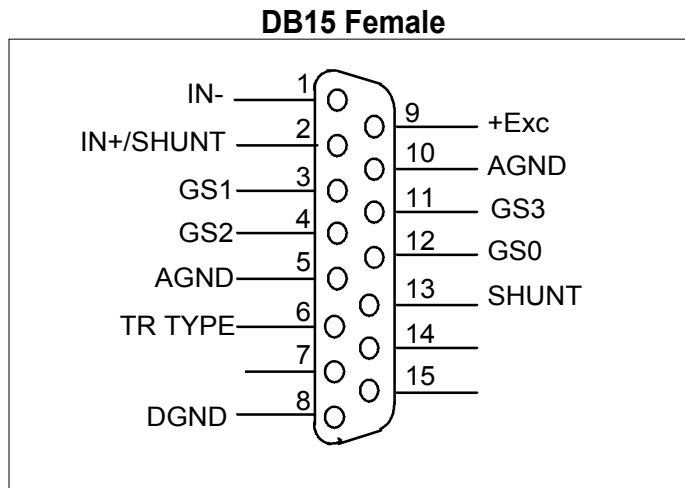

#### Analog-Load Input

#### Analog Excitation:

pins 9 & 10 (+Exc & AGND)  
5 Vdc

**Analog Inputs:** pins 1 & 2 (+/- IN)

#### Analog Input Range:

up to 2.5 mv/v Tie pin 3 to pin 12  
 up to 4.5 mv/v Tie pin 4 to pin 12  
 +/- 5 V No Connection  
 User definable Tie <25 ppm/C resistor  
 between pin 11 & pin 12.  
 Gain = 1 + 50000/Rg.

Connect all shields to chassis.

**Transducer Identification** (Contact Factory)

Figure 7.1.2 - Analog Transducer Pin Designation.

### DB25 Female

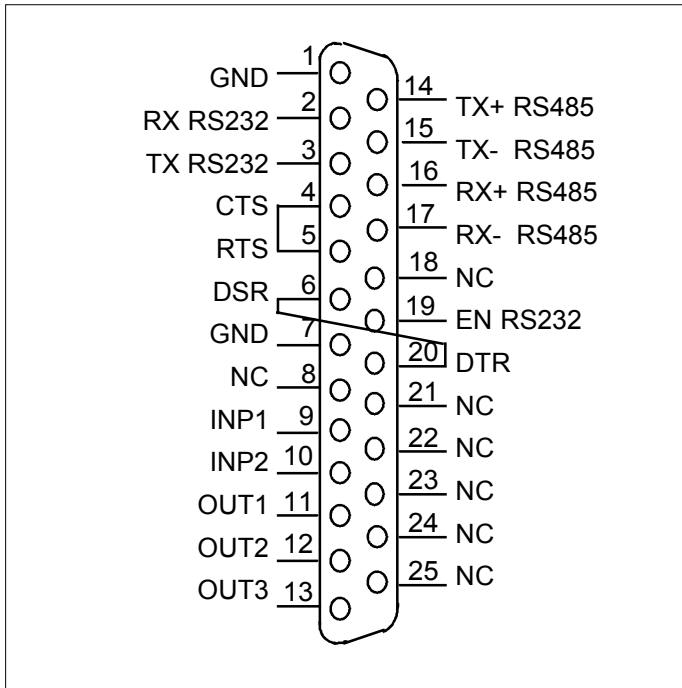

Figure 7.1.3 - Serial-I/O Port Pin Designation.

### Serial-I/O Port Pin Designations

**Digital Outputs:** OUT1-OUT3.

Compatibility: TTL. Connect between output and

ground.

Output Assignments: OUT1 - Normally ON, Turned OFF on load overrange or sample break.

All other outputs undefined.

**Digital Inputs for Load Cell Select:**

INP1(pin 9) & INP2 (Pin 10).

Pull to GND to Close.

#### Load Cell Select Table

	inp1	inp2
LC0	Open	Open
LC1	Closed	Open
LC2	Open	Closed
LC3	Closed	Closed

**RS232 Serial Port:** Use pins 2, 3 and 7.

Protocol: 9600 baud, 8 data, 1 stop, no parity

For RS485 operation connect pin 19 (EN RS232) to GND.

Connect all shields to chassis.

## 7.2 Serial-I/O Port

The Serial I/O port is used to transmit test results to a serial printer or computer. It also has three digital outputs. Output1 (pin 11) is normally on and will turn off on sample break or load overrange.

## 7.3 Power (DC) Input

The **Gauge Buster Plus** requires a 7-15Vdc unregulated input voltage. Contact ADMET if the factory supplied power source is not used.

# 7.4 Mounting Dimensions

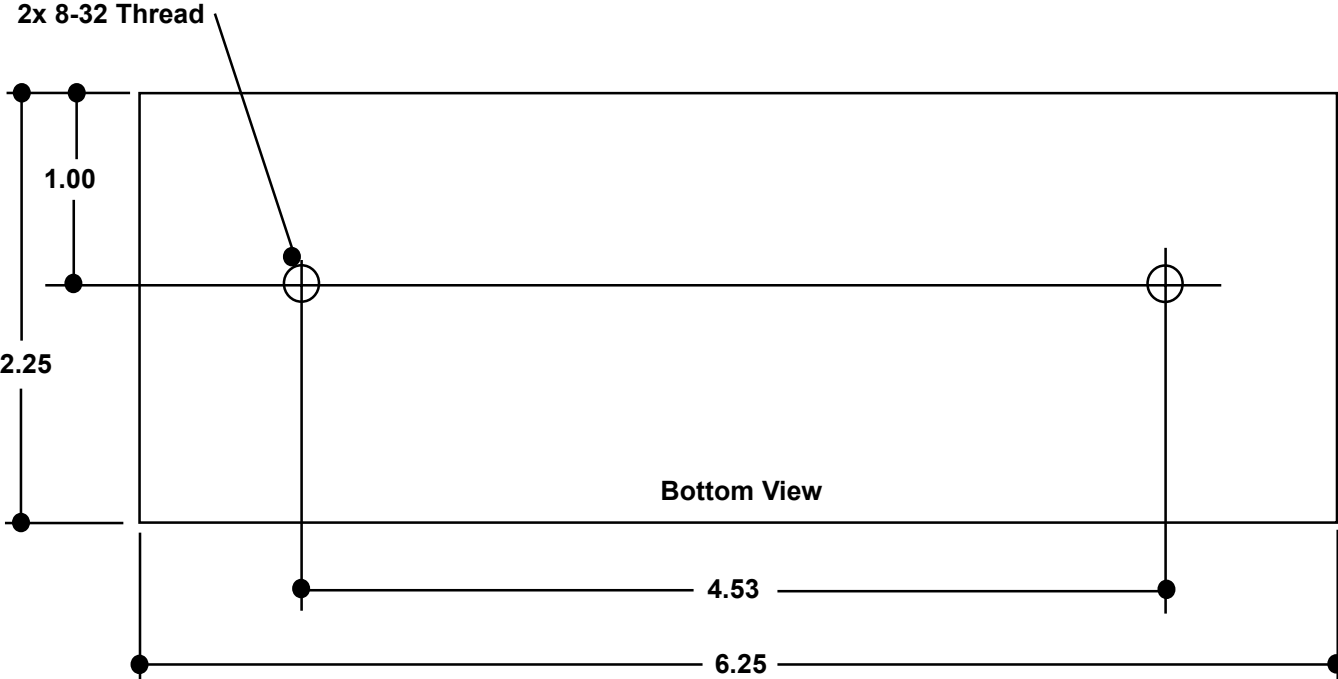
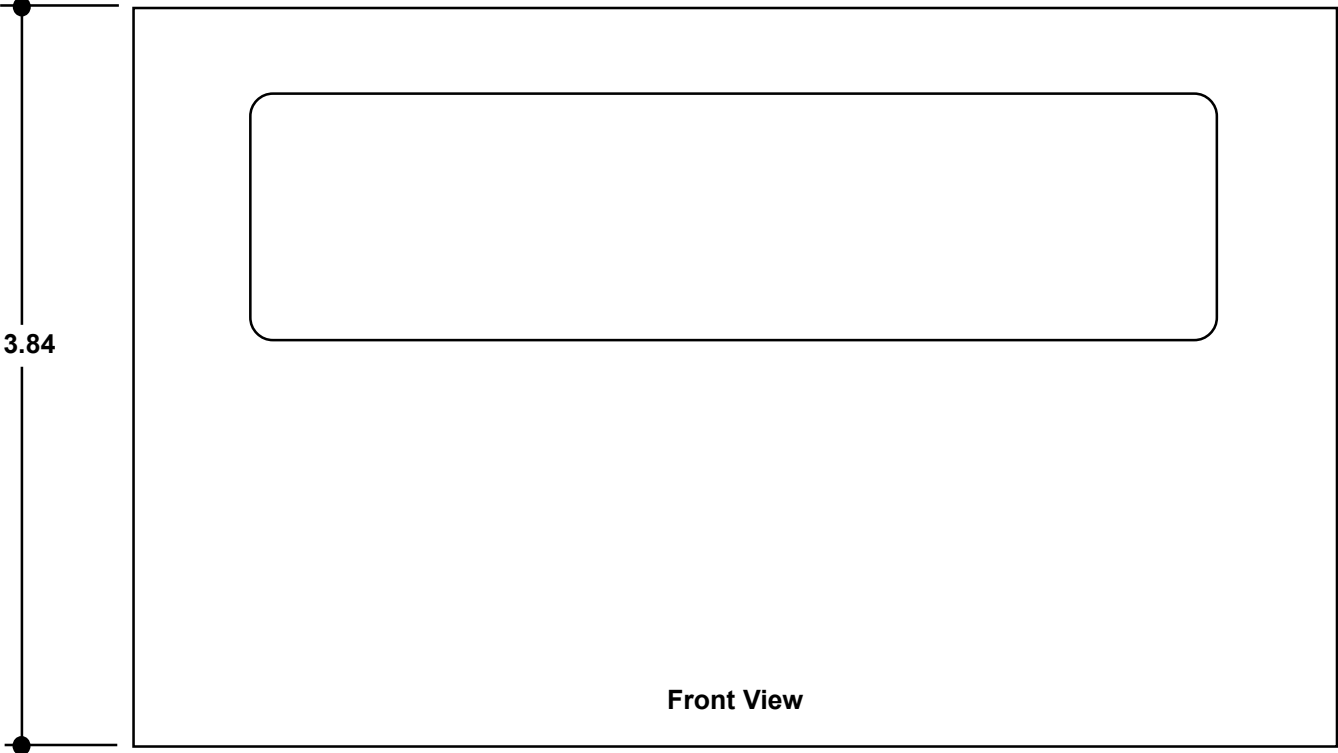

## 7.5 Password

**Factory Password: 268**

Use this for calibration and other password protected areas, except **Set Load Cell** in **SETUP** menu.

Password for Load Cell Select: 157

ADMET suggests removing this page from the manual and placing it in a safe place.

# Index

## A

Analog Transducer Pin Designation 16  
ASTM C39 4  
ASTM E4 4  
Auto-Transmit Results 4

## C

Calibrate 8  
Check Transducer 8  
Clear Results 8

## D

Data Logging Threshold 7

## E

Edit Calibration Points 8  
Engineering Units 7

## H

How to Perform a Test and Save Results 9  
How to Setup a Test 9

## I

Indicator 4  
Install Defaults 8

## P

Password: 19  
Print 8. *See also* WinCom  
Print Cals 8

## R

Raw Data -> WC+ 8  
Report Options 8  
Results -> Prn 8  
Results -> WC+ 8

## S

Sample Brk 7  
Serial-I/O Port Pin Designation 17  
Set Baud Rate 8  
Set Date and Time 8  
Set Load Cell 7  
Specimen Type 7  
Store 7  
Stream -> Com 8

## T

Threshold 7

## W

WinCom 8. *See also* Print