



Morehouse
THE FORCE IN CALIBRATION SINCE 1925

PM-5301
Rev. 3/2022

ISO/IEC 17025 / ANSI/NCSLI Z540.3 Accredited

Operation and Instruction Manual

Universal Scale Calibrator



Model USC-60K



Morehouse Instrument Company, Inc.
1742 Sixth Ave., York, PA 17403-2675 USA



P: (717) 843-0081
F: (717) 846-4193



info@mhforce.com
www.mhforce.com



Table of Contents

General Specifications	3
Assembly Instructions	6
Operating Instructions	7
Maintenance Instructions	8
Certificate of Capacity Load Test and Overload	10
Recommended Mounting Adapters	11

General Specifications

1. Scope

The Universal Scale Calibrator is for the application of compression loads up to 60,000 lbf. The calibrator is designed to calibrate and perform corner tests on aircraft wheel platform scales with dimensions up to 38.5 x 38 x 4.625 in. (978 x 965 x 117 mm).

2. Compatibility

This calibrator is designed to calibrate aircraft wheel platform scales with capacities up to 60,000 lbf, using specific sizes of standard load cells.

3. Design Requirements

The calibrator consists of a frame assembly with a motorized adjustable crosshead, a hydraulic force application system consisting of a hydraulic jack with a hand pump, and mounting adapters. The calibrator is designed to apply a force through a standard load cell fastened to the hydraulic jack. Load cells are not included.

4. Performance & Product Characteristics

4.1 Functional Requirements

The calibrator is a floor-mounted unit. Optional legs are available with leveling feet to raise the platen working area to approximately 29 inches from the floor. The calibrator is used for the calibration of aircraft wheel load scales from 1,000 to 60,000 lbf.

4.2 Capacity

The calibrator has a working (rated) capacity of 60,000 lbf.

4.3 Overload

The calibrator has been proof loaded 25% above the working capacity of 60,000 lbf. However, the working (rated) capacity of 60,000 lbf should not be exceeded.

5 Details of Components

5.1 Frame Assembly

The frame assembly consists of a mounting base with a platen, threaded tension tie bars, and a moveable crosshead. The useable area of the platen is 58 inches long by 40.5 inches wide. The platen is drilled with a 1 inch diameter center hole. The moveable crosshead adjustment range permits the hydraulic jack ram to be positioned between not less than 6 inches and 24 inches from the top of the platen. The crosshead height above the platen is adjusted using the electric motor on the top beam. The motor operates on 115 volts, 60 cycle, single phase power.

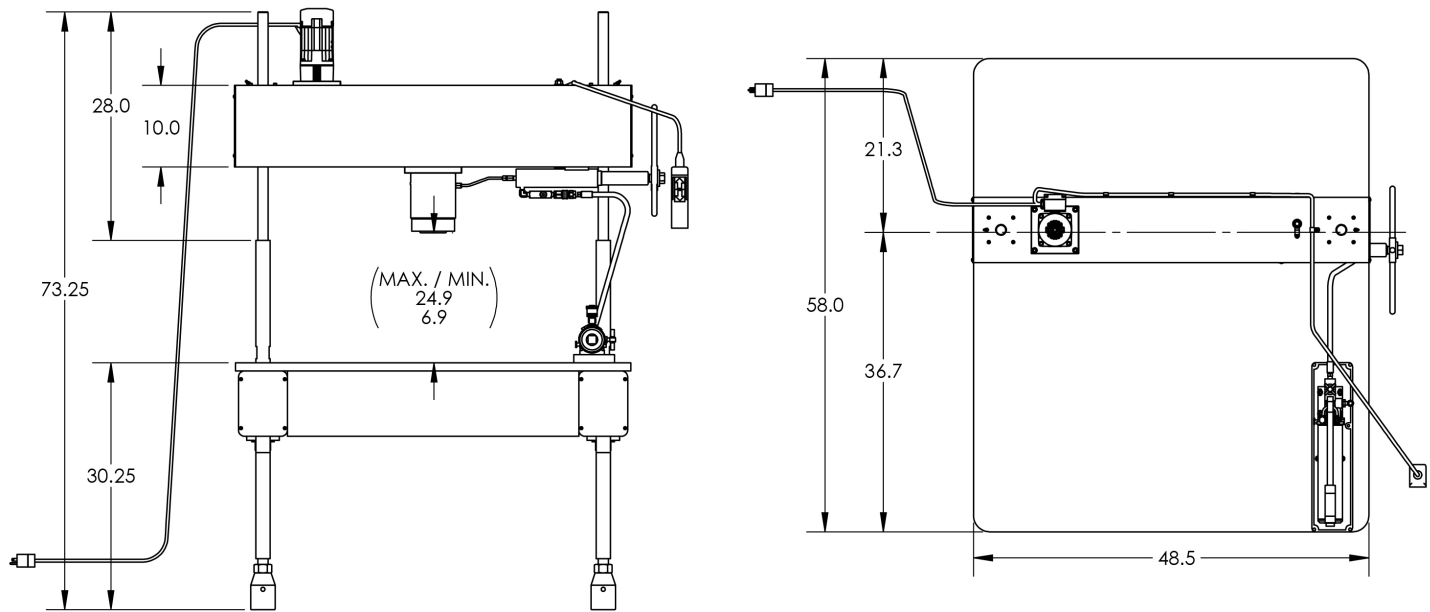

Figure 1: Dimensions of 60,000 lbf Universal Scale Calibrator



5.2 Hydraulic Force Application System

The hydraulic force application system consists of a 60,000 lbf capacity Morehouse hydraulic jack that is mounted on the moveable crosshead. The jack is used to apply a vertical force between the adjustable crosshead and the platen, which is where the scale that is being calibrated is placed.

5.2.1 Hydraulic Jack

The hydraulic jack has a working capacity of 60,000 lbf. It is specially designed to have the lowest possible leak rate so it is suitable for force calibration work. The jack ram is provided with threaded adapters for fastening the load cell standards to the jack ram. The jack ram has a vertical stroke of 1 inch, and will fully retract when hydraulic pressure is released.

5.2.2 Hand Pump

The hydraulic jack is activated by a hand pump, which has a vernier screw piston. The pump is connected to the jack with a hydraulic hose that has a quick disconnect on one end.



Figure 2: Hand Pump for Universal Scale Calibrator

Assembly Instructions

1. The calibrator is crated for shipment with the legs unattached from the frame. Remove the calibrator from the shipping crate and attach the legs to the frame.
2. Move the calibrator to the desired location and level the platen table using the adjustable feet. The calibrator weighs approximately 1,600 pounds, and is designed to sit directly on the floor.
3. The hand pump has been fastened to the machine platen for shipping. Remove the hand pump from the platen by removing the two screws holding the hand pump drip pan to the platen.
4. The top surface of the platen, and the unthreaded portion of the tie bars, have been coated with a rust inhibitor. This is removed using mineral spirits. After the rust inhibitor has been removed, these surfaces should be coated with light oil to prevent rust and corrosion.
5. Before using the calibrator, check the hydraulic force application system.

5.1 Check the hydraulic fluid in the hand pump by removing the fill plug. The fill plug should be left open about two turns during operation. If hydraulic fluid must be added, be sure to use petroleum base anti-wear hydraulic fluid with an ISO Viscosity Grade of 22 or 32. The following hydraulic fluids are recommended, but any equal hydraulic fluid may be used:

Arco	Dutro AW 32
Conoco	Super Hydraulic 32
Drydene Oil Co	Paradene 22 AW
Exxon	Nuto H 32
Gulf	Harmony 32 AW
Mobil	DTE 24
Texaco	Rando HD 32

5.2 Prepare the hydraulic jack for use. The hydraulic jack is furnished with a self-sealing hose coupling and has been fully bled and checked at the factory prior to shipment. However, if the hand pump and hydraulic jack seem “spongy” during use, then there may be air in the system. If this occurs, bleed the system of entrapped air using the procedure outlined in the Maintenance section of this manual.

Operating Instructions

1. Adjust the height of the crosshead to allow space between the calibrator's platen and the hydraulic ram for the load cell to be installed. Use the momentary pendant switch with electric motor to raise and lower the crosshead. The motor operates on 115 volts, 60 cycle, single phase power. An 220 volt, 50 cycle, single phase motor is available as an option.
2. Fasten the base of the load cell to the hydraulic ram using the $\frac{3}{4}$ -16 threaded adapter. This adapter has been screwed into the jack for shipping and should always be kept there when not in use. Be sure the load cell is turned completely into the threaded adapter and there is no space between the base of the load cell and the hydraulic ram. The base of the load cell must be tight against the hydraulic ram.
3. Raise the adjustable crosshead and place the aircraft wheel platform scale to be calibrated on the calibrator's platen. The scale should be centered on the platen.
4. Use the appropriate loading blocks as specified by the calibration procedure for the scale to be calibrated. Center the 6 inch diameter compression pad supplied with the calibrator on the loading blocks. The side with the machined pocket should be up. Next place the load cell's load button on the 6 inch diameter compression pad. The load button should fit in the pocket machined in the 6 inch diameter compression pad.
5. Adjust the height of the crosshead so there is approximately $\frac{1}{8}$ inch clearance between the spherical radius of the load button and the mating radius on the load cell. Be sure the load button is properly positioned to mate with the spherical radius of the load cell.
6. The desired forces are now applied. The hand pump is used to activate the hydraulic jack. This pump functions similar to other hand pumps. With the pump connected to the hydraulic jack, operating the hand lever causes hydraulic oil from the reservoir of the pump to be pumped to the hydraulic jack. During pump operation, the fill plug on the upper right side of the pump body should be open about two turns to serve as a reservoir vent. To operate the hand pump, the relief valve must be closed. To close the relief valve, turn the handle toward the hose connection of the pump body.
7. The hand pump is a dual volume design based on a double diameter piston. On the side of the hand pump is a valve rod. With the rod pulled out, the full diameter of the piston is effective for low pressure, high volume pumping. With the rod pushed in, the reduced diameter is effective for high pressure, low volume pumping with minimum effort. **Caution: Before pushing the rod in, release any downward pressure applied to the hand lever.**

8. After the pressure has been pumped up with the hand lever, adjust to the approximate force desired. Use the star wheel of the Vernier screw piston to obtain and maintain the exact force required. **Caution: Do not exceed the one-inch stroke of the jack ram, or considerable damage will result.**
9. After the desired forces have been applied, to release the pressure turn the handle of the relief valve toward the back of the pump body. This will release pressure and the jack ram will return automatically.

Maintenance Instructions

1. The top surface of the platen, the unthreaded portion of the tie bars, and the face of the jack ram should be kept coated with a light oil to prevent rust and corrosion. We recommend these areas be wiped with light oil after each use.
2. The calibrator should be given a routine service inspection at regular intervals, the frequency of which depends upon how often and under what circumstances it is used. During this inspection, check the equipment for rust, leaking hydraulic fluid, and other visible signs of deterioration or damage. The inspection should include a visible inspection of all welds on the upper frame beam. Be sure to check all nuts, bolts, and screws to ensure they are tight. Check the oil level in the pump reservoir, and examine the o-ring seals. Replace any ring that is split, cut, or otherwise damaged. After an extended period of heavy service, it is advisable to disassemble and clean the pump. Cleaning the pump consists simply of washing or blowing out the body casting and washing the parts. Refer to step 6 below for disassembly instructions.
3. Routine maintenance of the machine includes replacing O-ring seals in the pump assembly, adding hydraulic fluid if required, removing rust, dirt and corrosion from all assemblies, touching up paint damage, tightening any nuts or set screws which have loosened, and re-leveling. If the pump and jack assembly fail to develop or hold pressure, corrective maintenance may be necessary.
 - 3.1. If the hand lever is operated and the pump fails to develop pressure, be sure the relief valve is closed and there is sufficient fluid in the reservoir. If failure continues, then one or both of the check valves may be leaking. Replace both o-rings to be sure.
 - 3.2. If the pump builds up pressure but the pressure drops, then examine all joints for leakage; a very small amount of leakage will result in considerable loss of pressure. As the pressure drops, watch the hand lever. If it rises, the discharge check valve is leaking. Replace the o-ring (29). If the hand lever does not rise as the pressure drops, then the relief valve is leaking. A foreign particle may be lodged on the seat, but more likely the o-ring (39) has failed and must be replaced.

3.3 The outlet in the pump body is tapped with **9/16-18 SAE ORB (-6)** thread and machined for o-ring seals (15). A firm joint will prevent leakage. If leakage develops do not tighten the fitting excessively; replace the o-ring seal. **Caution: Do not screw pipe threads directly into the pump body outlet. The special adapter (53) is provided with pipe threads for making connections.**

4. Routine lubrication consists of adding a few drops of oil to the chain drive on the upper frame and applying grease to any grease fittings. The grease used should conform to NLGI 2 specifications.

5. If the hand pump and hydraulic jack seem rather “spongy” during use there may be air in the system. If this occurs, bleed the system of entrapped air. To bleed the hydraulic jack, remove it from the calibrator and place it on its side on a suitable work surface, then proceed as follows:

5.1 Check the supply of fluid in the pump reservoir by removing the fill plug (item 30). The fill plug must be left open about two turns during operation to serve as a reservoir vent. If hydraulic fluid must be added, then use petroleum base anti-wear hydraulic fluid with an ISO Viscosity Grade of 22 or 32, as recommended in the Assembly Instructions.

5.2 With the hydraulic hose disconnected from the hydraulic jack, and connected only to the hand pump, pump the hydraulic hose full of hydraulic fluid. The poppet of the hose half of the self-sealing quick-disconnect coupling must be depressed to accomplish this.

5.3 Connect the hydraulic hose to the jack cylinder fitting, and pump the jack ram out to full stroke, approximately 1 inch.

5.4 Roll the jack to bring the air bleed location to the highest point.

5.5 Alternately, open the air bleed and roll the jack back and forth. The ram return spring will keep sufficient pressure on the fluid to purge the air.

5.6 After the jack has been bled of all entrapped air, tighten the air bleed securely, and return the jack to its original position on the calibrator.

6. Servicing the hand pump includes replacing the o-rings, seals, and cleaning. When changing o-rings, always lubricate the o-rings, and all contacting metal parts before attempting assembly. For a lubricant, use the same fluid that will be used in the system.

The high pressure valve poppet and retaining parts are held in place by the retaining plug (57). To reassemble, screw the retaining plug (57) into the body until all parts are solid, then back it off about two turns. This provides sufficient travel for the poppet.

7. All parts of the calibrator (except o-rings and seals) are designed to last indefinitely in normal use. Inadvertent misuse or accidental damage may occur in which case repair may best be effected by replacing the damaged parts.

8. Parts typically needed for maintenance or replacement are:

Item	Description
HYD:692000SK	Hand Pump Seal Kit
HYD:139000SK	60k lbf Hydraulic Jack Seal Kit
HYD:USJ-60MD-200-01	60k Hydraulic Jack

Order parts from:

Service Department
Morehouse Instrument Company
1742 Sixth Avenue
York, PA 17403-2675 U.S.A.

Certificate of Capacity Load Test and Overload

This certifies the Universal Scale Calibrator was tested for capacity and overload.

The Universal Scale Calibrator was loaded to its rated working capacity of 60,000 lbf, and held for five minutes.

The calibrator was also proof loaded to 75,000 lbf, 25% above its working capacity.

Recommended Mounting Adapters

The Scale Reference Mounting Kit (SRK) includes recommended adapters for the reference standard in a Universal Scale Calibrator.

The kit includes:

1. Detent pin
2. Base thread adapter
3. Ball adapter
4. Ball cup

English units (lbf)

The kit is designed around Morehouse Shear Web load cells. Capacities are approximately 2K lbf, 25K lbf, 60K and 100K lbf. Note: The 100K load cell can only be used to 60,000 lbf capacity.

Load Cell	2,000 - 10,000 lbf	25,000 - 50,000 lbf	60,000 lbf	100,000 lbf
Order Code	SRK-10k	SRK-50k	SRK-60k	SRK-100k

SI units (kN)

The kit is designed around Morehouse Shear Web load cells. Capacities are approximately 20 kN, 100 kN, 250 kN and 500 kN. Note: The 500 kN load cell can only be used to 250 kN capacity.

Load Cell	20 - 50 kN	100 -200 kN	250 kN	500 kN
Order Code	SRK-50kN	SRK-200kN	SRK-250kN	SRK-500kN

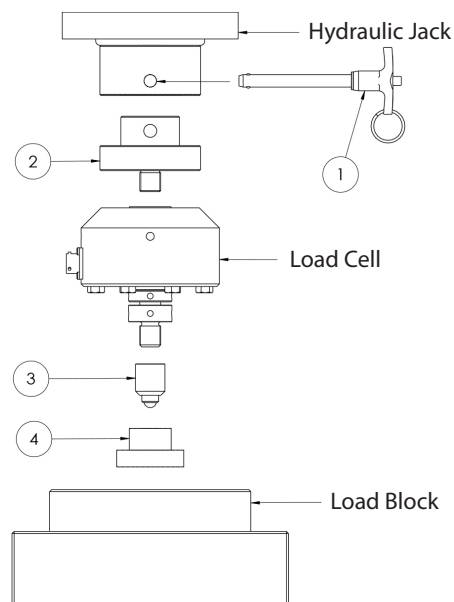

Figure 3: Scale Reference Mounting Kit