



Morehouse
THE FORCE IN CALIBRATION SINCE 1925

Morehouse Instrument Company
1742 Sixth Ave.
York, PA 17403-2675
(717) 843-0081

Morehouse Instrument Company is ISO/IEC 17025 / ANSI/NCSLI Z540.3 Accredited

www.mhforce.com

G501F Indicator Instruction Manual



G501F Indicator
Instruction Manual PM-4105



Morehouse Instrument Company
1742 Sixth Ave.
York, PA 17403-2675
(717) 843-0081

Morehouse Instrument Company is ISO/IEC 17025 / ANSI/NCSLI Z540.3 Accredited

www.mhforce.com

Contents

Display & Keypad Details.....	3
Installation & Overview	5
Installation	5
Getting Started	6
Instrument Configuration.....	7
Configuration Menus	7
Entering the Setup (“F”) Configuration Menu.....	7
Setup (“F”) Menu Descriptions	8
Entering the User (“A”) or COM (“C”) Menu.....	10
User (“A”) and COM (“C”) Menu Descriptions.....	11
Instrument Calibration	12
Calibration Overview	12
Live Calibration Overview.....	12
Live Positive Span Calibration Instructions (F17)	12
Live Negative Span Calibration Instructions (F15)	13
Live Zero Calibration Instructions (F16).....	14
Key-in mV/V Calibration Instructions (F27).....	14
Advanced Operation	16
Peak Hold Mode.....	16
Serial Port Information	16
Serial Port Modes.....	16
Output Strings.....	17
Specifications	18
Error Messages.....	19
Troubleshooting	19



Display & Keypad Details

This instrument uses a 6-digit LCD (Liquid Crystal Display) with adjustable LED backlight. The Table below summarizes the display annunciators.



Symbol	Display Indication
→0←	Displays when the instrument reading is at Zero.
P	The instrument is in Peak Hold mode.
lb	The displayed force reading is in pounds (lbf).
kg	The displayed force reading is in kilograms (kgf).
g	The displayed force reading is in grams (gf).
oz	The displayed force reading is in ounces (ozf).
	The displayed force reading is in Newtons (N).
k	The displayed force reading is in Kilonewtons (kN).
klb	The displayed force reading is in Kilopound (klbf).
▲▼	Displays whenever the instrument reading is at rest, i.e., not in motion.
🔋	When blinking, the battery life of the instrument has reached its useful end and <u>needs to be replaced</u> soon.
N	The displayed reading is negative.

The keypad comprises five (5) function keys.



Marking	Keypad Function
Units	Selects the displayed unit of measure, e.g., lbf, kgf and N. When using the Units button, you can only switch between specific units depending on the unit used when programming the instrument. The units in correlation are: (lbf, kgf, N), (kN, klb), (ozf, gf)
Peak	Selects the peak hold display mode of the instrument, e.g., live data, positive peak, and negative peak. (This function must first be enabled using the F36 parameter)
Zero	Zeroes the force display reading.
Data	Sends the displayed data to the serial communication port.
On/Off	Press and hold for a few seconds to turn the instrument ON. Press and hold for about five seconds to shut the instrument OFF.



Installation & Overview

Remember that the installer is ultimately responsible to assure that a particular installation will be and remain safe and operable under the specific conditions encountered.

The instrument must be properly configured and calibrated prior to use.

Installation

Find a suitable location for the instrument and use the included bracket to mount the unit to a wall or table. Use this handy guide for mounting the bracket to a wall or table:

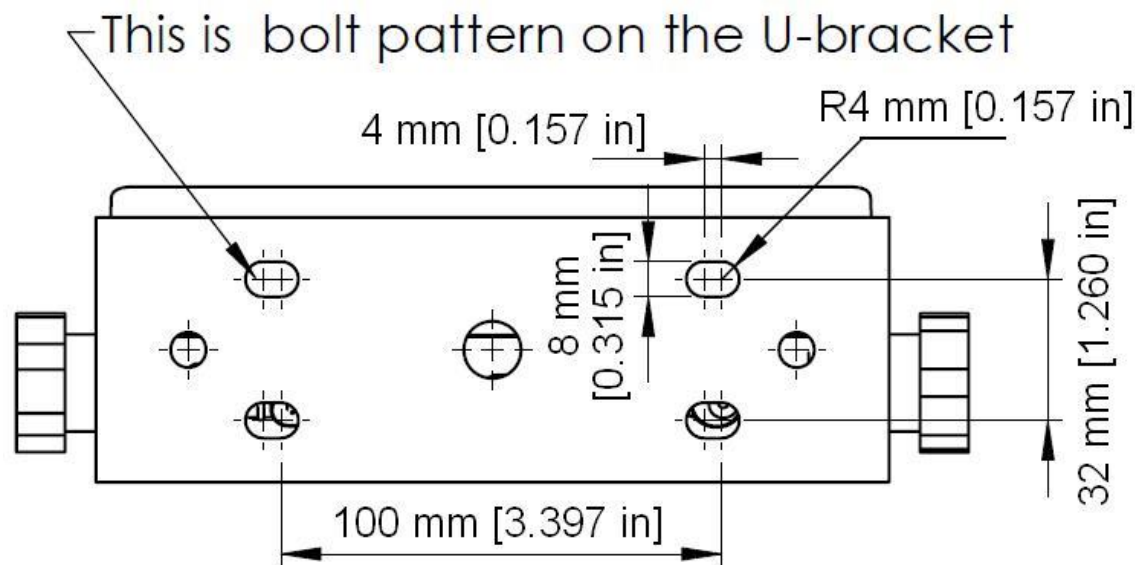

When the indicator is not ordered with a load cell, use the following color codes to connect the force sensor.

Force Sensor Cable Leads

Color	Function	Color	Function
Black	- Excitation	White	+ Signal
Red	+ Excitation	Green	- Signal



The INSTRUMENT features one full duplex RS-232 serial port, designed for connection to a computer or a serial printer. The same port may be also used as a simplex, RS-232 port designed for connection to a remote display.

DSUB9 Connector

Pin No.	Wire Name
2	RXD
3	TXD
5	Ground

When using batteries to power the instrument, it requires 4-AA batteries to operate (not included). To install the batteries, remove the plastic battery cover from the rear panel. Observe proper direction (polarity) of the batteries. Replace the battery cover.

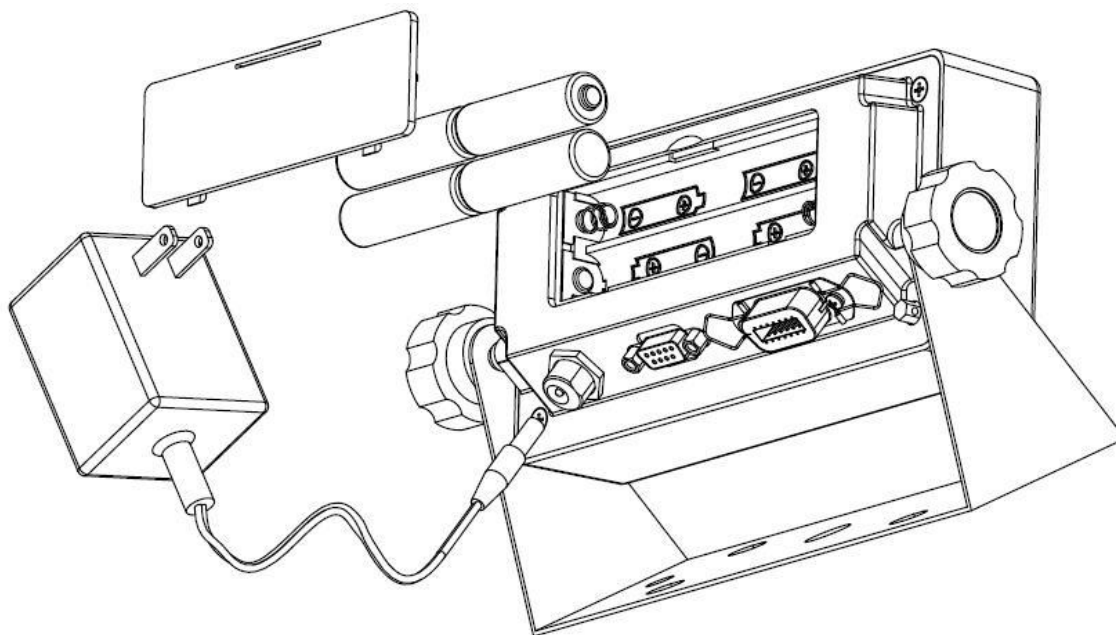

The INSTRUMENT may also be powered by the included AC wall adaptor.

Getting Started

1. Press and hold the ON/OFF key on the instrument for two seconds.
After a brief initialization period, the instrument will revert to a zero ("0") force display.

Your instrument is now ready for configuration and calibration.

Instrument Configuration

Configuration Menus

The G501F contains three menus to configure the instrument:

Setup (“F”) Menu – Configures all metrologically-related parameters including calibration procedures.

User (“A”) Menu – Configures COM2 communication parameters and other misc. parameters, e.g., automatic turn off.

COM1 (“C”) Menu – Configures COM1 communication parameters.

The configuration menus are laid out in the following vertical arrangement:

- Top [Menu selection] level
- Parameter level
- Selection level (or function level, e.g., span calibration)

Please review the following chart to get a feel for how to navigate among the various menus and parameters.

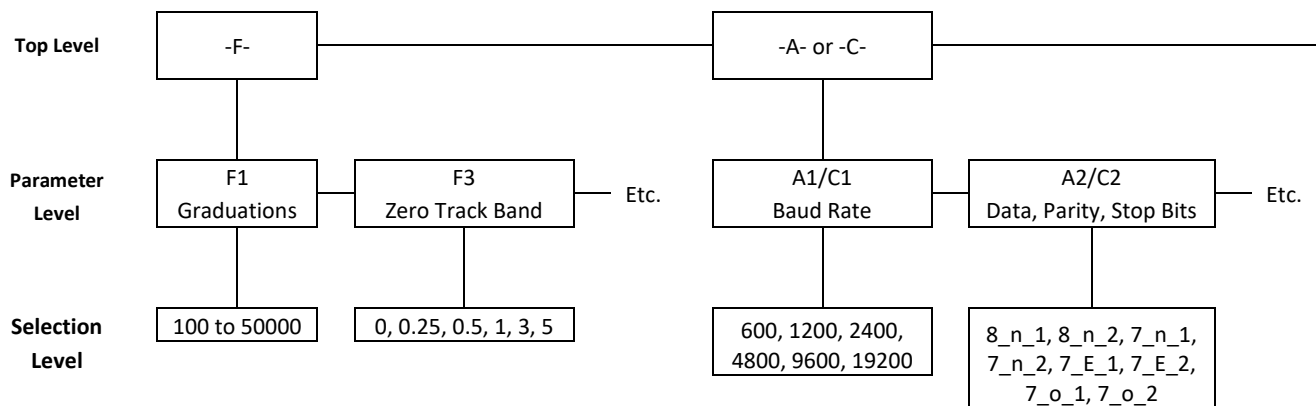

Entering the Setup (“F”) Configuration Menu

1. Switch off the instrument by pressing and holding down the ON/OFF key for about 5 seconds.
2. Press and hold down the ON/OFF key (about 20 seconds) until the screen shows “-F-”.
3. Scroll down using the PEAK (down) key to reach the parameter level. The instrument shows “F 1”.
4. Move from one “F” menu parameter to the next by using the DATA (left) or ON/OFF (right) keys. For example, to go from F1 to F2, press the ON/OFF key. To go from F2 back to F1, press the DATA key.

5. Once you have arrived at the proper “F” menu parameter, e.g., “F 1”, press the PEAK (down) key once to arrive at the selection level. The instrument displays the current parameter setting.
6. If there is a selection list, scroll thru the available parameter settings, use the DATA (left) or ON/OFF (right) keys. Otherwise, use the arrow keys to adjust the displayed value to the new value.
7. Once the setting you want is displayed on the screen, press the ZERO (set) key to save this value and revert up to the parameter level, e.g., “F 1”.

To save all parameter settings, it is imperative to exit all menus in the following manner: At the parameter level, press the UNITS (up) key twice (two times) to exit the Setup Menu. The instrument displays ‘SET’ and then automatically powers off.

Setup (“F”) Menu Descriptions

This section provides more detailed descriptions of the selections found in the Setup Menu Chart. Factory-set defaults are shown in **bold** with a checkmark; (√).

CODE/NAME	DESCRIPTION	SELECTION LIST
F1 Graduations	Sets the number of full-scale graduations, i.e., capacity ÷ division. DO NOT CHANGE	Key-in 100 - 50000 50000 √
F2 Sampling Rate	Sets the sampling rate in Hertz (measurements per second).	Key-in 1 – 1200.00 100.00 √
F6 Digital Filter	Sets the number of measurements to be averaged to affect the speed and stability of the readings. A lower number provides a faster response. Choose the value that works best for your application.	0 to 12 8 √
F8 Calibration Unit	Sets the force unit of measure to be used in the calibration process. Also, the default unit for normal operation. "1" = primary unit is lbf "2" = primary unit is in kgf "3" = primary unit is ozf "4" = primary unit is in gf "6" = primary unit is kN "7" = primary unit is in klf Use “1” for Newtons then choose “5” in the F35 menu.	1√ 2 3 4 6 7
F9 Display Divisions	Sets the interval value. Use together with F10.	1√ 2 5
F10 Decimal Pt.	Sets the decimal point value. Use together with F9.	0√ 0.0 0.00 0.000 0.0000 00

CODE/NAME	DESCRIPTION	SELECTION LIST
F15 Span Calibration - Negative	Places instrument into live negative (-) span calibration mode. Scrolling down with the PEAK key one level begins the procedure.	Press PEAK key to begin sequence
F16 Zero Calibration	Places instrument into live zero-calibration mode. Scrolling down with the PEAK key one level begins the procedure.	Press PEAK key to begin sequence
F17 Span Calibration - Positive	Places instrument into live positive (+) span calibration mode. Scrolling down with the PEAK key one level begins the procedure.	Press PEAK key to begin sequence
F18 View Calibration Data	Activates the function that allows you to view calibration values. Scrolling down with the PEAK key one level begins the procedure.	Press PEAK key to begin sequence
F19 Key-in Zero	Allows you to key-in a known zero calibration value. Scrolling down with the PEAK key one level begins the procedure.	Press PEAK key to begin sequence
F20 Key-in Span	Allows you to key-in known span calibration values. Scrolling down with the PEAK key one level begins the procedure.	Press PEAK key to begin sequence
F21 Factory Reset (US)	This sub-menu will reset all parameters in the "F" and "A" menu to the default settings. It will not overwrite any previously saved calibration data. USE WITH CAUTION!	Press the PEAK key twice to execute
F22 Factory Reset (EU)	This sub-menu will reset all parameters in the "F" and "A" menu to the default settings. It will not overwrite any previously saved calibration data. USE WITH CAUTION!	Press the PEAK key twice to execute
F23 Full Factory Reset	This sub-menu will reset all instrument parameters to the default settings. It will not overwrite any previously saved calibration data. USE WITH EXTREME CAUTION!	Press the PEAK key twice to execute
F25 Set Point Function	Sets the function of the set points and relay outputs.	0 to 10 0 √
F26 Calibration Mode	Sets the instrument calibration mode. "no" = Live, "yE5" = Key-In (mV/V)	no √ yE5
F27 Key-in Calibration	Places instrument into key-in (mV/V) calibration mode. Scrolling down with the PEAK key one level begins the procedure.	Press PEAK key to begin sequence
F28 Reference Calibration	Places instrument into reference (mV/V) calibration mode. Scrolling down with the PEAK key one level begins the procedure. Password protected.	Press PEAK key to begin sequence

CODE/NAME	DESCRIPTION	SELECTION LIST
F30 Application	Sets one special application. "0" = None (Gross/Net), "2" = Remote Display, "5" = Peak Hold, "	0 2 5√
F31 Quick Cal.	Sets the calibration stability level. Enable for hydraulic sensor Calibration. "no" = Disabled "yes" = Enabled	No √ YES
F35 Default Units Mode	Sets the force unit of measure to be displayed when the instrument is switched on. Scrolling down with the PEAK key one level begins the procedure. "1" = Pounds (lbf), "2" = Kilograms (kgf), "3" = ounces (ozf), "4" = grams (gf), "5" = Newtons (N) "6" = Kilonewtons (kN) "7" = Kilopound (klb)	1√ 2 3 4 5 6 7
F36 Default Peak Mode	Sets the peak hold mode to be activated when the instrument is switched on. Scrolling down with the PEAK key one level begins the procedure. "rEAL" = Live, "HoLd P" = Positive Peak, "HoLd U" = Negative Peak	rEAL√ HoLd P HoLd U

Entering the User ("A") or COM ("C") Menu

NOTE: Follow the same steps to enter the COM ("C") Menu– just substitute "C" for "A" below

1. Switch off the instrument by pressing and holding down the ON/OFF key for about 5 seconds.
2. Press and hold down the ON/OFF key (about 20 seconds) until the screen shows "-F-".
3. Press the ON/OFF (right) key once. The screen displays "-A-".
4. Scroll down using the PEAK (down) key to reach the parameter level. The instrument shows "A 1".
5. Move from one "A" parameter to the next by using the DATA (left) or ON/OFF (right) keys. For example, to go from A1 to A2, press the ON/OFF key. To go from A2 back to A1, press the DATA key.
6. Once you have arrived at the proper "A" menu parameter, e.g. "A 1", press the PEAK (down) key once to arrive at the selection level. The instrument displays the current parameter setting.
7. If there is a selection list, scroll thru the available parameter settings, use the DATA (left) or ON/OFF (right) keys. Otherwise, use the arrow keys to adjust the displayed value to the new value.
8. Once the setting you want is displayed on the screen, press the ZERO (set) key to save this value and revert up to the parameter level, e.g. "A 1".
9. To save all parameter settings, it is imperative to exit all menus in the following manner: At the parameter level, press the UNITS (up) key twice (two times) to exit the User Menu. The instrument displays 'SET' and then automatically powers off.

User ("A") and COM ("C") Menu Descriptions

This section provides more detailed descriptions of the selections found in the User Menu Chart. Factory-set defaults are shown in **bold** with a checkmark; (✓).

CODE/NAME	DESCRIPTION	SELECTION LIST
A1/C1 Baud Rate	Selects the baud rate for data transmission through the serial port.	600, 1200, 2400, 4800, 9600 ✓, 19200, 38400, 57600, 115200
A2/C2 Data Bits, Parity and Stop Bits	Selects the number of data bits and parity of serial transmission. "8_n_1" = 8 data bits with no parity bit and one stop bit "8_n_2" = 8 data bits with no parity bit and two stop bits "7_n_1" = 7 data bits with no parity bit and one stop bit "7_n_2" = 7 data bits with no parity bit and two stop bits "7_E_1" = 7 data bits with even parity bit and one stop bit "7_E_2" = 7 data bits with even parity bit and two stop bits "7_o_1" = 7 data bits with odd parity bit and one stop bit "7_o_2" = 7 data bits with odd parity bit and two stop bits	8_n_1 ✓ 8_n_2 7_n_1 7_n_2 7_E_1 7_E_2 7_o_1 7_o_2
A3/C3 Serial Port Mode	Selects the mode of the serial port: Refer to Serial Port Information for more details. "0" = Demand Full Duplex "1" = Continuous Full Duplex "2" = Auto Print	0 ✓ 1 2
A6/C6 Output String	Selects fixed output string for serial port. Refer to Serial Port Information for more details. "0" = String Format 1 (Condec Demand) "1" = String Format 2 (Condec Continuous) "2" = Text Print Ticket "3" = Text Print Ticket with MP-20 Auto Label Feed	0 ✓ (A6) 1 2 ✓ (C6) 3
A10 Auto Power Off	Selects the automatic power off time, expressed in minutes of inactivity (keys and force measurement change). Pressing the PEAK key to scroll down one level begins the sequence. (0 = No auto power off)	Key-in 0 to 30 30 ✓
A12 Backlight Brightness	Selects the brightness of the LCD backlight. Selections are in % of full brightness. Intended to help save battery life.	0 (OFF) 20 50 75 100 ✓
A22 Low Battery Auto Power Off	Selects the automatic power off time of the instrument after it enters a low battery condition. Expressed in minutes. Pressing the PEAK key to scroll down one level begins the sequence.	Key-in 0 to 99 2 ✓
A23 Audible Key Feedback	Selects function of the audible key feedback (beeper). "no" = Disabled "YES" = Enabled	no YES ✓

Instrument Calibration

Calibration Overview

There are two ways to calibrate the instrument.

*****Be sure to check (F26) to see if the correct calibration mode is chosen before continuing with your calibration.*****

1. **Live calibration:** You will be calibrating an actual load sensor to the instrument using live test loads. You can have up to seven positive calibration points and up to seven negative calibration points. These calibration points are denoted as C1 through C7.
2. **mV/V calibration:** You will be calibrating the instrument using a load cell simulator (calibrator). Previously established mV/V input signal values - and the corresponding force values - are required. You can have up to seven positive calibration points and up to seven negative calibration points. These calibration points are denoted as C1 through C7.

The absolute value of each subsequent calibration point should be higher than the last, e.g., the C2 value should be greater than the C1 value, etc.

Live Calibration Overview

Live calibration is comprised of 3 main steps as needed: **zero** calibration (F16), **positive span** calibration (F17) and **negative span** calibration (F15).

Here is a quick reference of the recommended sequence for multiple calibration points: **Follow the Live Span Instructions below for more details of the calibration.**

1. Put force sensor onto test fixture
2. Go to F17 and press the down key; indicator prompts for the first calibration point
3. key in number 111111 and press the SET key; indicator will show "FIT" momentarily and then automatically record the fixture reference point
4. Follow the F17 procedure as written for up to seven calibration points
5. If necessary, repeat these steps for negative span calibration (F15)
6. Mount the force sensor onto the final fixture
7. Go to F16 and perform zero calibration

Live Positive Span Calibration Instructions (F17)

1. To get in the menu, start with the meter powered off, then press and hold down the ON/OFF key (about 20 seconds) until the screen shows "-F-".
2. With "-F-" showing Press PEAK(down) to show "**F 1**", Then press ON/OFF to scroll to "**F 17**", (**This must be positive readings**) and then push PEAK (down) key. The indicator will briefly display '**C 1**' and then prompt you to enter the data for the first calibration point (C1). The previously saved force value will be displayed with one digit blinking.

3. Use the four directional keys to adjust the displayed value to 11111 and press the ZERO (set) key; indicator will show "FIT" momentarily and then automatically record the fixture reference point. The previously saved force value will be displayed with one digit blinking.
4. Place the first test load onto the force sensor.
5. Use the four directional keys to enter in the actual positive force value, e.g., 1000.0 lbf. Increase the flashing digit by pressing the UNITS key. Decrease the flashing digit by pressing the PEAK key. Pressing the DATA key or the ON/OFF key will change the position of the flashing digit. Press zero to save and proceed to the next point.
6. Repeat steps 3 through 5 to enter data for the remainder of the calibration points. **You need not enter data for all seven calibration points. To cease entering additional calibration points, simply enter zero for the new value, e.g., 0.0 lbf.**
7. At the conclusion of C7 (or the last calibration point), the instrument will show "-donE" and reverts to the top setup menu level, i.e.: "-F-".

If the calibration was *not* successful, one of the following error messages will appear.

- "Err0" - The calibration test load or the keyed-in load is larger than the full capacity of the instrument. Change the calibration test load or check the input data.
- "Err1" - The calibration test load or the keyed-in load is smaller than 1% of the full capacity of the instrument. Change the calibration test load or check the input data.
- "Err2" – There is not enough signal from the force sensor to complete the calibration process. Most common causes include incorrect force sensor wiring, a mechanical obstruction or a faulty (damaged) force sensor.

Take the indicated action to correct the problem, and then perform a new calibration.

*When both modes are needed for calibration, skip saving until all calibration is complete. Proceed to Live Negative Span Calibration Instructions.

To save all calibration settings, you must exit all menus in the following manner: At the parameter level, press the UNITS (up) key twice (two times) to exit the Setup Menu. The instrument displays 'SET' and then automatically powers off.

*If the meter does not read after programming, make sure the correct output is in the correct "F" menu. ("F15" needs to be negative and "F17" needs to be positive.)

Live Negative Span Calibration Instructions (F15)

For negative calibration data, you will not see a minus sign on the screen. You need not be concerned as all data entered is presumed to be a negative value, e.g., 1000.0 lbf is really -1000.0 lbf.

1. To get in the menu, start with the meter powered off, then press and hold down the ON/OFF key (about 20 seconds) until the screen shows "-F-".
2. With "-F-" showing Press PEAK(down) to show "**F 1**", Then press ON/OFF to scroll to "**F 15**", (**This must be negative readings**) and then push PEAK (down) key. The indicator will briefly display



"C 1" and then prompt you to enter the data for the first calibration point (C1). The previously saved force value will be displayed with one digit blinking.

3. Use the four directional keys to adjust the displayed value to 111111 and press the ZERO (set) key; indicator will show "FIT" momentarily and then automatically record the fixture reference point. The previously saved force value will be displayed with one digit blinking.
4. Place the first test load onto the force sensor.
5. Use the four directional keys to enter in the actual positive force value, e.g., 1000.0 lbf. Increase the flashing digit by pressing the UNITS key. Decrease the flashing digit by pressing the PEAK key. Pressing the DATA key or the ON/OFF key will change the position of the flashing digit. Press zero to save and proceed to the next point.
6. Repeat steps 3 through 5 to enter data for the remainder of the calibration points. **You need not enter data for all seven calibration points. To cease entering additional calibration points, simply enter zero for the new value, e.g., 0.0 lbf.**
7. At the conclusion of C7 (or the last calibration point), the instrument will show "-donE" and reverts to the top setup menu level, i.e.: "-F-".

To save all calibration settings, you must exit all menus in the following manner: At the parameter level, press the UNITS (up) key twice (two times) to exit the Setup Menu. The instrument displays 'SET' and then automatically powers off.

Live Zero Calibration Instructions (F16)

1. While in the Setup mode press PEAK(down), scroll to "F 16" using ON/OFF, and then scroll down once using the PEAK (down) key. The display will momentarily show "C 0" followed by a value. This value is the internal A/D count and can prove useful when trying to troubleshoot setup problems.
2. Mount the force sensor onto the final fixture, assure a no-load condition and then press the ZERO (set) key to save the zero-point value. The display will show "SET" and "EndC0" momentarily, and then revert up to F16.

To save all calibration settings, you must exit all menus in the following manner: At the parameter level, press the UNITS (up) key twice (two times) to exit the Setup Menu. The instrument displays 'SET' and then automatically powers off.

Underneath the display you may find down arrows which have been activated. For each down arrow displayed, add 1 million to the displayed count. (Max value is 4.8 million counts)

Key-in mV/V Calibration Instructions (F27)

*Make sure F26 is set to "Yes" prior to calibration.

You will be entering data for up to seven **positive** calibration points and up to seven **negative** calibration points. These calibration points are denoted as C1 through C7. The absolute value of each subsequent calibration point should be higher than the last.



Each calibration point requires entry of two values:

- A force value, e.g., 200 lbf
 - A corresponding mV/V input signal value, e.g., 1.0125 mV/V.
1. While in the Setup mode, scroll to "**F 27**", and then scroll down once using the PEAK (down) key. The indicator will briefly display 'Pos C' and then prompt you to enter the data for the first **positive** calibration point (C1). The previously saved force value will be displayed with one digit blinking.
 2. Use the four directional keys to enter in the actual positive force value, e.g., 200 lbf.
 3. Press the ZERO (Set) key to save the force value. The indicator will prompt you to enter the corresponding mV/V input signal. The previously saved mV/V value will be displayed with one digit blinking.
 4. Use the four directional keys to enter in the actual mV/V value.
 5. Press the ZERO (Set) key to save the mV/V value. The indicator briefly displays 'End C1' and then moves to the next **positive** calibration point (C2).
 6. Repeat steps 2 through 5 to enter data for the remainder of the **positive** calibration points. **You need not enter data for all seven positive calibration points. To cease entering additional calibration points, simply enter zero for both values, e.g., 0 lbf and 0.0000 mV/V.**
 7. The indicator will briefly display 'Neg C' and then prompt you to enter the data for the first negative calibration point (C1). The previously saved force value will be displayed with one digit blinking.
 8. Use the four directional keys to enter in the actual negative force value, e.g., 200 lbf. **For negative calibration data, you will not see a minus sign on the screen. You need not be concerned as all data entered is presumed to be a negative value, e.g., 200 lbf is really -200 lbf.**
 9. Press the ZERO (Set) key to save the force value. The indicator will prompt you to enter the corresponding mV/V input signal. The previously saved mV/V value will be displayed with one digit blinking.
 10. Use the four directional keys to enter in the actual negative mV/V value. **For negative calibration data, you will not see a minus sign on the screen. You need not be concerned as all data entered is presumed to be a negative value, e.g., 1.0125 mV/V is really -1.0125 mV/V.**
 11. Press the ZERO (Set) key to save the value. The indicator briefly displays 'End C1' and then moves to the next **negative** calibration point (C2).
 12. Repeat steps 8 through 11 to enter data for the remainder of the **negative** calibration points. **You need not enter data for all seven negative calibration points. To cease entering additional calibration points, simply enter zero for both values, e.g., 0 lbf and 0.0000 mV/V.**
 13. When all values are entered successfully, the display will show "**End Cx**" momentarily before reverting to F27.

To save all calibration settings, you must exit all menus in the following manner: At the parameter level, press the UNITS (up) key twice (two times) to exit the Setup Menu. The instrument displays 'SET' and then automatically powers off.

Advanced Operation

Peak Hold Mode

This mode is used to capture and hold peak forces recorded during a specific process. The most common application is evaluating the breaking point of a part or assembly. The instrument records both positive and negative peak forces.

This mode of operation is enabled by changing the F30 parameter setting to "5". In addition, consider configuring the F36 parameter setting to the desired peak mode after start-up (power on).

1. Push the PEAK key to activate positive peak mode; the instrument briefly displays "HoLd P" and then the "P" annunciator turns ON.
2. Apply force to the item under test. The display indicates and holds the positive peak force applied.
3. To activate negative peak mode, press the PEAK key again; the instrument briefly displays "HoLd U".
4. To reset both peak values to zero, press and hold the PEAK key for about 3 seconds until the display shows "Clr P".
5. To exit peak hold mode, press the PEAK key again; the instrument briefly displays "LiVE" and then the "P" annunciator turns OFF.

Serial Port Information

Serial Port Modes

DEMAND DUPLEX MODE

The Demand Duplex Mode provides a two-way serial transmission mode. In this mode, the output information is transmitted on demand; either by pressing the ON/OFF key on the instrument's front panel or upon receiving a recognized command from a host device (i.e., computer).

NOTE: Ensure that your cabling contains the proper handshaking.

CONTINUOUS DUPLEX MODE

The Continuous Duplex Mode provides a two-way serial transmission mode. In this mode, the output information is transmitted continuously making it a popular choice for remote displays and other remote devices requiring a constant data stream. The transmission automatically occurs at

the end of each display update. The instrument will react upon receiving a recognized command from a host device.

RECOGNIZED HOST COMMANDS (applies to both demand and continuous duplex modes)

- “P” - This command is sent to the instrument to print the indicated display.
- “Z” - This command is sent to the instrument to zero the instrument.
- “C” - This command is sent to the instrument to toggle among the configured units of measure.
- “M” – This command is sent to the instrument to print the Instrument model.
- “F” – This command is sent to the instrument to print the firmware version.
- “S” – This command is sent to the instrument to print the serial number.

The output string needs to be prepended with “7E230250” to obtain the entire S/N

AUTO PRINT MODE

The Auto Print Mode provides a one-time serial transmission once a non-zero, stable condition is achieved.

Output Strings

TEXT PRINT TICKET

The Text Print Ticket is designed specifically for a serial printer.

```
GROSS      1000.0  lb
```

STRING FORMAT 1 (Condec Demand String)

String Format 1 is designed for two-way communication.

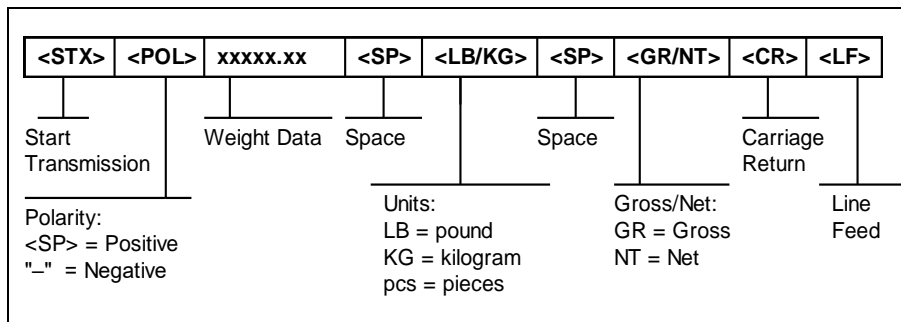



NOTE: Additional unit is available:

- NT = Newtons
- oz = ounce
- g<space> = grams
- lb = pounds
- kg = kilograms

STRING FORMAT 2 (Condec Continuous String)

String Format 1 is designed for one-way communication.

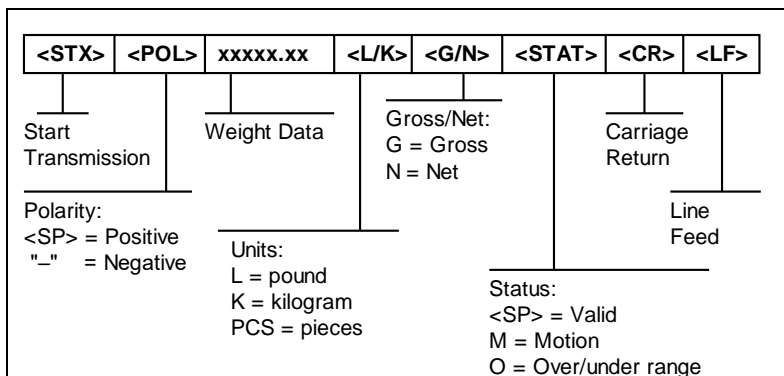

NOTE: Additional unit is available:

- N = Newtons
- O = oz
- G= grams
- L= pounds
- K = grams

Specifications

Instrument Specifications

Enclosure: Aluminum/ABS enclosure (IP54)
Display: 0.8", 6-digit LCD with LED backlight
Upgraded A-to-D converter (AD-02):
Resolution: Up to 4,800,000 Internal Counts @ 4.5 mV/V
Conversion Rate: 75 to 1200 Hz, selectable
Serial Port: Full Duplex RS-232C
Operating temperature: 14°F to 104°F (-10°C to 40°C)

Battery Power

- 4 AA alkaline
- User replaceable
- 85+ continuous hours of operation under typical operating conditions



Error Messages



Err 99

Batteries need to be replaced.

No-ad

Setup menus blocked. Toggle calibration switch back to its original position.

A signal from the load sensor has not been detected

Troubleshooting

Issue / Recommendation

“Low Battery” icon blinks on the digital readout, then the instrument powers off.
Replace the batteries.

Instrument turns off on its own.

The instrument has a power conservation feature, set to automatically power off the instrument after 30 minutes of non-use. If your needs require a different setting, call Morehouse Instrument Company.

Display is erratic or No-Ad message.

- A battery may be fully depleted. If so, this condition can cause erratic displays. Power off the instrument and replace or recharge the battery.
- Check the testing machine load cell for any obstructions or foreign debris
- Loose or faulty connection between the instrument and the load sensor
- Electromagnetic Interference (EMI). Call Morehouse Instrument Company.