

International Workshop on Artificial Intelligence & Internet of Things (A2IoT)  
August 9-12, 2020, Leuven, Belgium

# Edge Computing and Artificial Intelligence for Real-time Poultry Monitoring

Olivier Debauche<sup>a,b,\*</sup>, Saïd Mahmoudi<sup>a</sup>, Sidi Ahmed Mahmoudi<sup>a</sup>, Pierre Manneback<sup>a</sup>,  
Jérôme Bindelle<sup>b,c</sup>, Frédéric Lebeau<sup>b,d</sup>

<sup>a</sup>University of Mons, Faculty of Engineering - ILIA / Infortech, 20 place du Parc, Mons 7000, Belgium

<sup>b</sup>University of Liège - GxABT, TERRA, Passage des déportés 2, Gembloux 5030, Belgium

<sup>c</sup>University of Liège - GxABT, Precision Livestock and Nutrition, Passage des déportés 2, Gembloux 5030, Belgium

<sup>d</sup>University of Liège - GxABT, BioDynE, Passage des déportés 2, Gembloux 5030, Belgium

---

## Abstract

Smart Poultry acquires data from aviaries by means of sensor network at reduced intervals of time (every minute) that generate hundred thousands of data. The conjunction of Internet of Things and Artificial Intelligence open the field of the real-time monitoring of poultry and ,advance analytics and automation if data is from high quality. In this paper, we propose a scalable monitoring of a poultry achieved with open hardware wireless sensors network and software. We use a Gated Recurrent Unit, an artificial intelligence algorithm to validate and predicate environmental parameters.

© 2020 The Authors. Published by Elsevier B.V.

This is an open access article under the CC BY-NC-ND license (<http://creativecommons.org/licenses/by-nc-nd/4.0/>)

Peer-review under responsibility of the Conference Program Chairs.

**Keywords:** Edge AIoT; Edge Computing; Edge Artificial Intelligence; Internet of Things; Artificial Intelligence; Poultry; Smart Poultry; Gated Recurrent Unit; GRU

---

## 1. Introduction

Nowadays, recent advances in Edge Computing, Edge IoT, and Edge AI allow to propose autonomous efficient and intelligent systems. According to Katare et al.[25] combining of AI and IoT are actually used in industries. Nevertheless, the combination between both technologies offers many possibilities in term of advance machine learning and deep learning in order to propose realtime prediction,better analytics, and visualization of data. The merge of AI and IoT provides some capabilities to images and videos processing, object segmentation and tracking, and more advanced automation, etc.

---

\* Corresponding author. Tel.: +32-65-374-059 ; fax: +32-71-140-095.

E-mail address: [olivier.debauche@umons.ac.be](mailto:olivier.debauche@umons.ac.be)

In Poultry Houses, noxious gases such as ammonia ( $\text{NH}_3$ ) are produced by animal metabolism and animal wastes break down. The ammonia production is due to microbial decomposition or reduction of nitrogenous substances, in particular the decomposition of uric acid contained in the litter. The production and the concentration level of  $\text{NH}_3$  depend of multiple factors such as litter type and management, humidity, pH, and temperature. The temperature and humidity must stay respectively in range 13 to 27°C and 50 to 70%. The conjunction of high temperature and humidity promotes the growth of bacterial and consequently the production of ammonia by decomposition of the organic matter [30]. In Poultry, the concentration of ammonia must be maintained between 10 and 25 ppm and not exceed 35 ppm with an exposure type of maximum fifty minutes, the generally adopted limit is 15 ppm. The mean Hydrogen Sulfide cannot exceed 10 ppm and not exceed 15 ppm during maximum fifty minutes. The Threshold Limit Value for Carbon Dioxide concentration ( $\text{CO}_2$ ) is 5,000 ppm and must be normally maintained under 2500 ppm. Other gases are also produced such as Methane ( $\text{CH}_4$ ), Hydrogen Sulfide ( $\text{H}_2\text{S}$ ), Carbon Monoxide ( $\text{CO}$ ).

In this paper, our contribution is the monitoring and the prediction of air quality in poultry by means of Artificial Intelligence algorithm.

## 2. Literature Review

The literature resumes on one hand our background accumulated in previous works and published in diverse papers and on the other hand, a general literature review related works in smart poultry. Some relevant works of other authors are described following three parts. The first part explains the use of Artificial Neural Network and Deep Learning in smart poultry. The second part describes the main contributions to the use of AI in poultry houses. Finally, the third part synthesizes sensors implemented in different papers and afterwards compare them.

### 2.1. Background

In our previous works, we have progressively developed a semantic driven and modular cloud centric Lambda Architecture[18] through various uses cases: landslides monitoring[29], bee health[19], irrigation [5], elderly and patient monitoring[13], AI-IoT[9], smart campus[4], smart home[8], smart city[10], smart building[16], cattle behavior[7][15][6][11], phenotyping[14][17], urban gardening[2], climatic enclosure[12], smart bird[1].

In this paper, we develop the edge level which collaborate with our previously developed cloud architecture in order to deploy micro services and artificial intelligence algorithms to analyze, validate, curate, compress data.

### 2.2. Related Works

Diverse authors have diversely applied artificial intelligence, edge computing, wireless sensor network, and Internet of Things on smart poultry. We describe some of their contributions in the following paragraphs.

#### 2.2.1. Artificial Intelligence and poultry

Artificial Neural Networks has been applied to smart poultry to (1) determine accurate action plans for poultry management using ANNs of 4 layers with multiple output regression neurons from a set of data acquired through a sensor network and external data such as the meteorological data, bibliography material, etc. in [33]; (2) to predict moisture contained in poultry litter moisture in [34]; (3) to determine slaughter weight of chicken with an ANN with an input layer of 7 neurons, 11 neurons in the hidden layer and one neuron in the output layer in [24].

#### 2.2.2. Edge computing solution for smart poultry

Yang et al. in 2019 [37] proposed an Edge Computing solution to monitor chicken house. Temperature, humidity and light intensity are measured and transmitted by end nodes to the gateway with ZigBee network. At the edge level data is processed and is used on hand to control the light intensity and fan and on the other hand is uploaded to the cloud.

Table 1: Synthesis of Literature review

Author	Micro computer	Micro controller	Connectivity	Temperature	Humidity	Air quality	Other
Raj et al.,2018 [32]	local computer	Arduino UNO	USB	DHT22	DHT22	MQ137	RGB camera, LV-MaxSonar-EZI
Goud et al., 2015 [21]	ARM Cortex M4	Arduino UNO	Wi-Fi	LM35	HH4030	-	HC-SR04
Handigolkar et al., 2016 [22]	Raspberry Pi 2	Arduino UNO	UART	DHT11	DHT11	MQ2, MQ135, MQ136	LDR
Fangu et al., 2009 [20]	-	CC2430	Zigbee	SHT75	SHT75	TGS4161	-
Wang et al., 2015 [26]	-	CC2430	Wireless	DHT22	DHT22	-	-
So-In et al., 2014 [36]	-	Arduino Mega ADK	-	DHT22	DHT22	-	ZX-LDR
Mahale et al.,2016a [28]	Raspberry Pi 2	Arduino UNO	UART	DHT11	-	MQ2, MQ135, MQ136	LDR
Mahale et al., 2016b [27]	-	ATMEGA324A	GPRS	LM35	SY-HS-220	MQ135	level sensor
Islam et al., 2019 [23]	-	Arduino UNO	GSM/WiFi	DHT11	DHT11	MQ5, MQ7	LDR, Hall Effect sensor
Sitaram et al., 2018 [35]	ESP8266 WiFi	Arduino UNO	GPRS	DHT11	DHT11	MQ135	DS3231, LDR, IR sensor
Choukidar et al., 2017 [3]	Raspberry Pi	-	GPRS	LM35	SY-HS-220	MQ135	Smoke Sensor
Raghudathesh et al., 2017 [31]	Raspberry Pi 3	Arduino UNO	GPRS	DHT11	DHT11	MQ6	LDR, USB Camera
Othman et al., 2014 [30]	-	Zelio logic SR3B101BD	Pt100-6S-SLK	HX71-V1	SMS	KB-501	-
Yang et al., 2019 [37]	STM32	CC2530	Zigbee	DHT11	DHT11	-	BH1750FVI

Table 2: Comparison of sensors

Sensor	Manufacture	Type	Voltage	Range	Accuracy
LM35	Texas Instruments	Temperature	4V to 30V	-55°C to 150°C	±0.5°C
Pt100-6S-SLK	Gemo	Temperature	?	-50° to 200°	?
HX71-V1	-	Relative Humidity	5	0% to 100%	±3.5%
SY-HS-220	SYHITECH	Relative Humidity	5V	30% to 90%	±5%
HH4030	Honeywell	Relative Humidity	4 to 5.8V	0% to 100%	±3.5%
DHT11	Aosong	Temperature / Relative Humidity	3 to 5V	0°C to 50°C / 20% to 80%	±2°C / ±5%
DHT22	Aosong	Temperature / Humidity	3 to 5V	-40°C to 150°C / 0% to 100%	±0.5°C / ±2%
SHT75	Sensirion	Temperature / Humidity	2.4V to 5.5V	-40°C to 123.8°C / 0% to 100%	±0.3°C / ±1.8%
MQ2	Hanwei Sensors	Methane, Butane, LPG, Smoke	5V	200ppm to 10,000ppm	α ≤ 0.6
MQ5	Hanwei Sensors	Natural gas, LNG, LPG, iso-butane, propane, Town gas	5V	200ppm to 10,000ppm	α ≤ 0.6
MQ6	Hanwei Sensors	LPG, butane	5V	200ppm to 10,000ppm	α ≤ 0.6
MQ7	Hanwei Sensors	Carbon Monoxide	5V	10ppm to 10,000ppm	α ≤ 0.6
MQ135	Hanwei Sensors	Air Quality	5V	10ppm to 300ppm NH <sub>3</sub>	α ≤ 0.65
MQ136	Hanwei Sensors	Hydrogen Sulphide gas	5V	1ppm to 100ppm H <sub>2</sub> S	α ≤ 0.65
MQ137	Hanwei Sensors	Ammonia	5V	1ppm to 200ppm	α ≤ 0.65
KB-501	Zhengzhou Kesa Electronics	Gas detector	16 to 30V	0ppm to 100ppm	±5%
TGS4161	Figaro	Carbon Dioxide	5V	350ppm to 10,000ppm	±20%
HC-SR04	Cytron Technologies	Water Level	5V	2cm to 400 cm	0.3 cm

### 2.2.3. Internet of Things in poultry

Several authors have proposed divers Smart poultry solutions based on quality sensors, air temperature, and relative humidity sensors. Air quality sensors which have been chosen are often inadequate for the environmental parameters acquisition in an industrial poultry. Indeed, crucial parameters that must be monitored in a poultry are concentration in Ammonia ( $\text{NH}_3$ ), Hydrogen Sulfide ( $\text{H}_2$ ), Carbon Dioxide ( $\text{CO}_2$ ), and Dioxygen ( $\text{O}_2$ ). Methane and Nitrogen Dioxide are also produced but rarely monitored. A synthesis of sensors used by different authors is done in Table 1. Technical characteristics are then compared in the Table 2.

The analyze of the literature shows that the different authors implemented temperature, relative humidity sensors. Temperature sensors most often used are LM35 [21][3], DHT11 [22][28][23][35][31][37], and DHT22 [32][26][36] while Humidity sensors most frequently used are DHT11 [22][23][35][31][37], DHT22 [32][26][36], SY-HS-220 [27][3].

Raj et al. [32] used a MQ137 gas sensor to measures uniquely ammonia concentration in the air. While other authors use non specific gas sensors i.e: MQ135 to measures  $\text{NH}_3$  air concentration. Handigolkar et al. [28] implemented MQ136, another kind of gas sensor to measure Hydrogen Sulfide ( $\text{H}_2\text{S}$ ) in the air.

## 3. Material and Method

Our proposition is built around a micro computer and a Wireless Sensors Network which allows to acquire environmental data which are then processed at the edge level of the network.



Fig. 1: Micro computer & Microcontroller

### 3.1. Micro computer

NVIDIA Jetson Nano (472 GFLOPS) is a micro computer equipped of 128-core CUDA Maxwell which allows to train and exploit Artificial Intelligence algorithms. The Jetson Nano contains also a Quad-core ARM A57@1.43 GHz, 4GB 64-bit LPDDR4@25.6 GB/s (Fig. 1a).

### 3.2. Microcontroller

The ESP32-Wroom-32 is equipped with a Wi-Fi and a Bluetooth interfaces that allows it to communicate with the local gateway configured as Access Point. We use Arduino IDE to program it in the same way as an Arduino UNO. ESP-WROOM-32 contains a Xtensa dual-core 32-bit LX6 microprocessor at 240 MHz, 520 KiB SRAM, 4 MiB Flash Memory. Moreover it provides 12-bit SAR ADC up to 18 channels, 2 DAC of 8-bit, 10 GPIO, 4 Serial Peripheral Interface (SPI), 2 Inter-IC Sound ( $I^2S$ ), 2 Inter-integrated Circuit ( $I^2C$ ). It is used to connect sensors inside buildings (Fig. 1b).

### 3.3. Sensors

The MQ4 is a digital sensor measuring Methane ( $\text{CH}_4$ ) concentration between 200ppm and 10000ppm. The MQ7 is a digital sensor which evaluate the Carbon Monoxide (CO) concentration in a range of 20ppm to 2000ppm. The MQ136 is a long life and reliable stability digital sensor which detects the Hydrogen Sulfide ( $\text{H}_2\text{S}$ ) in range of 1 to 200 ppm. Its current consumption is 150mA with an operating voltage of DC 5V. The MQ137 digital sensor measures ammonia ( $\text{NH}_3$ ) concentration comprised between 5 to 500 ppm. The MG811 carbon dioxide sensors. The DS3231 is a low-cost, and extremely accurate  $I^2C$  real-time clock (RTC) with an integrated temperature-compensated crystal oscillator (TCXO). The temperature and Humidity  $I^2C$  sensor used is AM2315 (Aosong) able to acquire the temperature in a range of  $-40$  to  $85^\circ\text{C}$  with a precision of  $\pm 0.5^\circ\text{C}$ . The HC-SR04 is digital ultrasonic sensors able to measure distance between 2 and 400 cm with an accuracy of 3 mm in optimal condition. The sensors emits a sonar wave composed of 8 pulses at 40 kHz. We use it to measure the water level in the tank. The HX711 is a 24-Bit Analog-to-Digital Converter (ADC) for Load Cell. The TSL2591 (Adafruit Industries LLC) is a high dynamic range digital light sensor using  $I^2C$  bus which can detect light ranges from up to  $188 \mu\text{Lux}$  up to 88,000 Lux.

### 3.4. Implementation

Our system is composed of an NVIDIA Jetson Nano, several environmental sensor nodes, a Nutrition Nodes all interconnected by means of a Wi-Fi gateway.

*Environment Sensing Node.* is based on an esp32s and equipped with following sensors to measure the rate of crucial gas concentration in the air of : methane with the MQ4 sensor, ammonia with the MQ137, carbon monoxide with MQ7, carbon dioxide with MG811 sensor. In addition, this node is also equipped with a temperature and humidity sensor, a real-time clock to timestamp data and a light intensity sensor. The microcontroller with all these sensors measure regularly ambient condition of the poultry. This kind sensor of node is suspended from the ceiling of the building and transmit its data by Wi-Fi. The (Fig. 2a) shows a block diagram of the environment sensing node.

*Nutrition Sensor Node.* is built around of an esp32s, a real-time clock to timestamp data, a water level sensor to measure the availability of water for chicken, and a load cell with its 24-bit ADC convertor measures the amount of food available in animal feeders (Fig. 2b). This kind of node is placed near the ground. The esp32s transmit regularly data by Wi-Fi to the gateway.

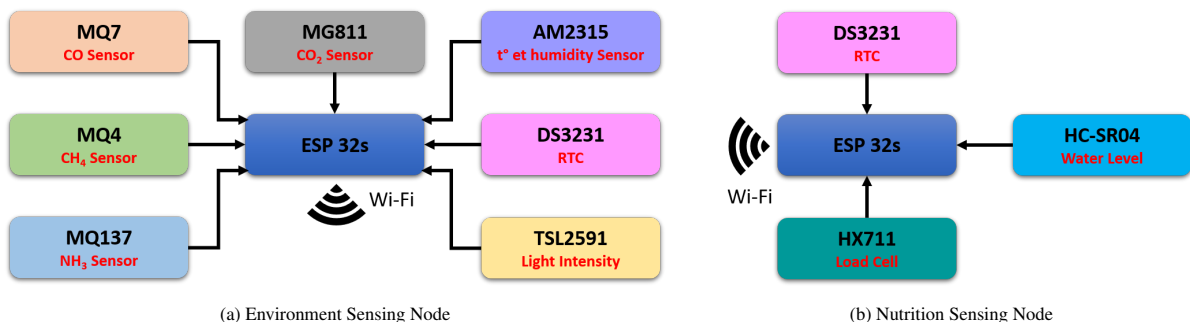

Fig. 2: Block Diagram

## 4. Experimentation

Our experimentation uses a three environmental nodes and two Nutrition Sensing Node connected to a TP-Link Archer C50 WiFi router offering a theoretical bandwidth of 1200 Mbps: 300 Mbps in 2.4 GHz and 867 Mbps in 5 GHz. Environmental Node send data each 5 minutes and Nutrition Sensing Nodes transmit then each 5 minutes to the micro computer. The Jetpack 4.3 is installed on the Jetson Nano SD Card. It contains the L4T 32.3.1 OS, TensorRT

6.0.1, cuDNN 7.6.3, CUDA 1.0.326 and OpenCV 4.1.1.

We have implemented a Gated Recurrent Unit (GRU) Which is a simplified Long Short-Term Memory cells (LSTM) combining the cell state and hidden state together. These improvements allow to speed up both the training and the prediction phase while avoiding the vanishing gradient problem from which the Recurrent Neural Network (RNN) suffers. Our database contains poultry environmental data received every 5 minutes.

GRU layer of  $M$  neurons and  $N$  dimensional input is described by following equations:

$$\begin{aligned}
 r_t &= \sigma(W_{ir}x_t + W_{hr}h_{t-1} + b_r) \\
 u_t &= \sigma(W_{iu}x_t + W_{hu}h_{t-1} + b_u) \\
 c_t &= \tanh(W_{ic}x_t + r_t \odot (W_{hc}h_{t-1}) + b_c) \\
 h_t &= (1 - u_t) \odot c_t + u_t \odot h_{t-1}
 \end{aligned} \tag{1}$$

Where  $r$ ,  $u$ ,  $c \in \mathcal{R}^M$  are respectively the reset gate, the update gate and the cell state.  $W_i \in \mathcal{R}^{M \times N}$ ,  $W_h \in \mathcal{R}^{M \times M}$  are weight matrices and  $b \in \mathcal{R}^M$  are bias vectors.  $\sigma$  denotes the logistic sigmoid.

## 5. Results and discussion

The Figure 3 shows in blue the measurement of ammonia rate in ppm and in red the estimation obtained with the GRU algorithm.

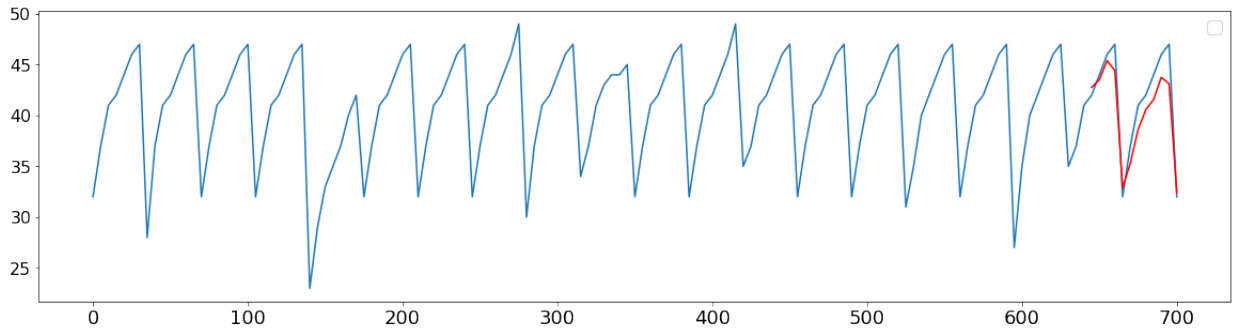

Fig. 3: Prediction of data based on GRU algorithm

The GRU algorithm is used on one hand to verify the data quality received from Environment Sensing Node and Nutrition Sensing Node and to predict evolution of data in the near future. By comparison to predict value and the measure value, it is possible to deduce if a sensor is failed or an anomaly data is produced.

GRU are simpler than LSTM and by consequence easier to modify. Moreover, GRU train faster and the performance is on LSTM. These latter are utilizing different way if gating information to prevent vanishing gradient problem. The GRU controls the flow of information like the LSTM unit, but without having to use a memory unit. It just exposes the full hidden content without any control.

## 6. Conclusion and Future Works

In this paper, we propose an edge computing and Artificial Intelligence architecture for smart poultry which exploit new possibilities offered by Nvidia Jetson Nano to analyze, validate and aggregate sensors data coming from

Environment Sensing Node and Nutrition Sensing Node. Jetson Nano also allows to process video and photo taken with an USB HD webcam. In future works, we will implement video treatment and animal chicken analysis to detect anomaly in the poultry such as abnormal mortality, stress, and viz.

## Acknowledgements

The authors would like to express their gratitude to Mrs Meryem El Moulat for English editing of this paper.

## References

- [1] Ait abdelouahid, R., Debauche, O., Mahmoudi, S., Abdelaziz, M., Manneback, P., Lebeau, F., 2020. Smart nest box: IoT based nest monitoring in artificial cavities, in: 2020 3rd International Conference on Advanced Communication Technologies and Networking (CommNet) (CommNet'20), , Morocco.
- [2] Ait Abdelouahid, R., Debauche, O., Mahmoudi, S., Marzak, A., Manneback, P., Lebeau, F., 2020. Open phytotron: A new iot device for home gardening, in: 2020 5th International Conference on Cloud Computing Technologies and Applications (Cloudtech), pp. 1–7.
- [3] Choukidar, G.A., Dawande, N., 2017. Smart poultry farm automation and monitoring system, in: 2017 International Conference on Computing, Communication, Control and Automation (ICCUBEA), IEEE. pp. 1–5.
- [4] Debauche, O., Ait abdelouahid, R., Mahmoudi, S., Moussaoui, Y., Abdelaziz, M., Manneback, P., 2020a. Revo campus: a distributed open source and low-cost smart campus, in: 2020 3rd International Conference on Advanced Communication Technologies and Networking (CommNet) (CommNet'20), , Morocco.
- [5] Debauche, O., El Moulat, M., Mahmoudi, S., Manneback, P., Lebeau, F., 2018. Irrigation pivot-center connected at low cost for the reduction of crop water requirements, in: 2018 International Conference on Advanced Communication Technologies and Networking (CommNet), pp. 1–9. doi:[10.1109/COMMNET.2018.8360259](https://doi.org/10.1109/COMMNET.2018.8360259).
- [6] Debauche, O., Mahmoudi, S., Andriamandroso, A., Manneback, P., Bindelle, J., Lebeau, F., 2018. Cloud services integration for farm animals' behavior studies based on smartphones as activity sensors. Journal of Ambient Intelligence and Humanized Computing URL: <https://doi.org/10.1007/s12652-018-0845-9>, doi:[10.1007/s12652-018-0845-9](https://doi.org/10.1007/s12652-018-0845-9).
- [7] Debauche, O., Mahmoudi, S., Andriamandroso, A., P., M., J., B., Lebeau, F., 2017. Web-based cattle behavior service for researchers based on the smartphone inertial central. Procedia Computer Science 110, 110 – 116. URL: <http://www.sciencedirect.com/science/article/pii/S1877050917313066>, doi:<https://doi.org/10.1016/j.procs.2017.06.127>. 14th International Conference on Mobile Systems and Pervasive Computing (MobiSPC 2017) / 12th International Conference on Future Networks and Communications (FNC 2017) / Affiliated Workshops.
- [8] Debauche, O., Mahmoudi, S., Belarbi, M.A., El Adoui, M., Mahmoudi, S.A., 2018a. Internet of things: Learning and practices. application to smart home, in: 2018 International Conference on Advanced Communication Technologies and Networking (CommNet), pp. 1–6. doi:[10.1109/COMMNET.2018.8360247](https://doi.org/10.1109/COMMNET.2018.8360247).
- [9] Debauche, O., Mahmoudi, S., Doukha, R., Mahmoudi, S.A., Manneback, P., Lebeau, F., 2020b. A new edge architecture for ai-iot services deployment. Procedia Computer Science The 17th International Conference on Mobile Systems and Pervasive Computing (MobiSPC) / The 15th International Conference on Future Networks and Communications (FNC 2020) / Affiliated Workshops.
- [10] Debauche, O., Mahmoudi, S., Mahmoudi, S.A., 2018b. Internet of things: learning and practices. application to smart city, in: 2018 4th International Conference on Cloud Computing Technologies and Applications (Cloudtech), pp. 1–7. doi:[10.1109/CloudTech.2018.8713337](https://doi.org/10.1109/CloudTech.2018.8713337).
- [11] Debauche, O., Mahmoudi, S., Mahmoudi, S.A., Manneback, P., Bindelle, J., Lebeau, F., 2020c. Edge computing for cattle behavior analysis, in: 2020 Second international conference on Embedded Distributed Systems (EDiS), pp. 1–5.
- [12] Debauche, O., Mahmoudi, S., Mahmoudi, S.A., Manneback, P., Lebeau, F., 2020d. Edge computing and artificial intelligence semantically driven. application to a climatic enclosure. Procedia Computer Science The 17th International Conference on Mobile Systems and Pervasive Computing (MobiSPC) / The 15th International Conference on Future Networks and Communications (FNC 2020) / Affiliated Workshops.
- [13] Debauche, O., Mahmoudi, S., Manneback, P., Assila, A., 2019. Fog iot for health: A new architecture for patients and elderly monitoring. Procedia Computer Science 160, 289 – 297. URL: <http://www.sciencedirect.com/science/article/pii/S1877050919317880>, doi:<https://doi.org/10.1016/j.procs.2019.11.087>. the 10th International Conference on Emerging Ubiquitous Systems and Pervasive Networks (EUSPN-2019) / The 9th International Conference on Current and Future Trends of Information and Communication Technologies in Healthcare (ICTH-2019) / Affiliated Workshops.
- [14] Debauche, O., Mahmoudi, S., Manneback, P., Massinon, M., Tadriss, N., Lebeau, F., Mahmoudi, S.A., 2017. Cloud architecture for digital phenotyping and automation, in: 2017 3rd International Conference of Cloud Computing Technologies and Applications (CloudTech), pp. 1–9. doi:[10.1109/CloudTech.2017.8284718](https://doi.org/10.1109/CloudTech.2017.8284718).
- [15] Debauche, O., Mahmoudi, S., Manneback, P., Tadriss, N., Bindelle, J., Lebeau, F., 2017. Improvement of battery life of iphones inertial measurement unit by using edge computing application to cattle behavior, in: 2017 Symposium International sur les Sciences Informatiques et Applications (ISCSA2017), pp. 1–4.
- [16] Debauche, O., Mahmoudi, S., Moussaoui, Y., 2020. Internet of things learning: a practical case for smart building automation, in: 2020 5th International Conference on Cloud Computing Technologies and Applications (Cloudtech), pp. 1–7.
- [17] Debauche, O., Mahmoudi, S.A., De Cock, N., Mahmoudi, S., Manneback, P., Lebeau, F., 2020. Cloud architecture for plant phenotyping research. Concurrency and Computation: Practice and Experience n/a, e5661. URL: <https://onlinelibrary.wiley.com/doi/abs/>

- 10.1002/cpe.5661, doi:10.1002/cpe.5661, arXiv:<https://onlinelibrary.wiley.com/doi/pdf/10.1002/cpe.5661>. e5661 cpe.5661.
- [18] Debauche, O., Mahmoudi, S.A., Mahmoudi, S., Manneback, P., 2018a. Cloud platform using big data and hpc technologies for distributed and parallels treatments. *Procedia Computer Science* 141, 112–118.
- [19] Debauche, O., Moulat, M.E., Mahmoudi, S., Boukraa, S., Manneback, P., Lebeau, F., 2018b. Web monitoring of bee health for researchers and beekeepers based on the internet of things. *Procedia Computer Science* 130, 991 – 998. URL: <http://www.sciencedirect.com/science/article/pii/S1877050918304654>, doi:<https://doi.org/10.1016/j.procs.2018.04.103>. the 9th International Conference on Ambient Systems, Networks and Technologies (ANT 2018) / The 8th International Conference on Sustainable Energy Information Technology (SEIT-2018) / Affiliated Workshops.
- [20] Dong, F., Zhang, N., 2009. Wireless sensor networks applied on environmental monitoring in fowl farm, in: *International Conference on Computer and Computing Technologies in Agriculture*, Springer. pp. 479–486.
- [21] Goud, K.S., Sudharson, A., 2015. Internet based smart poultry farm. *Indian Journal of Science and Technology* 8, 1.
- [22] Handigolkar, L.S., Kavya, M., Veena, P., 2016. Iot based smart poultry farming using commodity hardware and software. *Bonfring International Journal of Software Engineering and Soft Computing* 6, 171–175.
- [23] Islam, M.M., Tonmoy, S.S., Quayum, S., Sarker, A.R., Hani, S.U., Mannan, M.A., 2019. Smart poultry farm incorporating gsm and iot, in: *2019 International Conference on Robotics, Electrical and Signal Processing Techniques (ICREST)*, IEEE. pp. 277–280.
- [24] Jahan, M., Maghsoudi, A., Rokouei, M., Faraji-Arough, H., 2019. Prediction and optimization of slaughter weight in meat-type quails using artificial neural network modeling. *Poultry Science* .
- [25] Katare, G., Padihar, G., Qureshi, Z., . Challenges in the integration of artificial intelligence and internet of things. *International Journal of Systems and Software Engineering* 6, 10–15.
- [26] Li, H., Wang, H., Yin, W., Li, Y., Qian, Y., Hu, F., 2015. Development of a remote monitoring system for henhouse environment based on iot technology. *Future Internet* 7, 329–341. URL: <https://www.mdpi.com/1999-5903/7/3/329>, doi:10.3390/fi7030329.
- [27] Mahale, R.B., Sonavane, S., 2016a. Smart poultry farm: An integrated solution using wsn and gprs based network. *International Journal of Advanced Research in Computer Engineering & Technology (IJARCET)* Volume 5.
- [28] Mahale, R.B., Sonavane, S., 2016b. Smart poultry farm monitoring using iot and wireless sensor networks. *International Journal of Advanced Research in Computer Science* 7, 187–190.
- [29] Moulat, M.E., Debauche, O., Mahmoudi, S., Brahim, L.A., Manneback, P., Lebeau, F., 2018. Monitoring system using internet of things for potential landslides. *Procedia Computer Science* 134, 26 – 34. URL: <http://www.sciencedirect.com/science/article/pii/S1877050918311037>, doi:<https://doi.org/10.1016/j.procs.2018.07.140>. the 15th International Conference on Mobile Systems and Pervasive Computing (MobiSPC 2018) / The 13th International Conference on Future Networks and Communications (FNC-2018) / Affiliated Workshops.
- [30] Othman, J.K., Mahmood, J.R., et al., 2014. Design and implementation of smart relay based remote monitoring and controlling of ammonia in poultry houses. *International Journal of Computer Applications* 103.
- [31] Raghudathesh, G., Deepak, D., Prasad, G.K., Arun, A., Balekai, R., Yatnalli, V.C., Lata, S., Kumar, B.S., 2017. Iot based intelligent poultry management system using linux embedded system, in: *2017 International Conference on Advances in Computing, Communications and Informatics (ICACCI)*, IEEE. pp. 449–454.
- [32] Raj, A.A.G., Jayanthi, J.G., 2018. Iot-based real-time poultry monitoring and health status identification, in: *2018 11th International Symposium on Mechatronics and its Applications (ISMA)*, pp. 1–7. doi:10.1109/ISMA.2018.8330139.
- [33] Ribeiro, R., Casanova, D., Teixeira, M., Wirth, A., Gomes, H.M., Borges, A.P., Enembreck, F., 2019. Generating action plans for poultry management using artificial neural networks. *Computers and Electronics in Agriculture* 161, 131–140.
- [34] Rico-Contreras, J.O., Aguilar-Lasserre, A.A., Méndez-Contreras, J.M., López-Andrés, J.J., Cid-Chama, G., 2017. Moisture content prediction in poultry litter using artificial intelligence techniques and monte carlo simulation to determine the economic yield from energy use. *Journal of Environmental Management* 202, 254 – 267. URL: <http://www.sciencedirect.com/science/article/pii/S0301479717307119>, doi:<https://doi.org/10.1016/j.jenvman.2017.07.034>.
- [35] Sitaram, K.A., Ankush, K.R., Anant, K.N., Raghunath, B.R., 2018. Iot based smart management of poultry farm and electricity generation, in: *2018 IEEE International Conference on Computational Intelligence and Computing Research (ICIC)*, IEEE. pp. 1–4.
- [36] So-In, C., Poolsanguan, S., Rujirakul, K., 2014. A hybrid mobile environmental and population density management system for smart poultry farms. *Computers and Electronics in Agriculture* 109, 287 – 301. URL: <http://www.sciencedirect.com/science/article/pii/S0168169914002518>, doi:<https://doi.org/10.1016/j.compag.2014.10.004>.
- [37] Yang, X., Zhang, F., Jiang, T., Yang, D., 2019. Environmental monitoring of chicken house based on edge computing in internet of things, in: *2019 IEEE 8th Joint International Information Technology and Artificial Intelligence Conference (ITAIC)*, IEEE. pp. 617–620.