

# B22 XXII INTERNATIONAL CONFERENCE ON FEW-BODY PROBLEMS IN PHYSICS

9-13 JULY 2018 - Caen, France



<http://fb22-caen.sciencesconf.org>

## Topics

- Atomic and molecular physics
- Hadron physics and related high energy physics
- Strange and exotic matter, including hypernuclear physics
- Few-nucleon systems
- Few-body aspects of nuclear physics and nuclear astrophysics
- Interdisciplinary aspects of few-body physics and techniques

## LOCAL ORGANISING COMMITTEE

Nigel Orr (LPC-Caen) – Chair  
Jaume Carbonell (IPN-Orsay) – Chair International Advisory Committee  
Marek Płoszajczak (GANIL, Caen) – Chair Scientific Programme Committee  
Lynda Achouri (LPC-Caen)  
Amine Cassimi (CIMAP, Caen)  
Mario Gattobigio (INPHYNI, Nice)  
Paul-Antoine Hervieux (IPCM, Strasbourg)  
Ubirajara van Kolck (IPN-Orsay)  
Rimantas Lazauskas (IPHC, Strasbourg)  
Hervé Moutarde (IRFU, CEA-Saclay)  
Miguel Marqués (LPC-Caen) – Scientific Secretary  
Jean-Marc Richard (IPN-Lyon)

flashcode

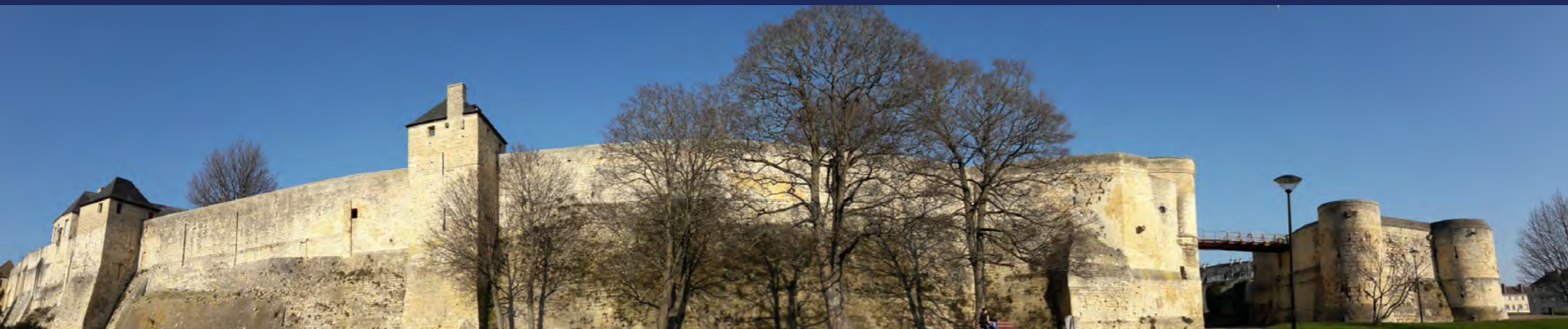

# Hirschegg 2018

## Multiparticle resonances in hadrons, nuclei, and ultracold gases

International Workshop XLVI on Gross Properties of Nuclei and Nuclear Excitations

January 14-20, 2018, Hirschegg (Austria)

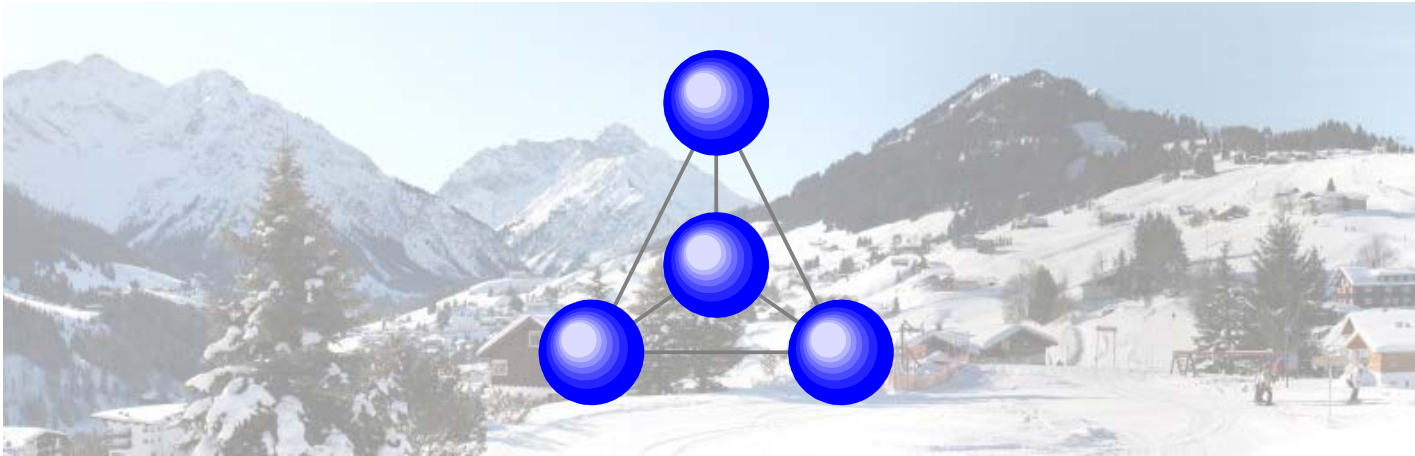

## Tetra-neutron : the experimental context

F. Miguel Marqués



## ① The $A_n$ context :

- XX century :  $\sigma(A_n)$  & backgrounds ...
- XXI century : first signals !
  - GANIL : theory & experiments
  - RIKEN : more candidate events
- experimental constraints
- theoretical 'proofs' ?

## ② The RIKEN campaign :

- SHARAQ 2.0 :  ${}^4\text{He}({}^8\text{He}, \alpha\alpha){}^4\text{n}$
- NEBULA+NeuLAND & MINOS :
  - ${}^8\text{He}(p, p\alpha){}^4\text{n}$  : 4n without FSI
  - ${}^8\text{He}(p, 2p)\{{}^3\text{H}+{}^4\text{n}\}$  : any  $(E, \Gamma)_R$

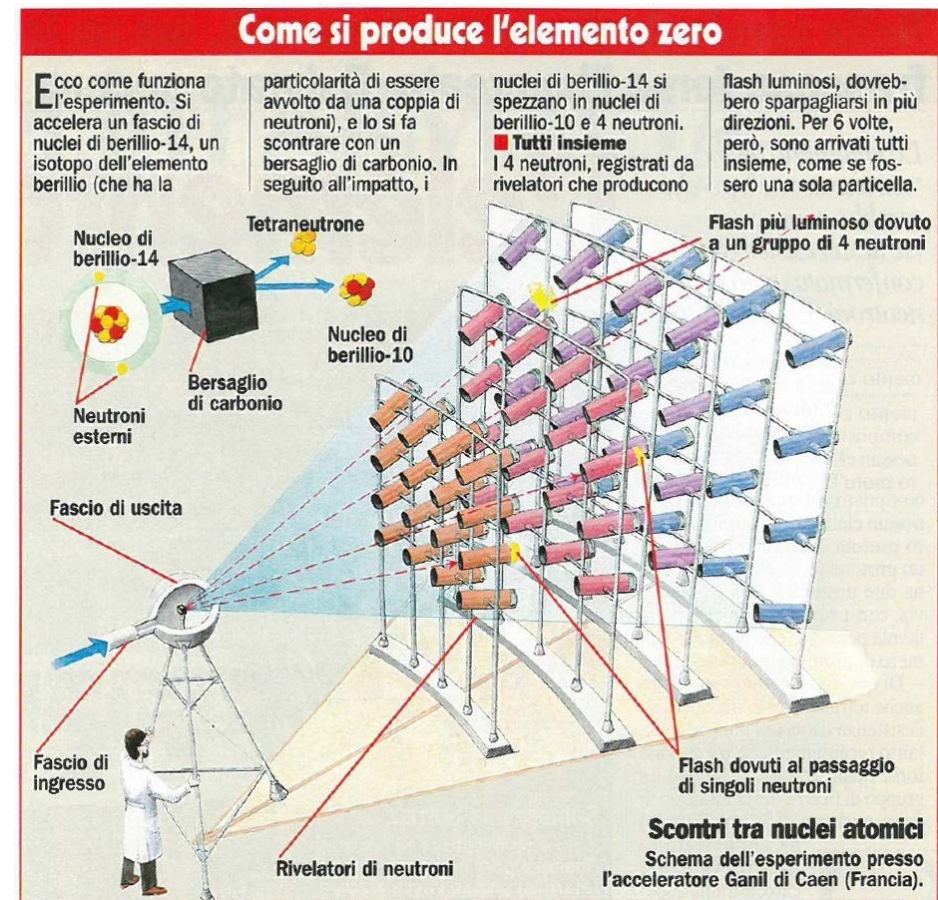



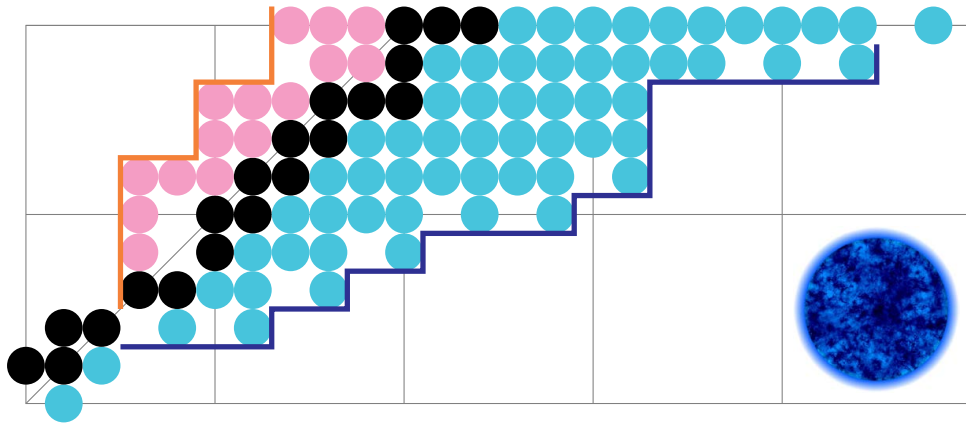

► Well-established facts :

- $N = 2$  (✗) ...  $10^{57}$  (✓)
- the 'multi-neutron anomaly' :

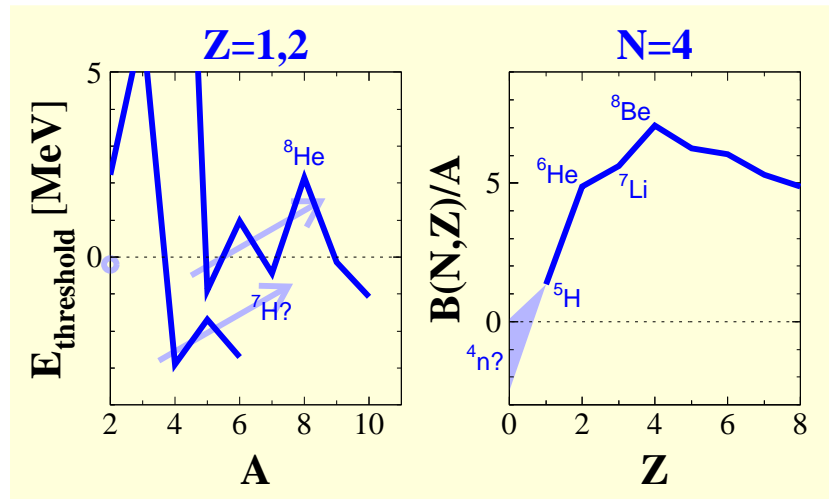

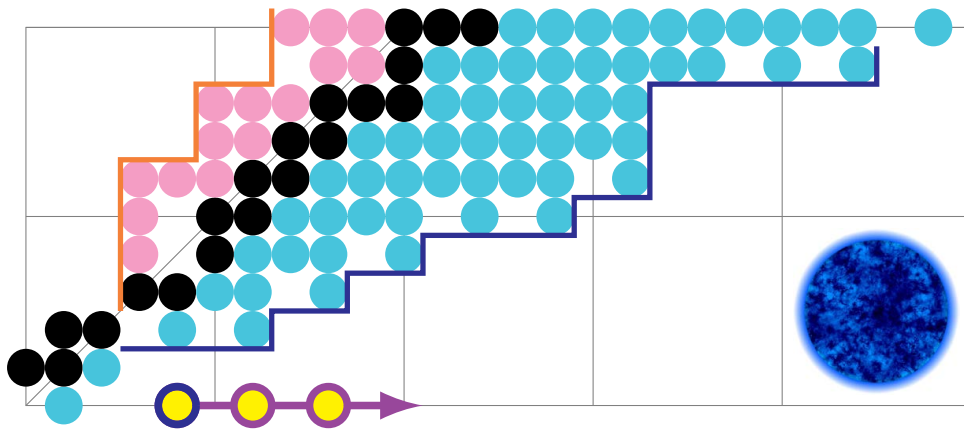

► Candidate systems ?

- odd-even staggering : even N
- hard to put many neutrons together !

→ **N = 4**

► Well-established facts :

- $N = 2$  (✗) ...  $10^{57}$  (✓)
- the 'multi-neutron anomaly' :

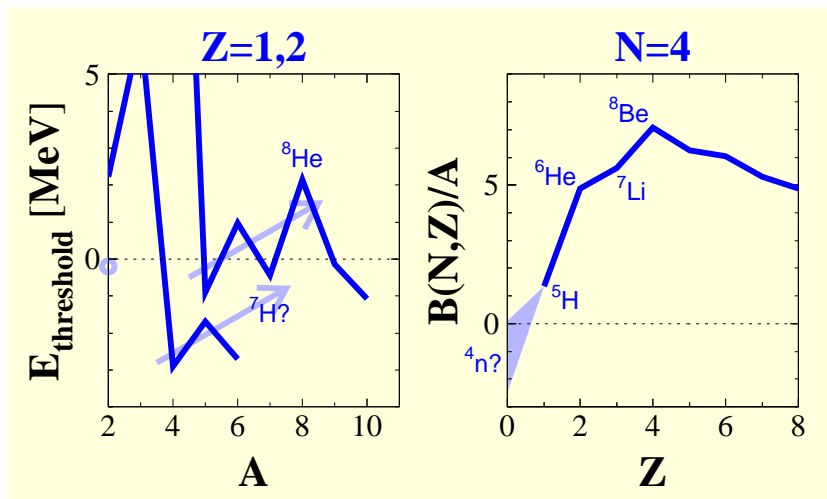

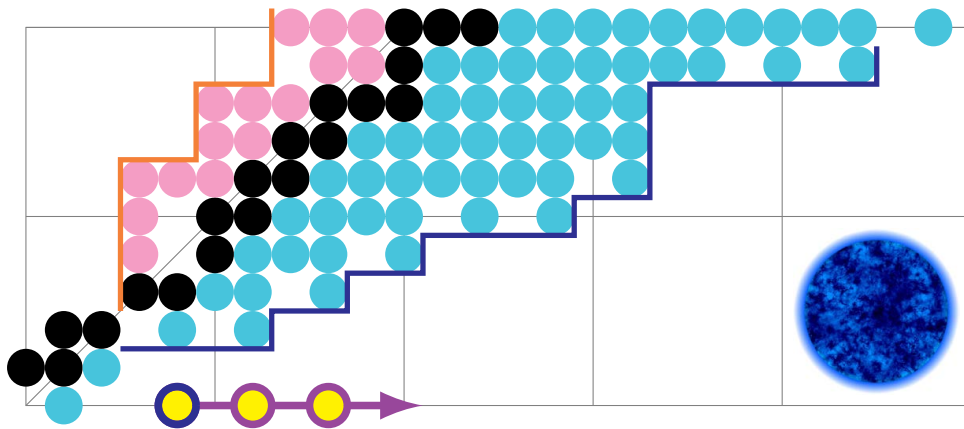

▶ Well-established facts :

- $N = 2$  (✗) ...  $10^{57}$  (✓)
- the 'multi-neutron anomaly' :

▶ Candidate systems ?

- odd-even staggering : even  $N$
  - hard to put many neutrons together !
- $N = 4$

▶ Biggest issues :

- production of a too n-rich system ...
- detection of a neutral object ...

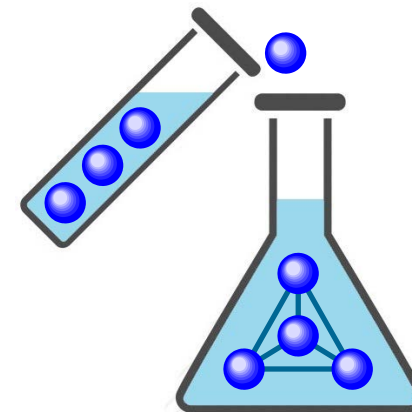
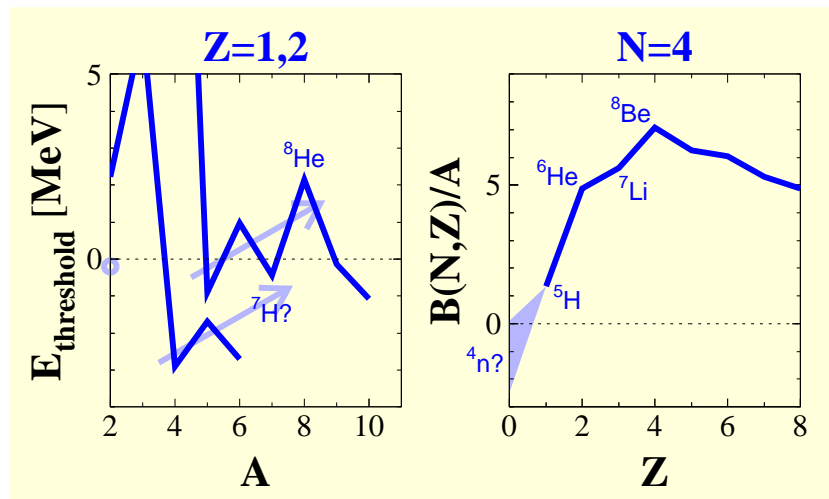

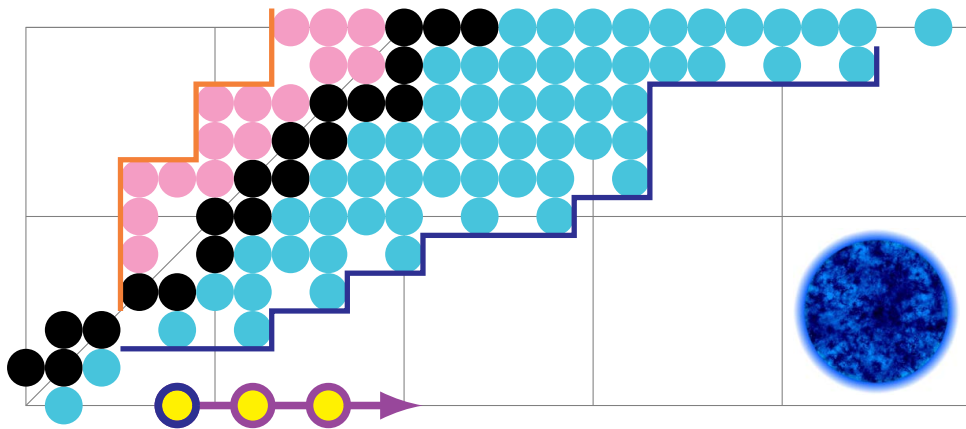

▶ Well-established facts :

- $N = 2$  (✗) ...  $10^{57}$  (✓)
- the 'multi-neutron anomaly' :

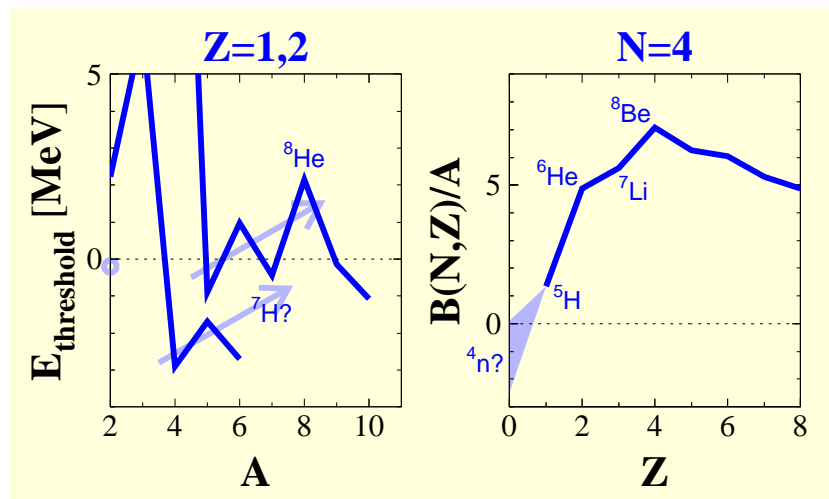

▶ Candidate systems ?

- odd-even staggering : even N
  - hard to put many neutrons together !
- **N = 4**

▶ Biggest issues :

- **production** of a too n-rich system ...
- **detection** of a neutral object ...

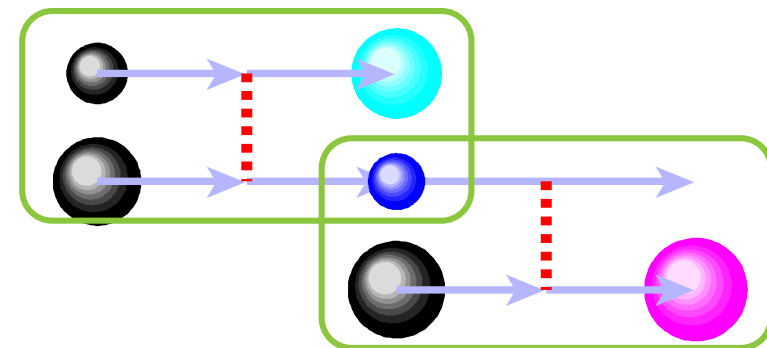

→ XX century :  **$\sigma(A_n)$**  & **backgrounds** ...



## Come si produce l'elemento zero

Ecco come funziona l'esperimento. Si accelera un fascio di nuclei di berillio-14, un isotopo dell'elemento berillio (che ha la

particolarità di essere avvolto da una coppia di neutroni), e lo si fa scontrare con un bersaglio di carbonio. In seguito all'impatto, i

nuclei di berillio-14 si spezzano in nuclei di berillio-10 e 4 neutroni. **Tutti insieme** I 4 neutroni, registrati da rivelatori che producono

flash luminosi, dovrebbero sparpagliarsi in più direzioni. Per 6 volte, però, sono arrivati tutti insieme, come se fossero una sola particella.

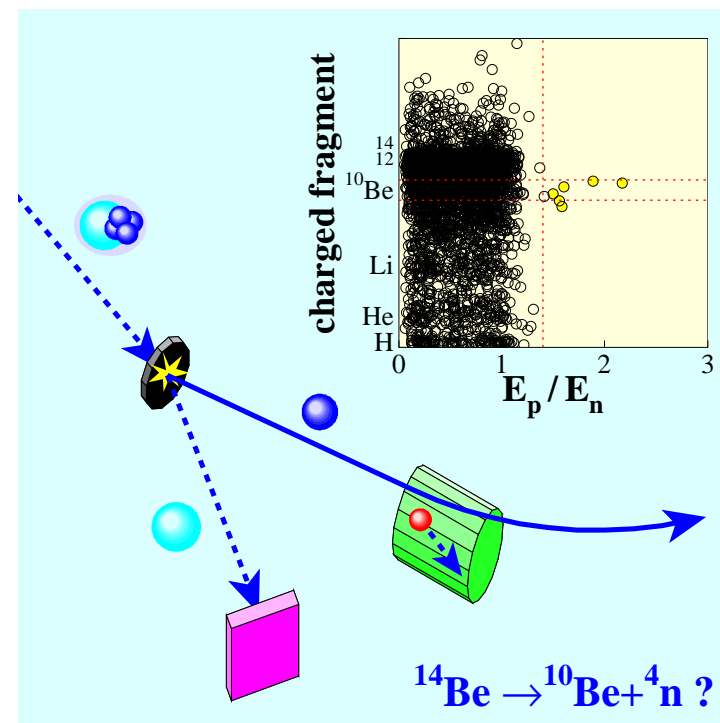
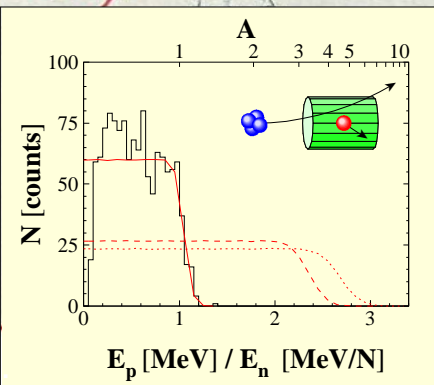
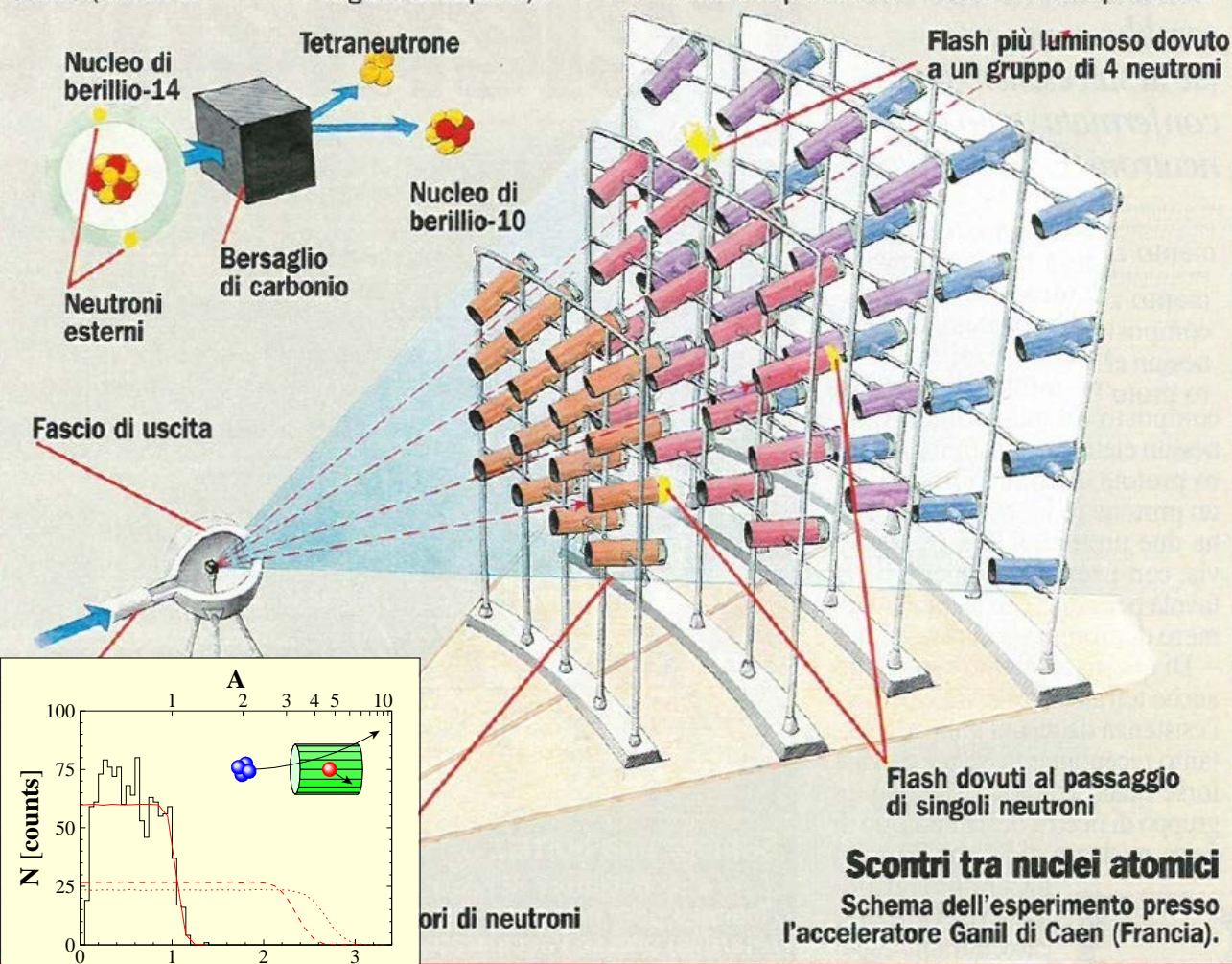

FMM, PRC 65 (2002) 044006

→ bound  ${}^4n$  : ✓

→  $E_R \lesssim 2 \text{ MeV}$  ? ✓

FMM, arXiv:nucl-ex/0504009

Focus magazine (2002)

► The DEMON campaigns :

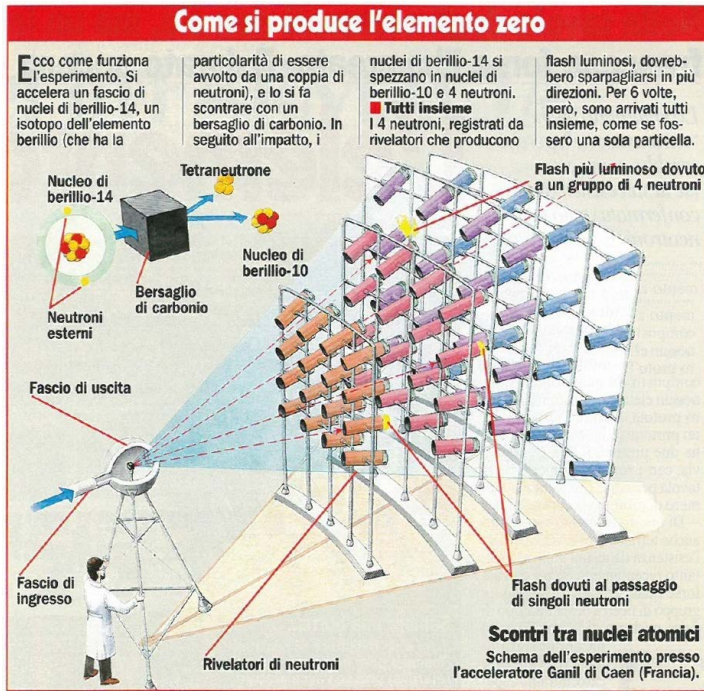

► MUST collaboration :

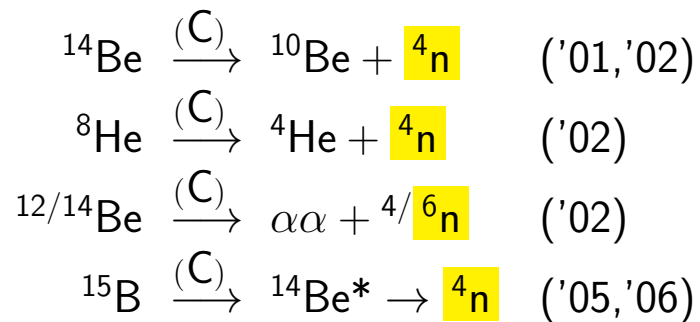
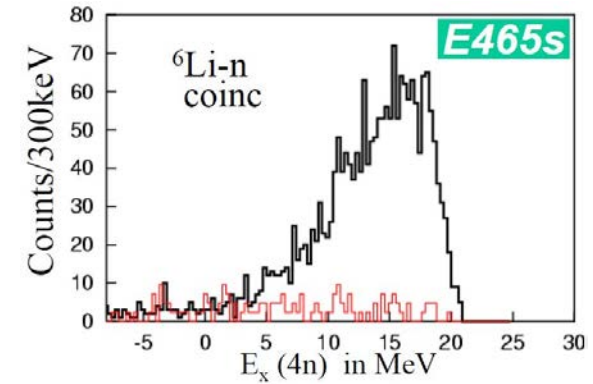

⇒ experimental program stopped ...

► The DEMON campaigns :

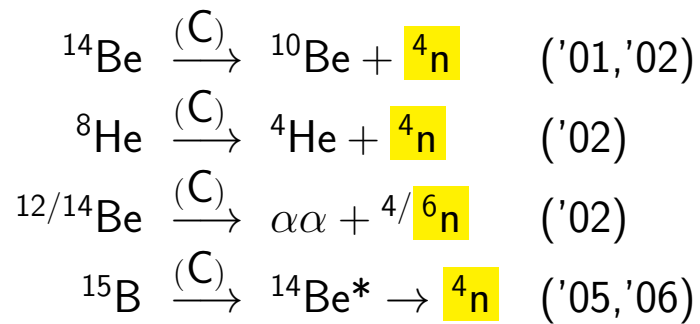
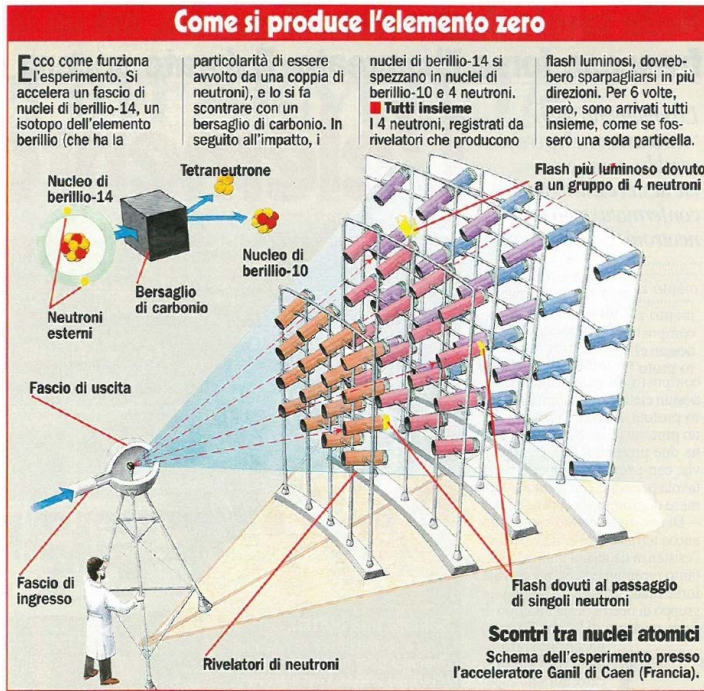

⇒ experimental program stopped ...

► MUST collaboration :

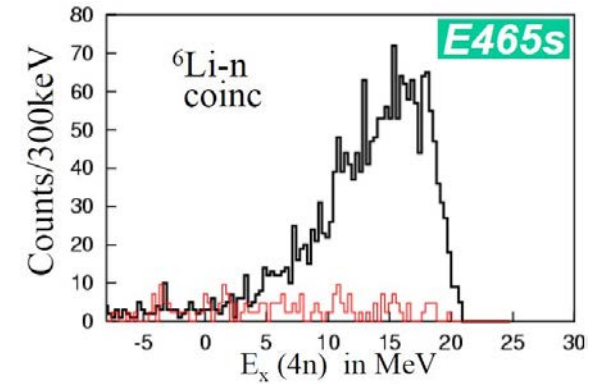
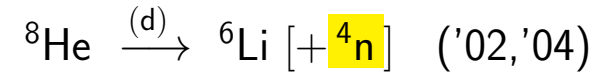

► Shimoura et al (SHARAQ) :

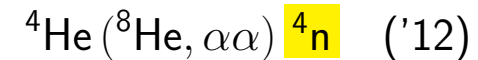
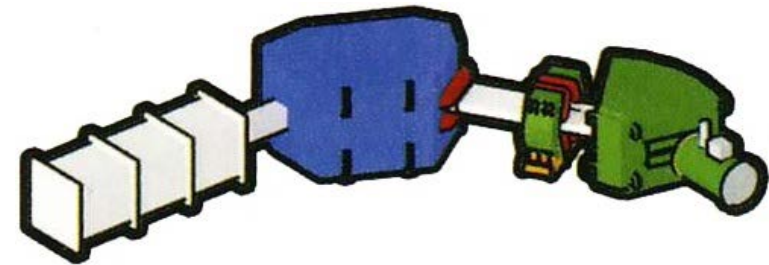

Kisamori, Shimoura, PRL 116 (2016) 052501

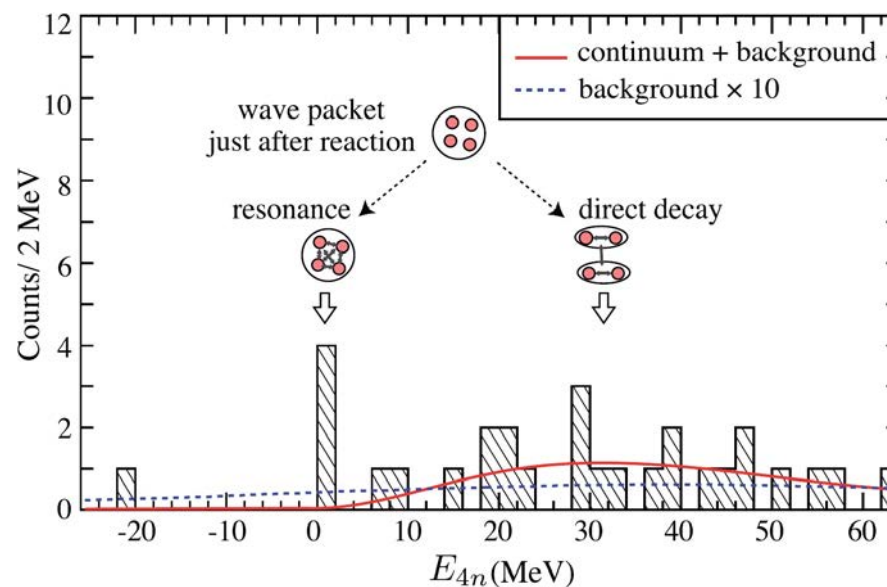
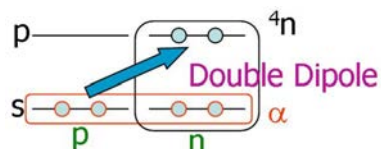
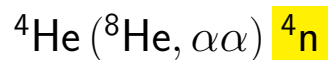
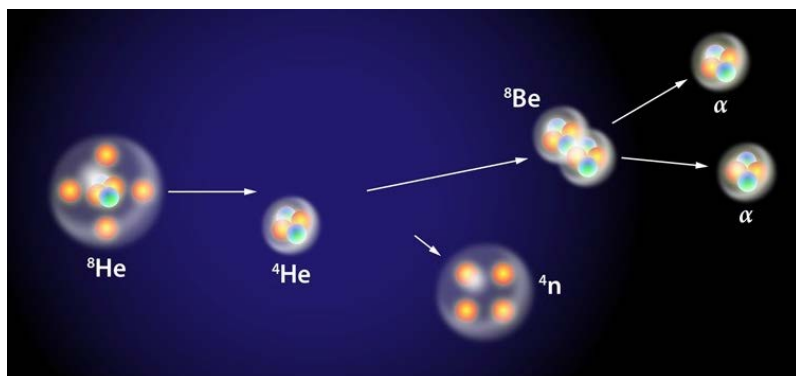

- only 1 event in unphysical region
- 4 events close to threshold !

$E(^4\text{n}) = 0.8 \pm 1.3 \text{ MeV}$

$\Gamma(^4\text{n}) < 2.6 \text{ MeV}$

$\sigma(^4\text{n}) \sim 4 \text{ nb}$

→ resonance ? ✓

→ bound  $^4\text{n}$  ? ✓

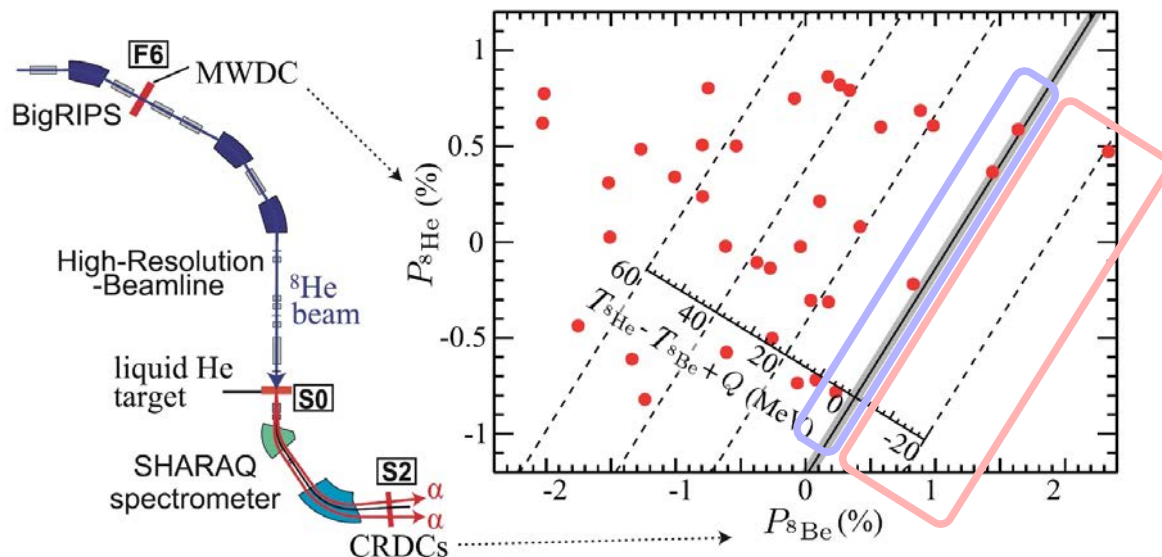

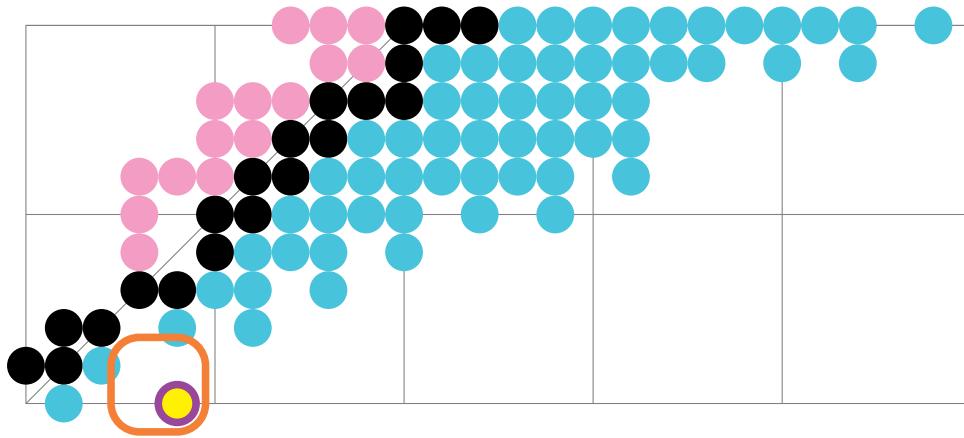

► H isotopes with  $4N$  or  $4n$  are unbound :

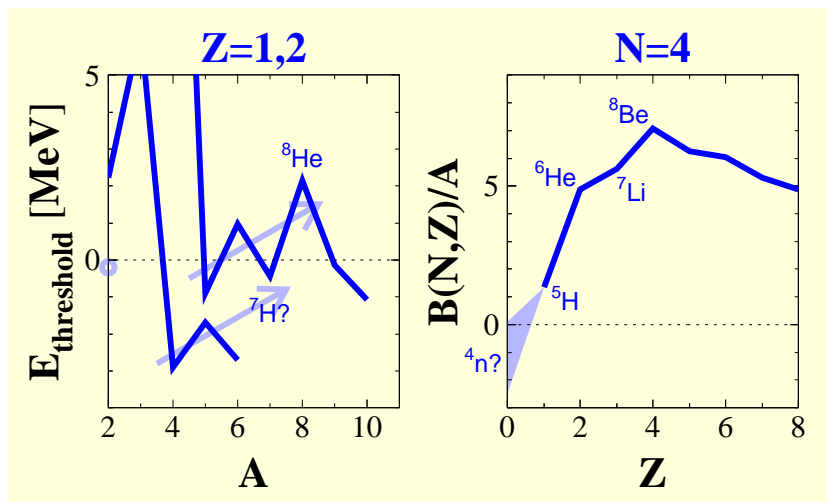

→ how could more n-rich systems be bound ?

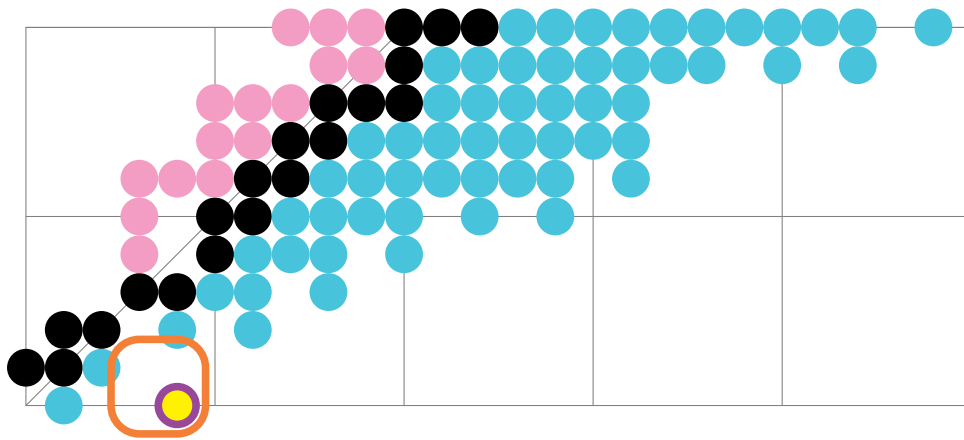

► In fact  ${}^4, {}^5\text{H}$  are 'bound' !

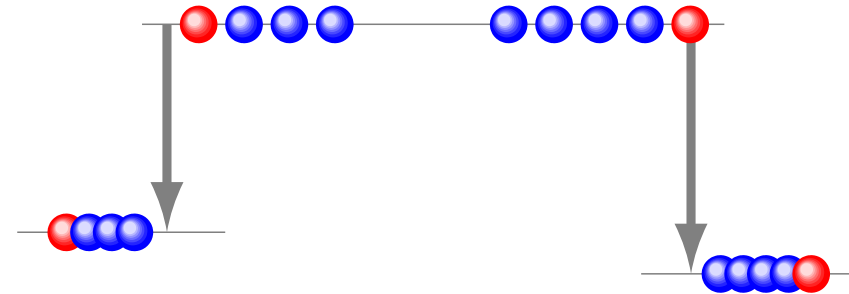

► H isotopes with  $4N$  or  $4n$  are unbound :

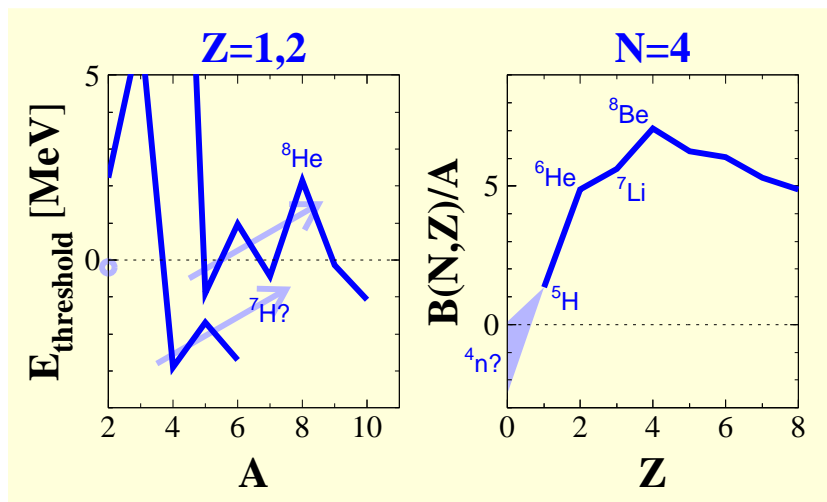

→ how could more n-rich systems be bound ?

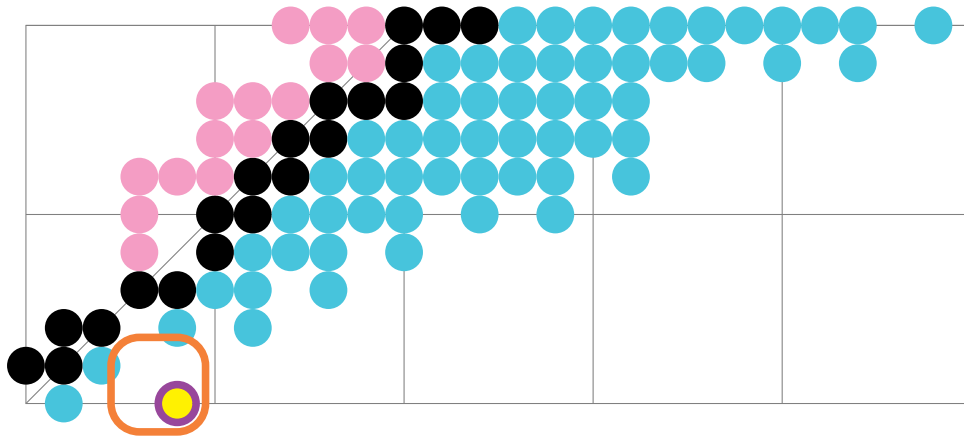

► In fact  ${}^4, {}^5\text{H}$  are 'bound' !

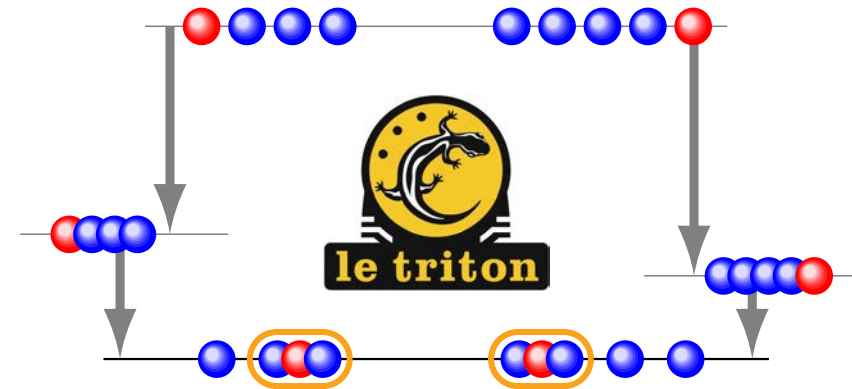

- only  $B({}^3\text{H})$  makes them unbound

► H isotopes with  $4N$  or  $4n$  are unbound :

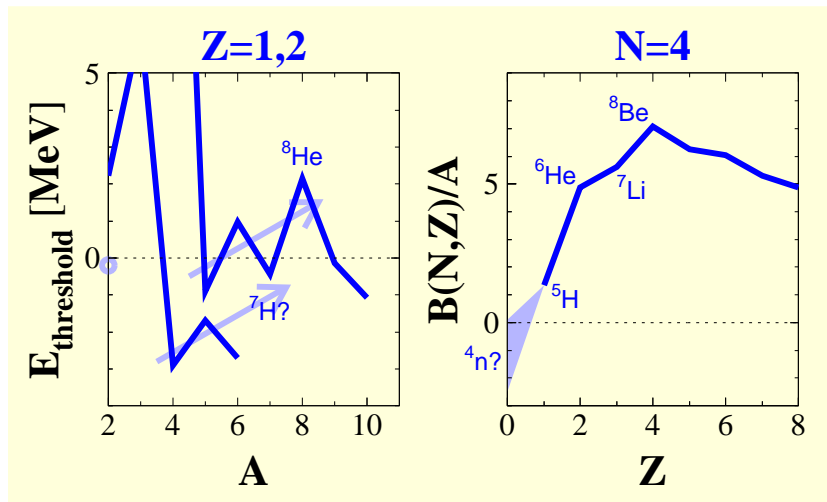

→ how could more n-rich systems be bound ?

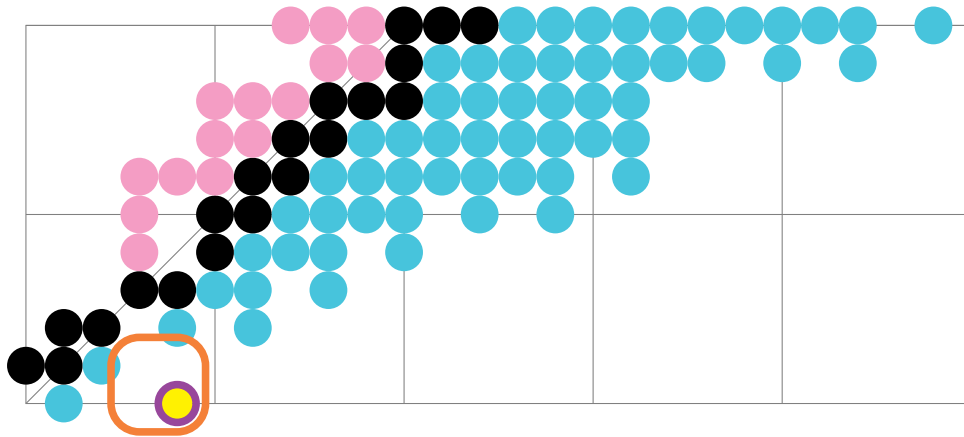

► H isotopes with  $4N$  or  $4n$  are unbound :

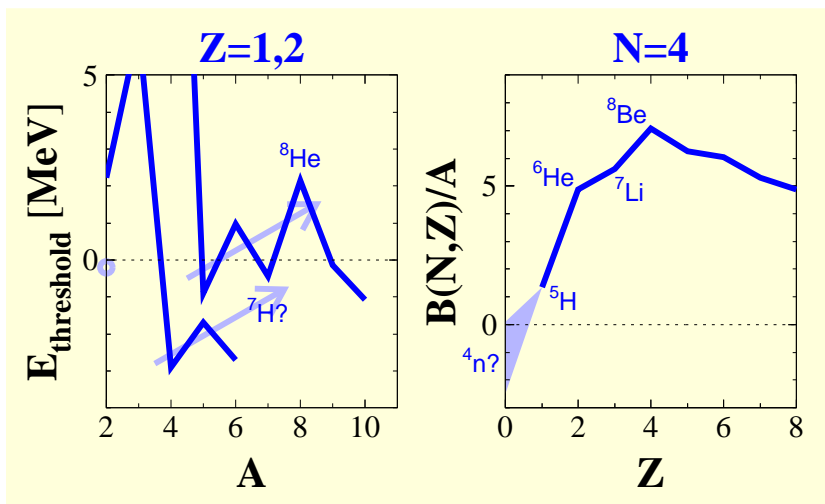

→ how could more n-rich systems be bound ?

► In fact  ${}^4, {}^5\text{H}$  are 'bound' !

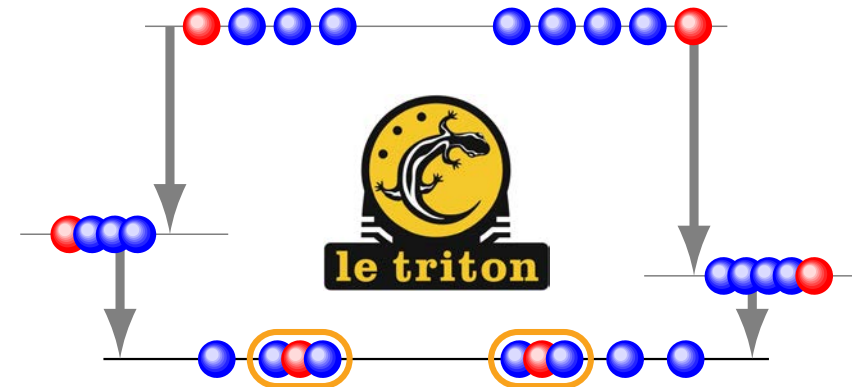

- only  $B({}^3\text{H})$  makes them unbound

► No 'triton' in  $4n$  system :

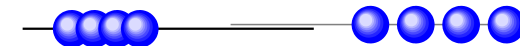

- **1 eV** binding would be enough !

- $B({}^4n) < \min\{S_{4n}\}$



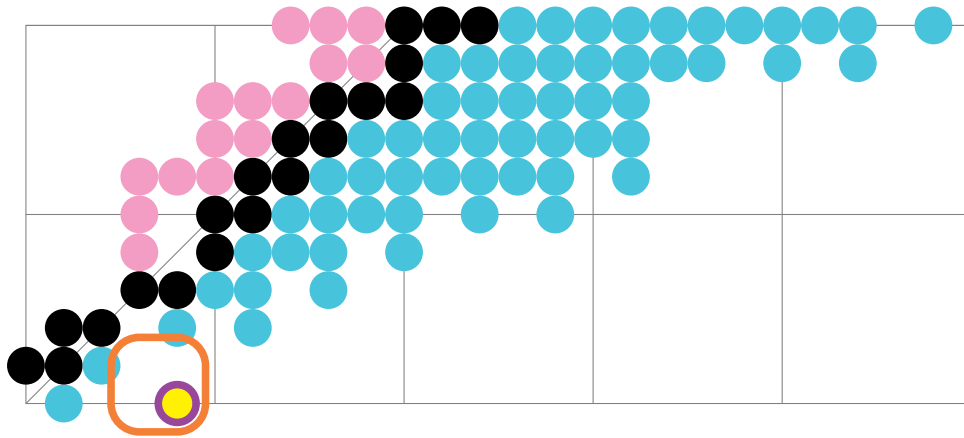

► H isotopes with  $4N$  or  $4n$  are unbound :

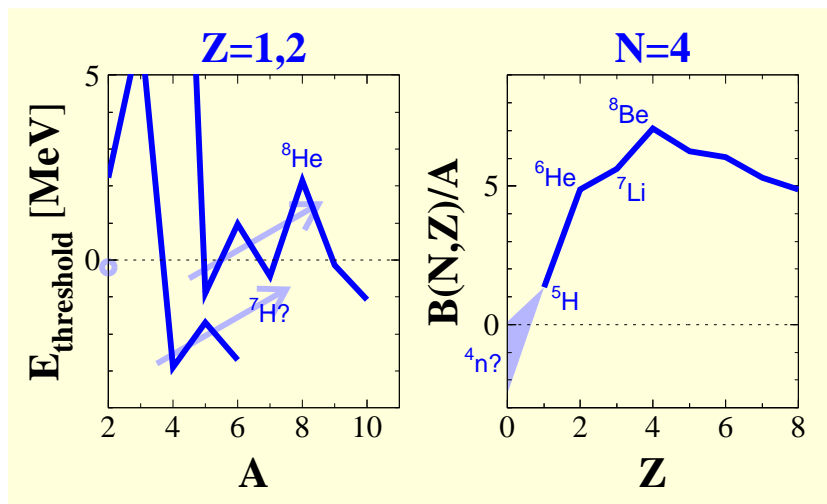

→ how could more n-rich systems be bound ?

► In fact  ${}^4, {}^5\text{H}$  are 'bound' !

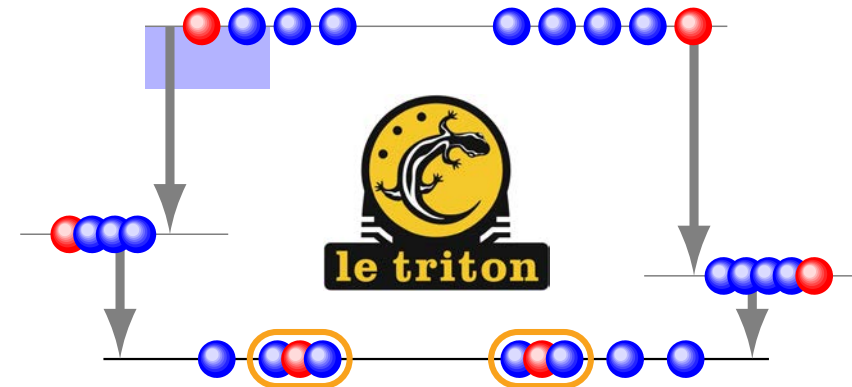

• only  $B({}^3\text{H})$  makes them unbound

► No 'triton' in  $4n$  system :



• 1 eV binding would be enough !

•  $B({}^4n) < \min\{S_{4n}\} \sim 1.5 \text{ MeV}$  ( ${}^{19}\text{B}$ )

→  ${}^4n$  would  $\beta$ -decay into  ${}^4\text{H}$

► **"ab initio"** = "*from first principles*"

- realistic interactions
- 'exact' calculations

$$H = \left\{ \sum_i^A T_i + \sum_{i<j}^A V_{ij} \right\} + \sum_{i<j<k}^A V_{ijk}$$

☞ Pieper, PRL 90 (2003) 252501

► **"ab initio"** = "from first principles"

- realistic interactions
- 'exact' calculations

$$H = \left\{ \sum_i^A T_i + \sum_{i<j}^A V_{ij} \right\} + \sum_{i<j<k}^A V_{ijk}$$

▣ Pieper, PRL 90 (2003) 252501

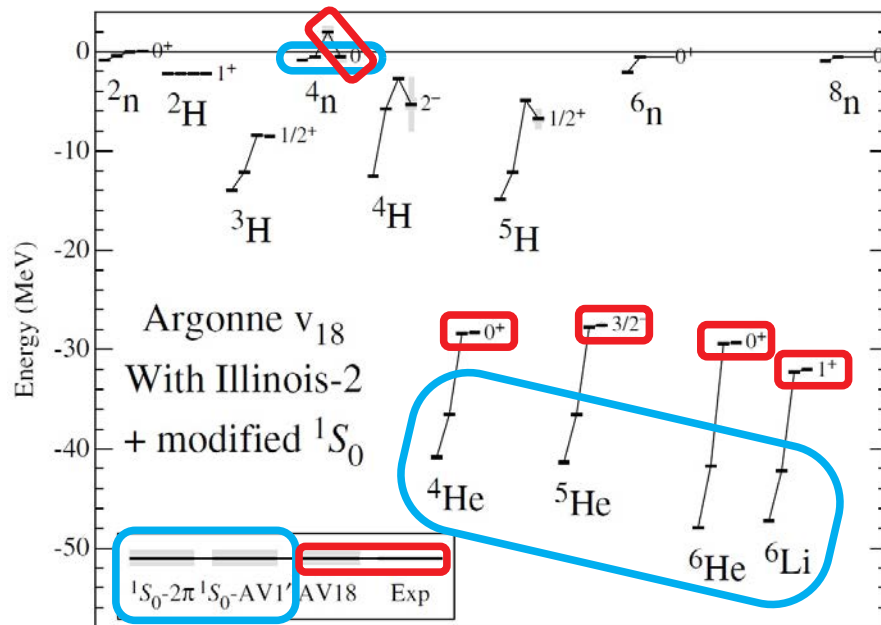

⇒ proof that  $^4n$  does not exist (?)

► **"ab initio"** = "from first principles"

- realistic interactions
- 'exact' calculations

$$H = \left\{ \sum_i^A T_i + \sum_{i<j}^A V_{ij} \right\} + \sum_{i<j<k}^A V_{ijk}$$

▣ Pieper, PRL 90 (2003) 252501

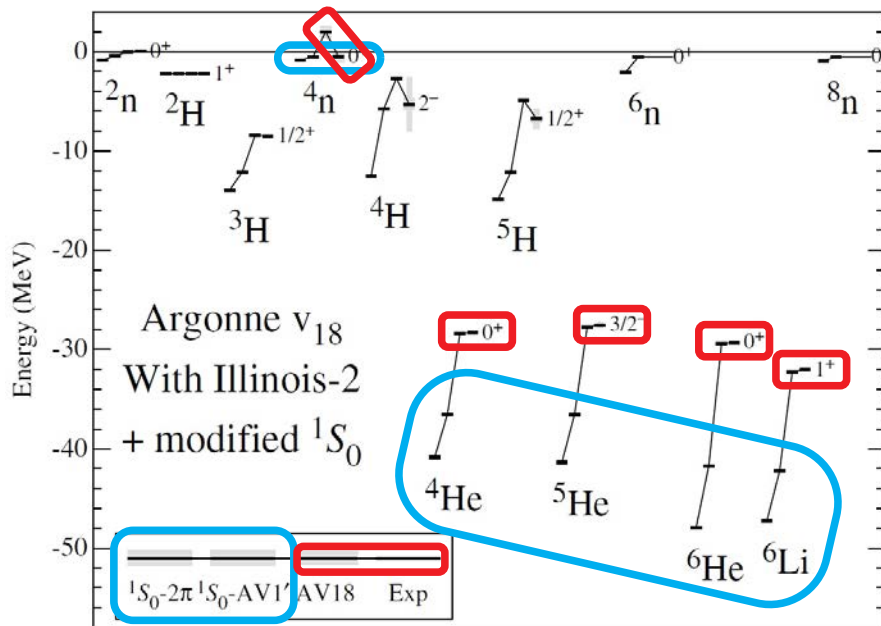

⇒ proof that  $^4n$  does not exist (?)

- $E(^4n) = -500$  keV : 'strongly' bound !
- $V_{ijk}$  not *ab initio* nor precise !
- exact to 1-2% ... of total E :  $\sim$  MeV !

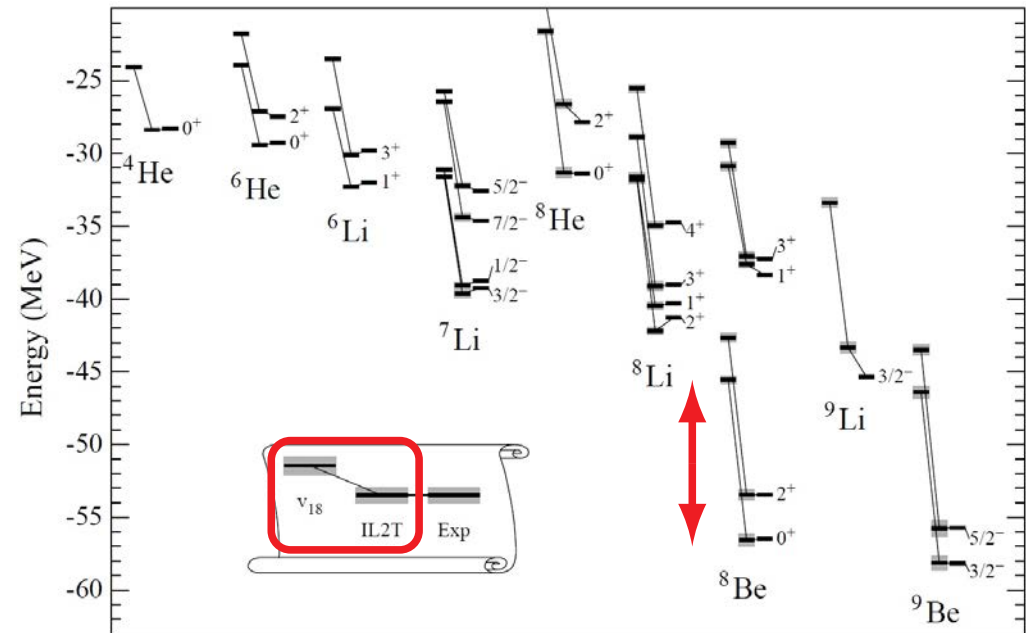

▶ **"ab initio"** = "from first principles"

- realistic interactions
- 'exact' calculations

$$H = \left\{ \sum_i^A T_i + \sum_{i<j}^A V_{ij} \right\} + \sum_{i<j<k}^A V_{ijk}$$

□ Pieper, PRL 90 (2003) 252501

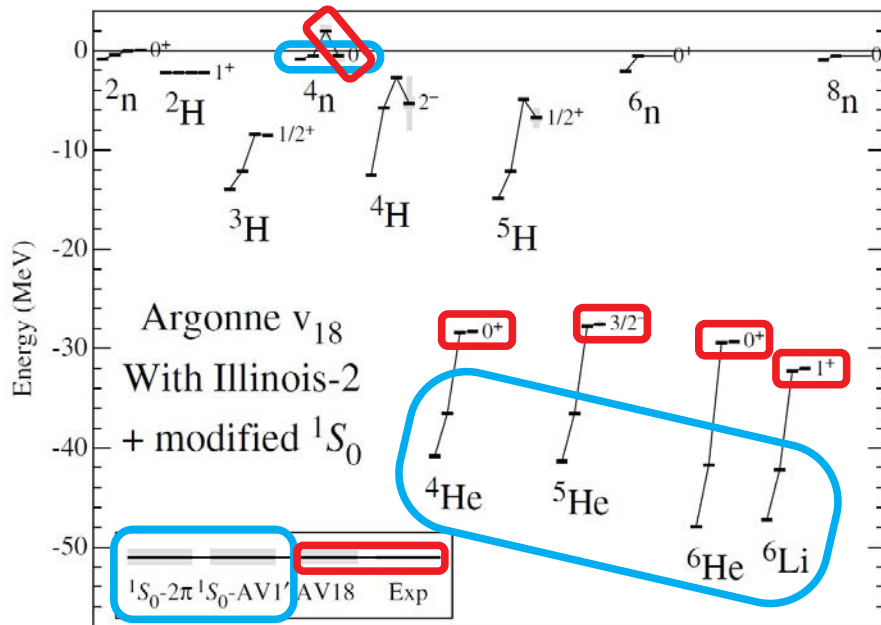

⇒ proof that  ${}^4\text{n}$  does not exist (?)

- $E({}^4\text{n}) = -500 \text{ keV}$  : 'strongly' bound !
- $V_{ijk}$  not *ab initio* nor precise !
- exact to 1-2% ... of total E :  $\sim \text{MeV}$  !

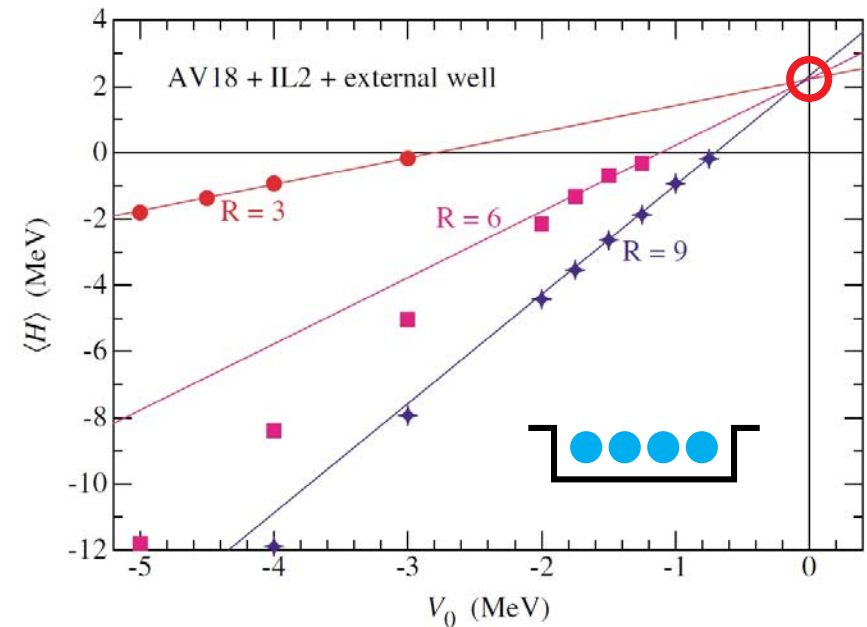

► **"ab initio"** = "from first principles"

- realistic interactions
- 'exact' calculations

$$H = \left\{ \sum_i^A T_i + \sum_{i<j}^A V_{ij} \right\} + \sum_{i<j<k}^A V_{ijk}$$

▣ Pieper, PRL 90 (2003) 252501

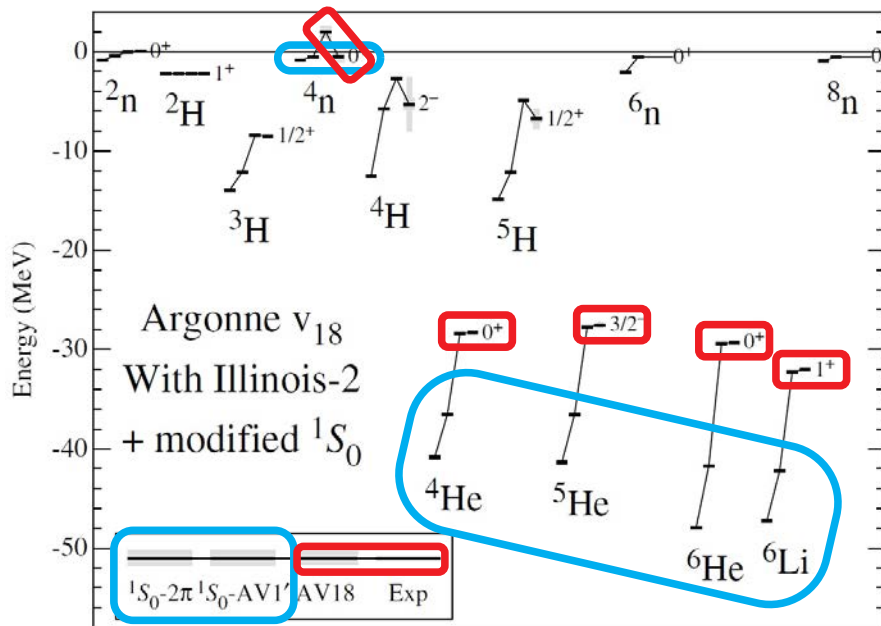

⇒ proof that  ${}^4\text{n}$  does not exist (?)

- $E({}^4\text{n}) = -500 \text{ keV}$  : 'strongly' bound !
- $V_{ijk}$  not *ab initio* nor precise !
- exact to 1-2% ... of total E :  $\sim \text{MeV}$  !

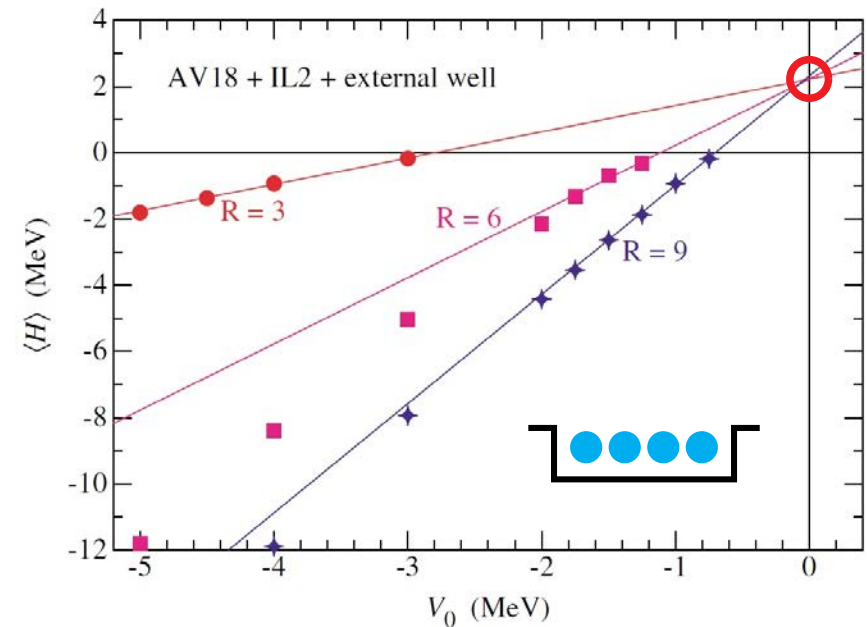

▣ Lazauskas, PRC 71 (2005) 044004

▣ Lazauskas, PRC 72 (2005) 034003

▣ Hiyama, PRC 93 (2016) 044004

▣ Shirokov, PRL 117 (2016) 182502

▣ Gandolfi, PRL 118 (2017) 232501

▣ Fosse, PRL 119 (2017) 032501

→ bound  ${}^4\text{n}$  : ✗  
→ resonance ? (✓)

## ① The $A_n$ context :

- XX century :  $\sigma(A_n)$  & backgrounds ...
- XXI century : first signals !
  - GANIL : theory & experiments
  - RIKEN : more candidate events
- experimental constraints
- theoretical 'proofs' ?

## ② The RIKEN campaign :

- SHARAQ 2.0 :  ${}^4\text{He}({}^8\text{He}, \alpha\alpha){}^4\text{n}$
- NEBULA+NeuLAND & MINOS :
  - ${}^8\text{He}(p, p\alpha){}^4\text{n}$  : 4n without FSI
  - ${}^8\text{He}(p, 2p)\{{}^3\text{H}+{}^4\text{n}\}$  : any  $(E, \Gamma)_R$

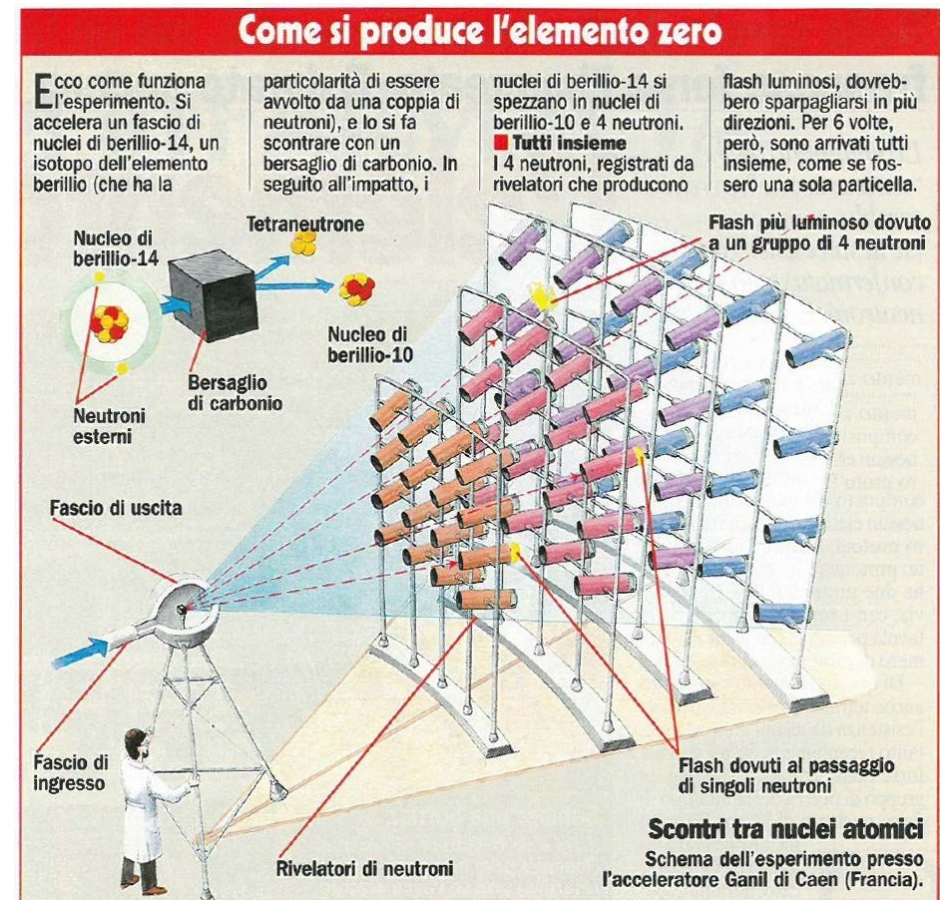

- ▶ Three experiments : same beam ( ${}^8\text{He}$ ) & energy (150–200 MeV/N) ?

reaction	initial state	final state	$\sigma$	results
${}^4\text{He} ({}^8\text{He}, \alpha\alpha) {}^4\text{n}$ <small>Shimoura, NP1512-SHARAQ10</small>			nb	$N_{\text{evt}} \sim 10\text{ s}$ ${}^4\text{n} : E, \Gamma$
${}^8\text{He} (p, p\alpha) {}^4\text{n}$ <small>Paschalis, NP1406-SAMURAI19</small>			$\mu\text{b}$	$N_{\text{evt}} \sim 1000\text{ s}$ ${}^4\text{n} : E, \Gamma$
${}^8\text{He} (p, 2p) \{ {}^3\text{H} + {}^4\text{n} \}$ <small>FMM/Yang, NP1512-SAMURAI34</small>			mb	$N_{\text{evt}} \sim 10,000\text{ s}$ ${}^4\text{n} \& {}^7\text{H} : E, \Gamma, \Omega$





- ▶ Three experiments : same beam ( $^8\text{He}$ ) & energy (150–200 MeV/N) ?

reaction	initial state	final state	$\sigma$	results
$^4\text{He} (^8\text{He}, \alpha\alpha) ^4\text{n}$ <small>Shimoura, NP1512-SHARAQ10</small>			nb	$N_{\text{evt}} \sim 10\text{ s}$ $^4\text{n} : E, \Gamma$
$^8\text{He} (p, p\alpha) ^4\text{n}$ <small>Paschalis, NP1406-SAMURAI19</small>			$\mu\text{b}$	$N_{\text{evt}} \sim 1000\text{ s}$ $^4\text{n} : E, \Gamma$
$^8\text{He} (p, 2p) \{^3\text{H} + ^4\text{n}\}$ <small>FMM/Yang, NP1512-SAMURAI34</small>			mb	$N_{\text{evt}} \sim 10,000\text{ s}$ $^4\text{n} \& ^7\text{H} : E, \Gamma, \Omega$

- ('16) SHARAQ 2.0 : {DAQ, tracking, calib.}  $\Rightarrow$  stat. & res.  $\times 5$
  - ('17) QFS (p,p $\alpha$ ) :  $\theta_{\text{cm}} \lesssim 180^\circ \Rightarrow 4\text{n}$  without FSI
  - ('17) 4n decay of  $^7\text{H} \Rightarrow$  high stat. & res. for any  $^7\text{H}$  and  $^4\text{n}$  state
- }  $\Rightarrow$  definitive answer !

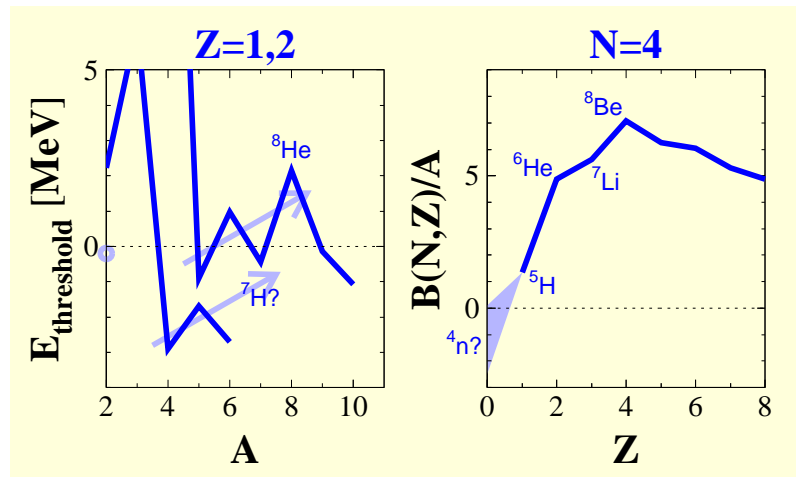
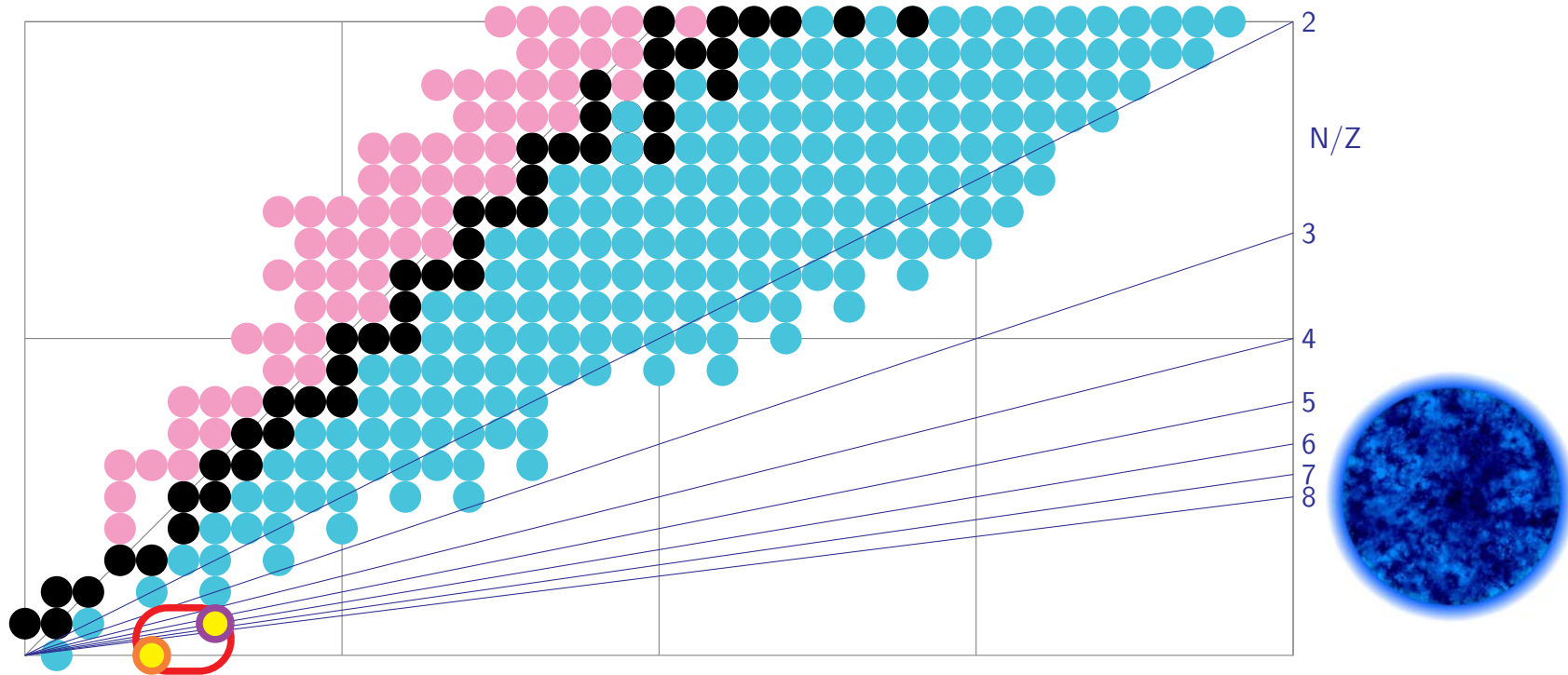

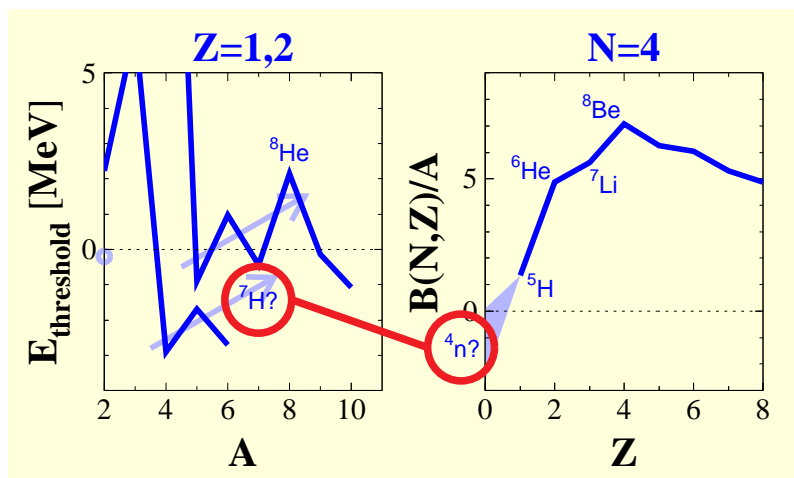
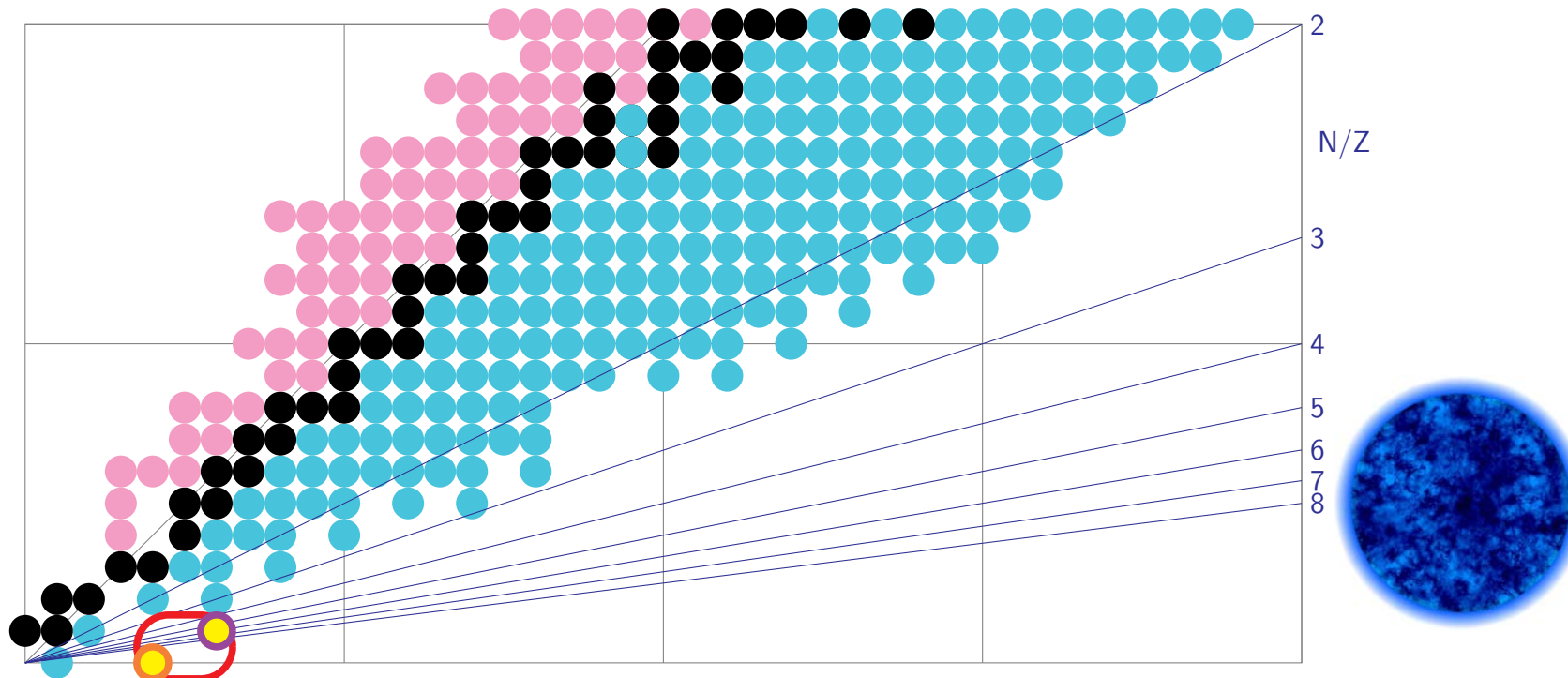

► Ambiguous and contradictory signals :

- low statistics & resolutions
- backgrounds (targets, binary channels)
- missing mass : no neutron detection

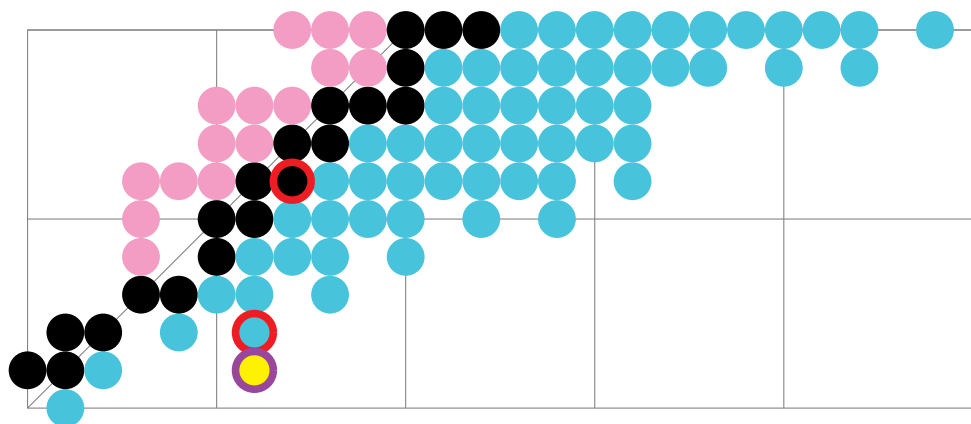

▶  ${}^8\text{He}(p,2p){}^7\text{H}$  @ 190 MeV/N :

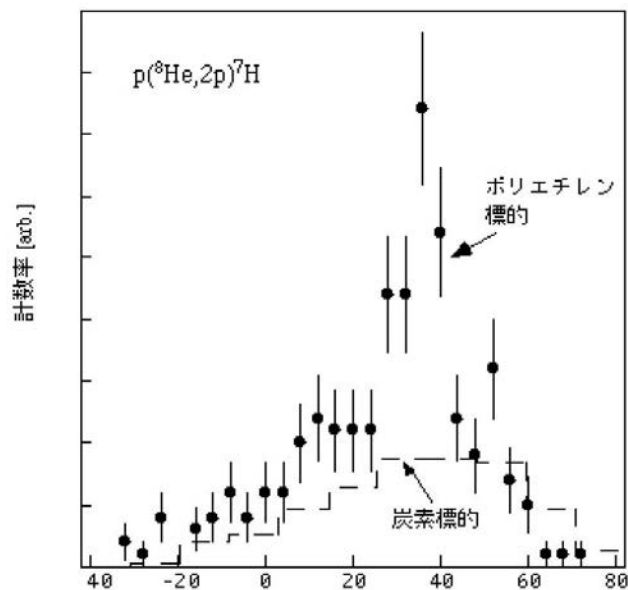

$p({}^8\text{He},2p){}^7\text{H}$ 反応の陽子分離エネルギー分布

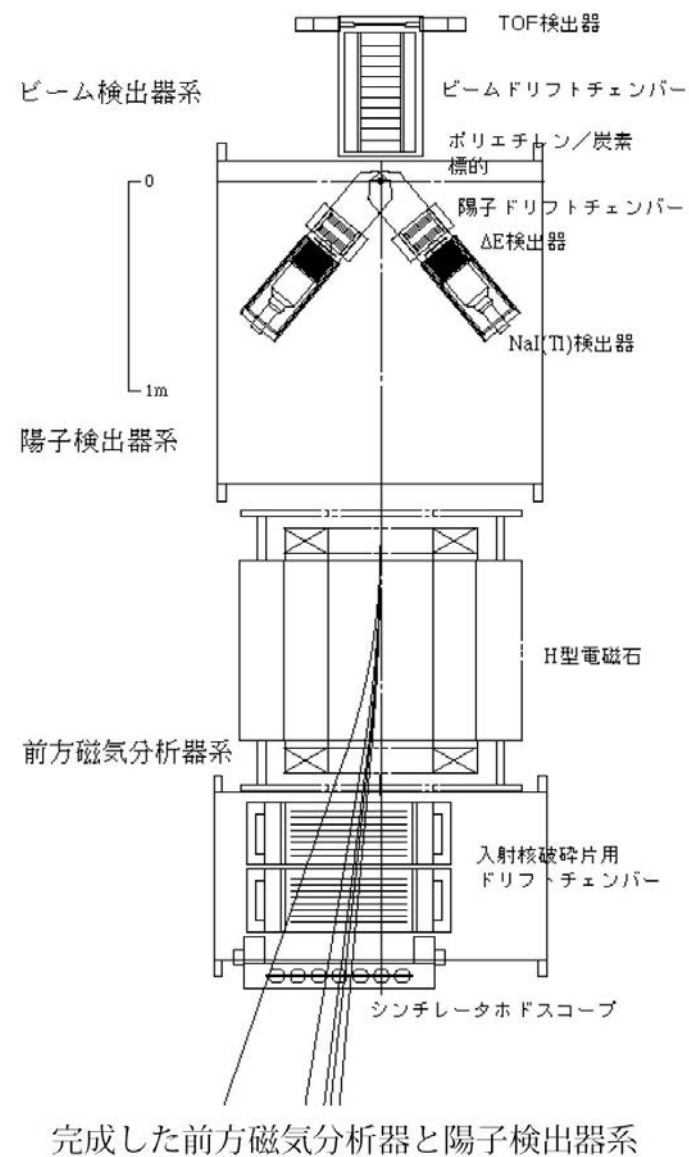

完成した前方磁気分析器と陽子検出器系

☐ Kobayashi, HIMAC Report H12 (2000)

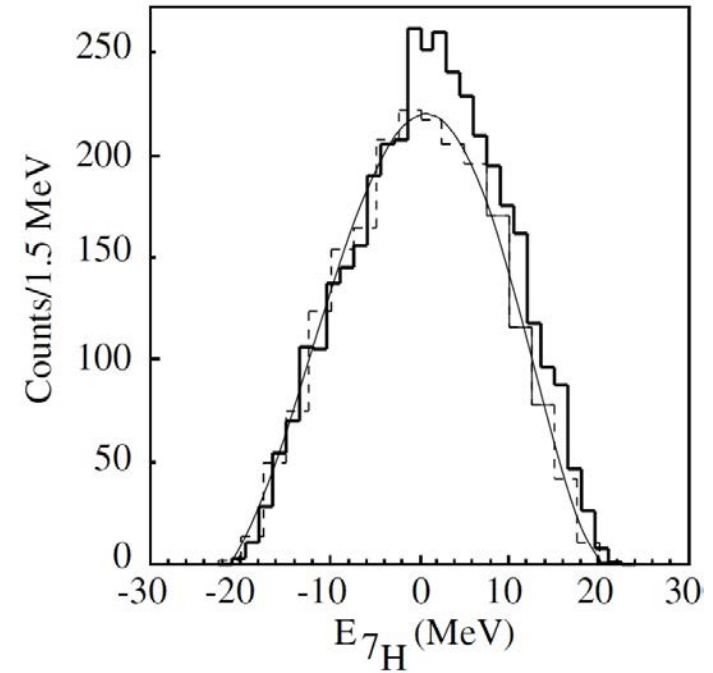
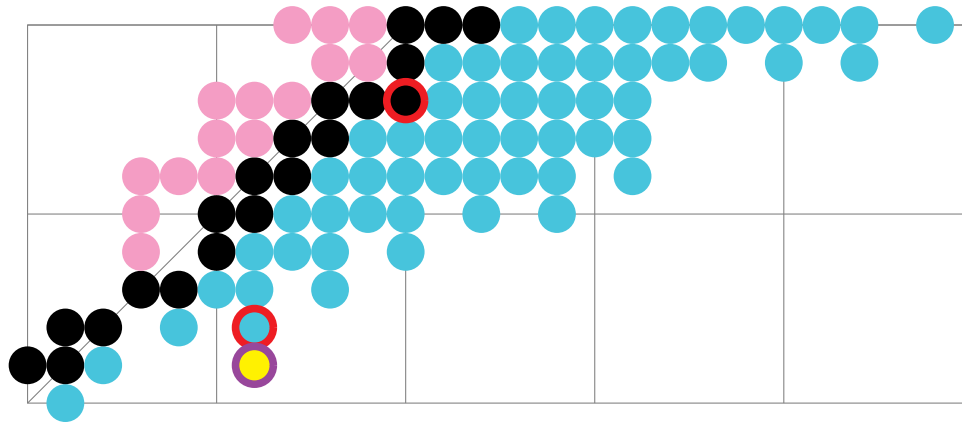

►  $^8\text{He} (p, 2p) ^7\text{H}$  @ 61 MeV/N :

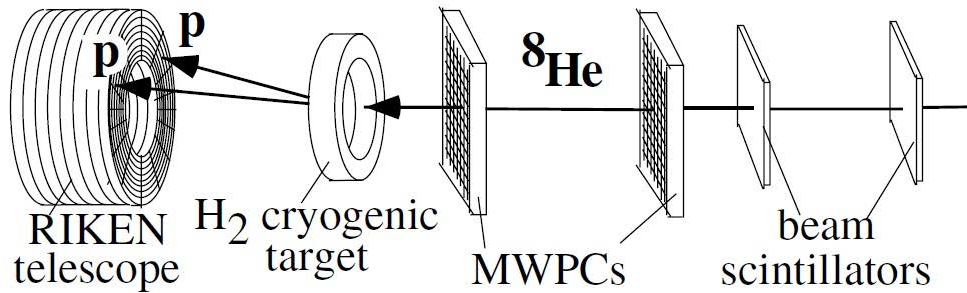

📄 Korsheninnikov, PRL 90 (2003) 082501

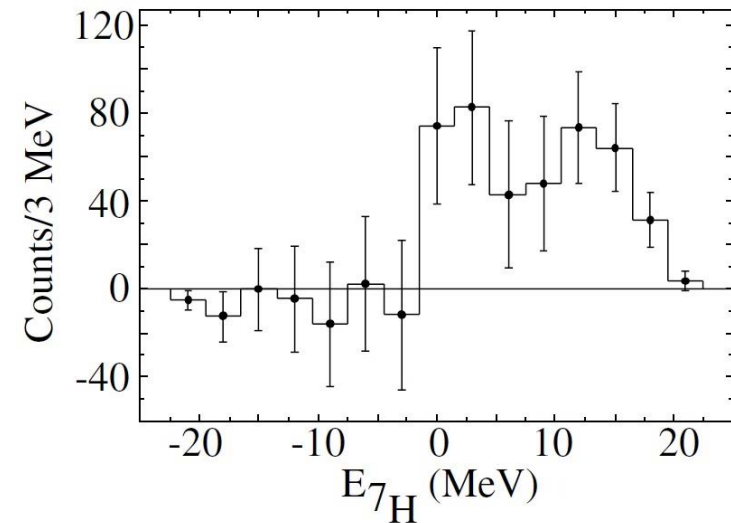

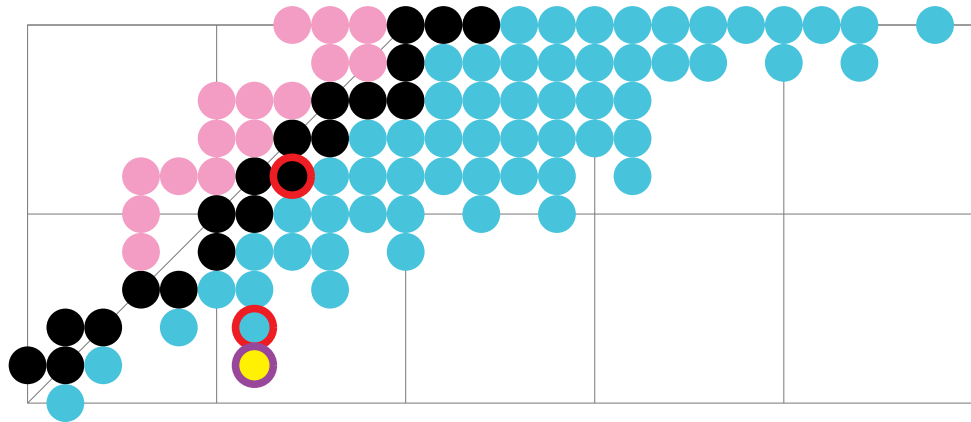

►  ${}^8\text{He}({}^{12}\text{C}, {}^{13}\text{N}) {}^7\text{H}$  @ 15 MeV/N :

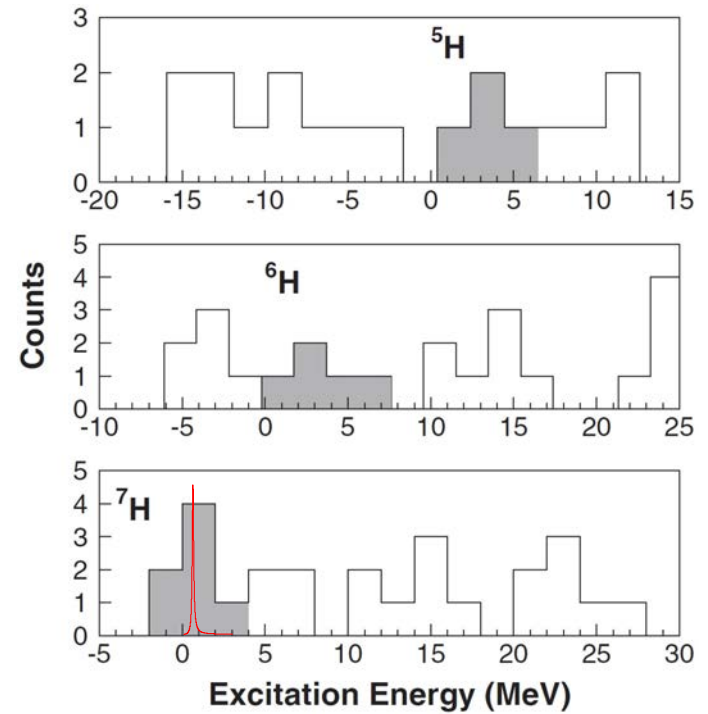

“represents an **unambiguous** proof”

•  $E_{\text{gs}}({}^7\text{H}) = 0.6 \pm 0.3 \text{ MeV}$  ( $\Gamma \sim 0.1$ )

⇒ { low resolution & statistics  
no mass identification for  ${}^A\text{N}$   
only part of triton branch ...

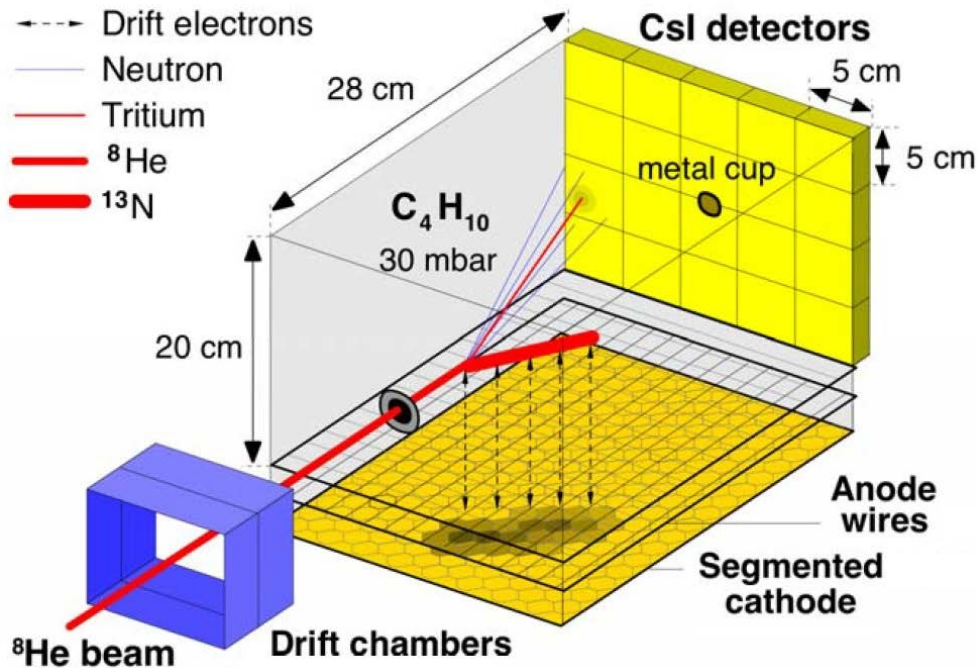

Caamaño, PRL 99 (2007) 062502

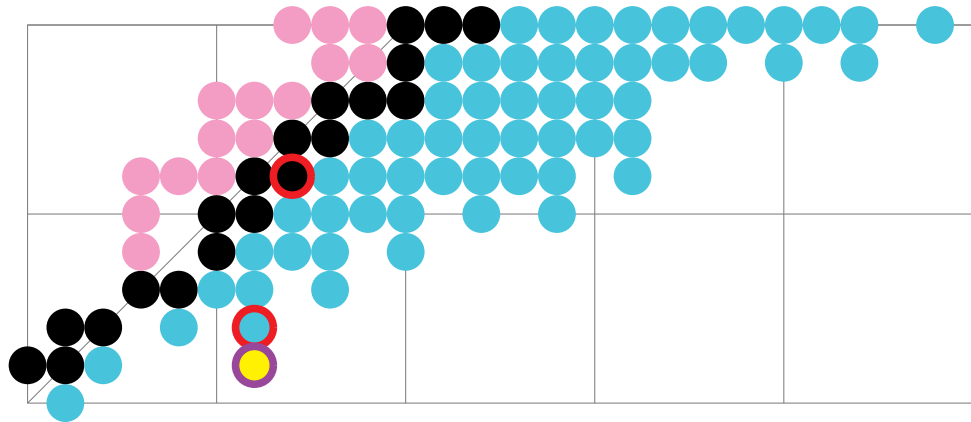

►  $^8\text{He}(d, ^3\text{He}) ^7\text{H}$  @ 15 MeV/N :

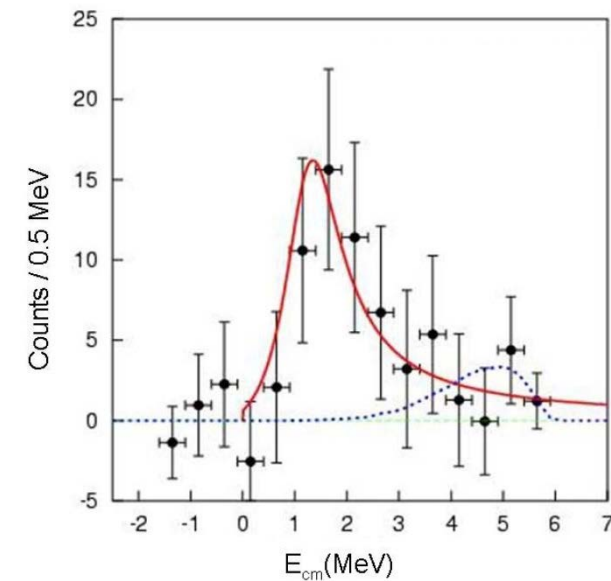
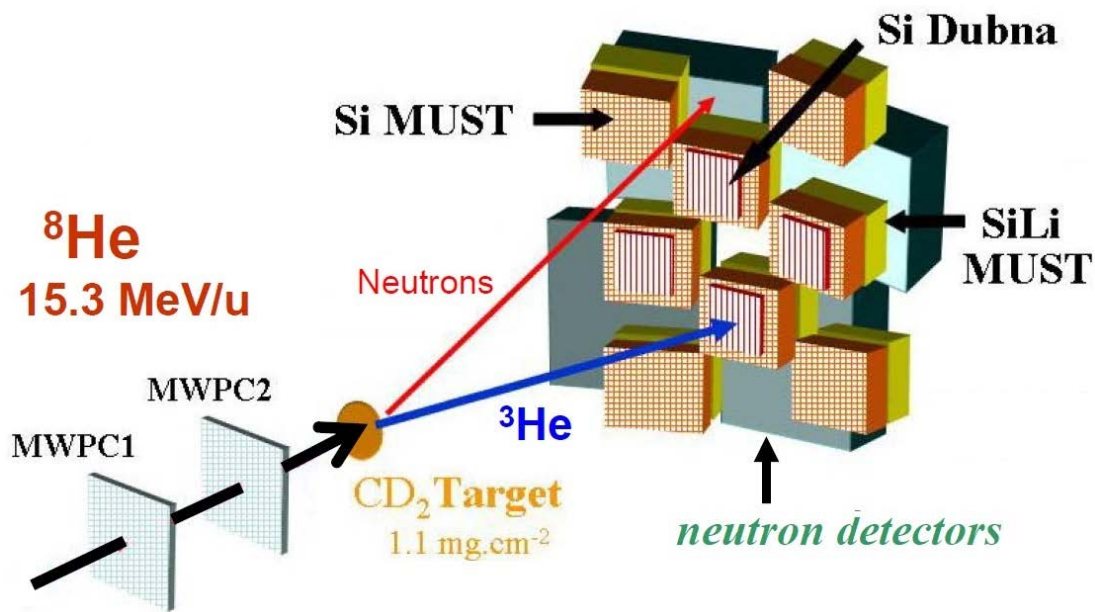
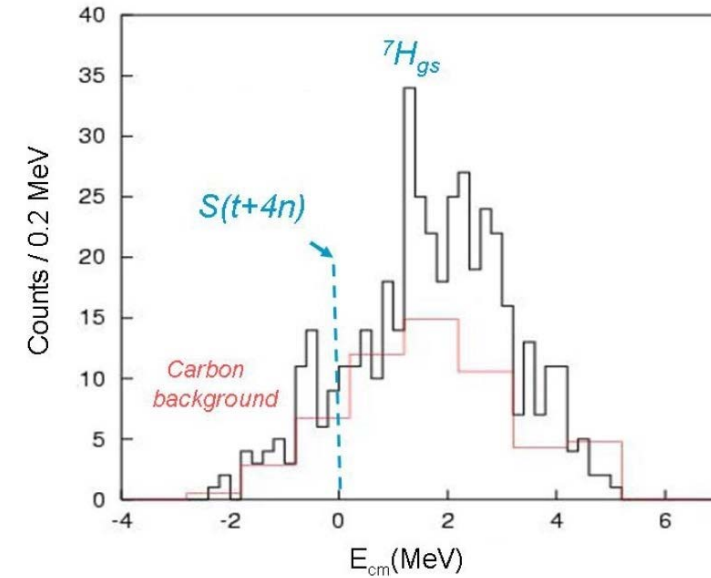

Beaume, PISA Workshop (2008)

Fortier, EXON Symposium (2006)



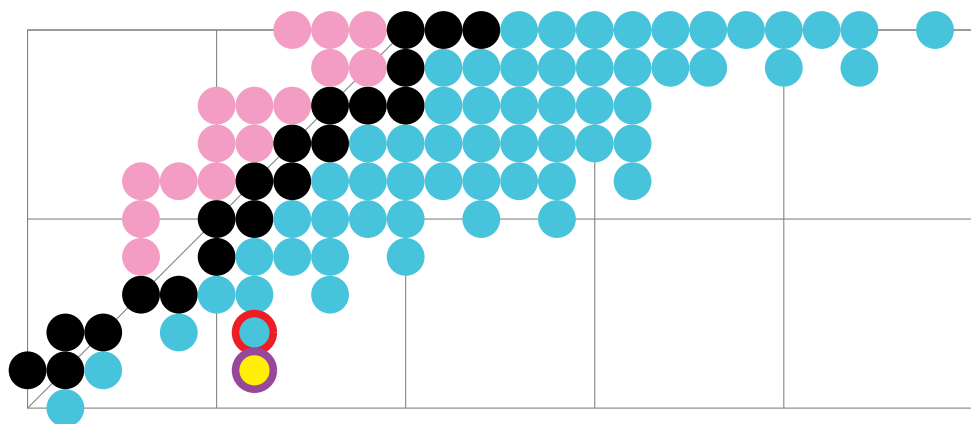

►  ${}^8\text{He}(d, {}^3\text{He}) {}^7\text{H}$  @ 42 MeV/N :

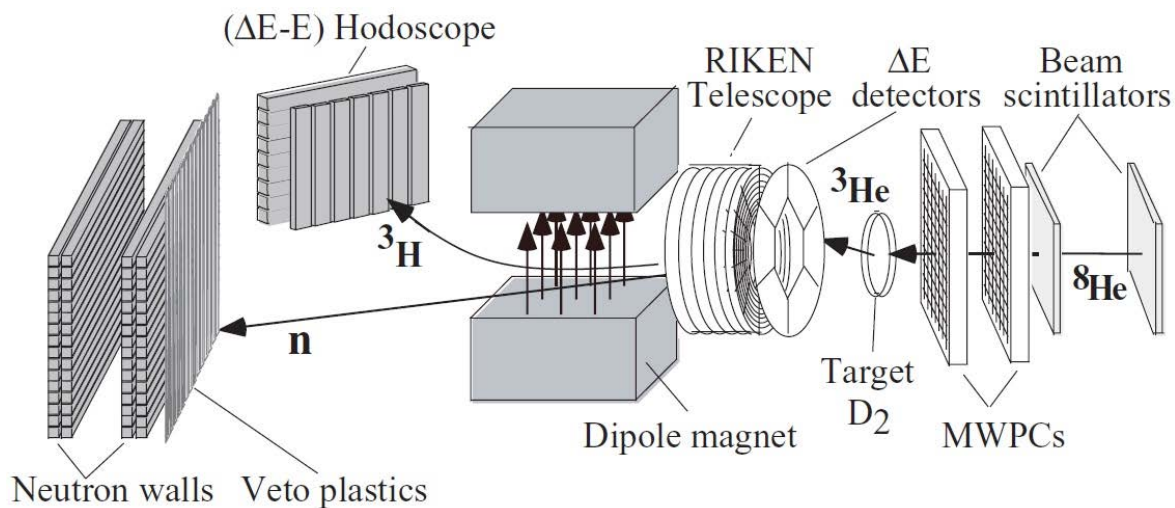
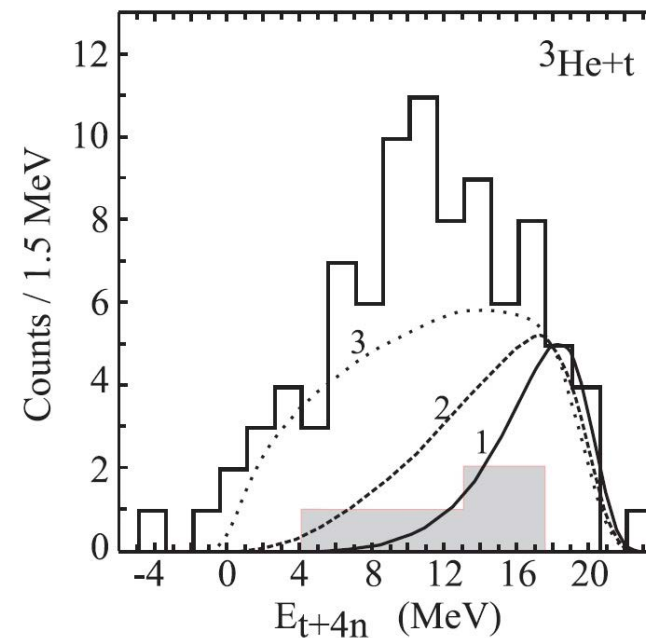

“a peculiarity at  $\sim 2$  MeV” ?

- 1) 5-body (t+n+n+n+n) PS
- 2) 3-body (t+2n+2n) PS

📄 Nikolskii, PRC 81 (2010) 064606

# Another 'Russian' Hydrogen 7 (and a 4n) ?

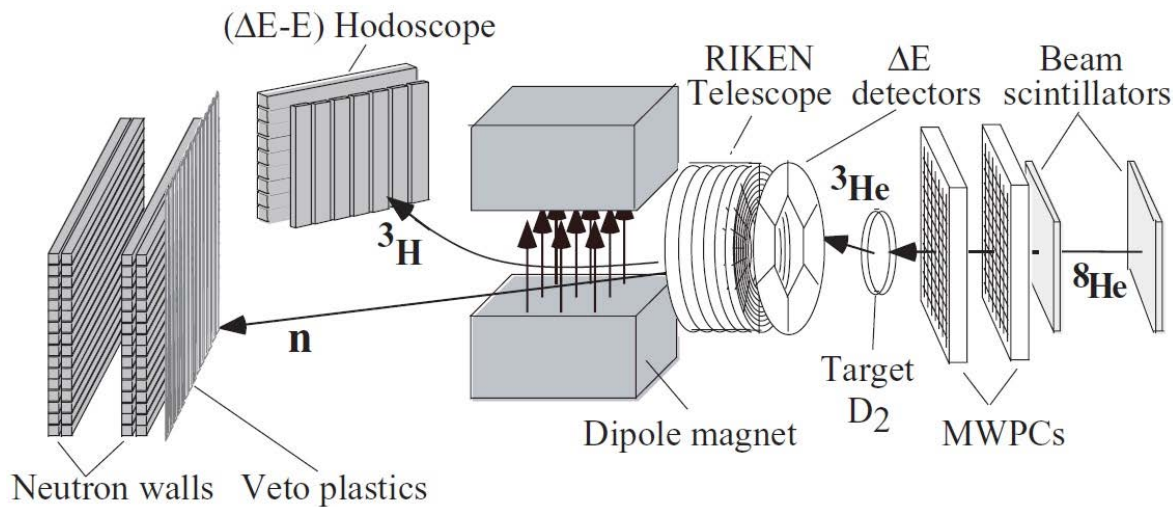
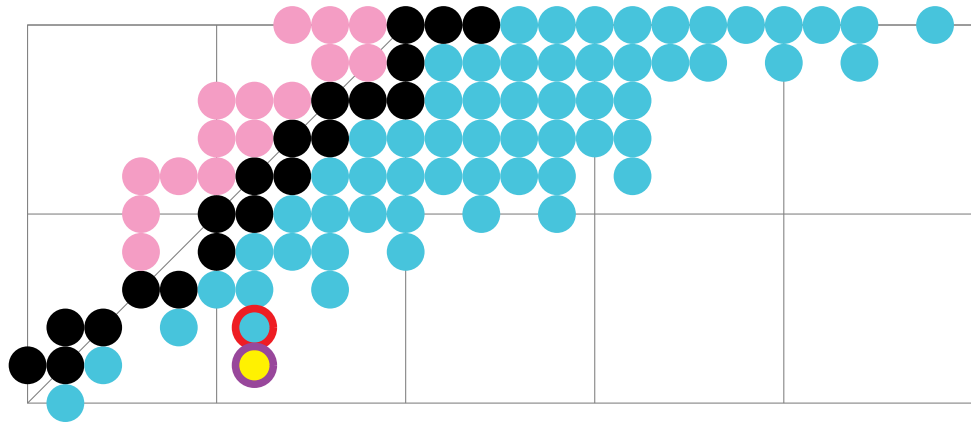

Nikolskii, PRC 81 (2010) 064606

►  ${}^8\text{He}(d, {}^3\text{He}) {}^7\text{H}$  @ 42 MeV/N :

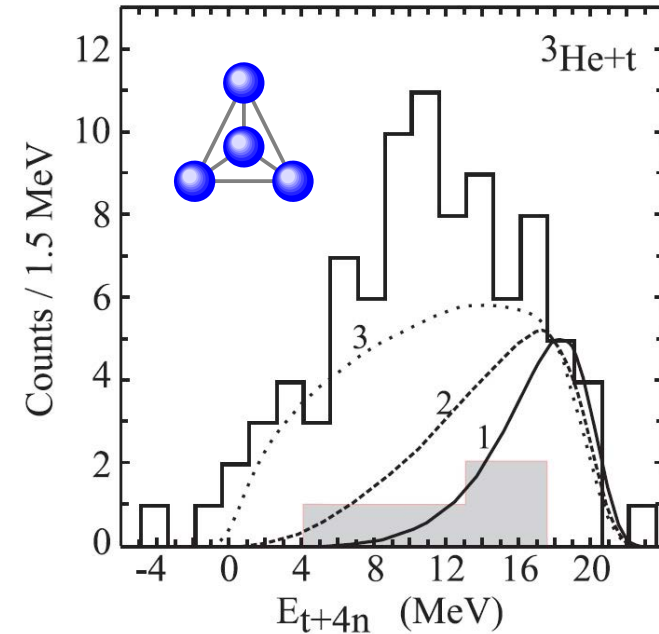

“a peculiarity at  $\sim 2$  MeV” ?

- 1) 5-body (t+n+n+n+n) PS
- 2) 3-body (t+2n+2n) PS
- 3) 2-body (t+4n) PS !

⇒ “extreme, unrealistic case” !!!

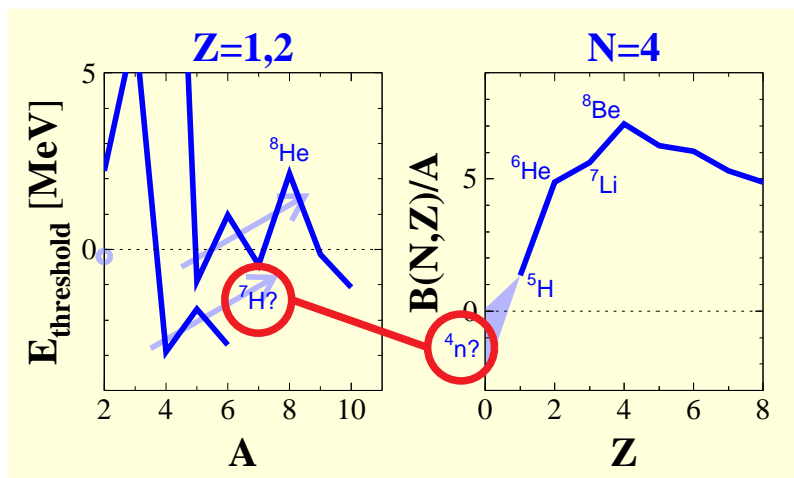
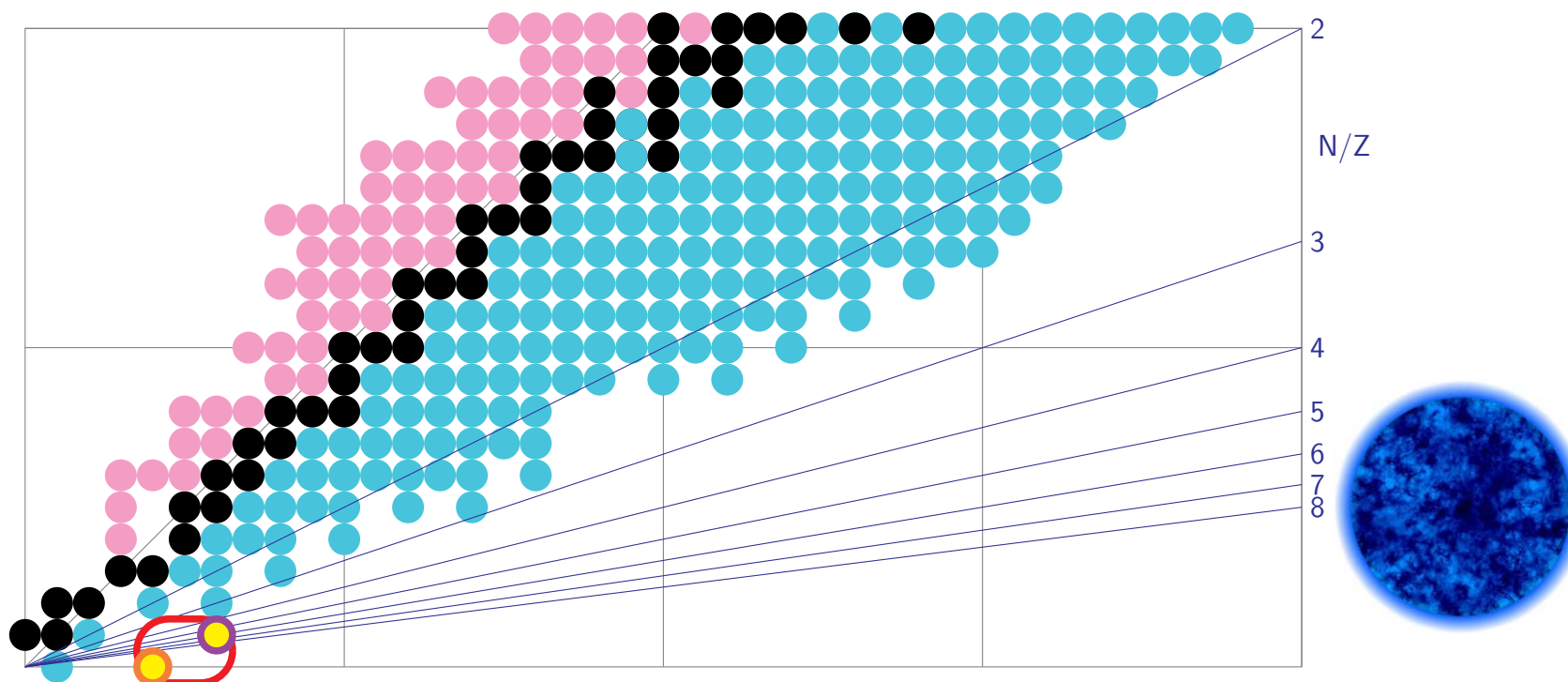

► Ambiguous and contradictory signals :

- low statistics & resolutions
- backgrounds (targets, binary channels)
- missing mass : no neutron detection

⇒  ${}^7\text{H}$  &  ${}^4\text{n}$  proposal with  $\varepsilon(4\text{n}) \gg 0$  !

► Expand NEBULA **multi-n** capabilities :

- France : LPC, IRFU, IPNO
- Japan : TITech, RIKEN

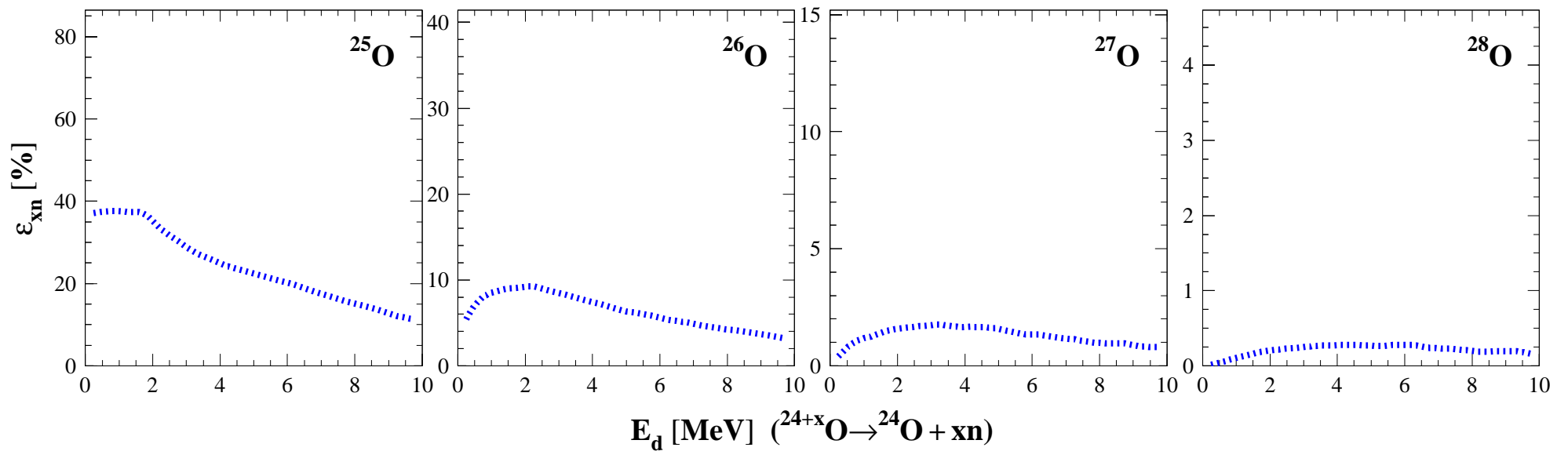
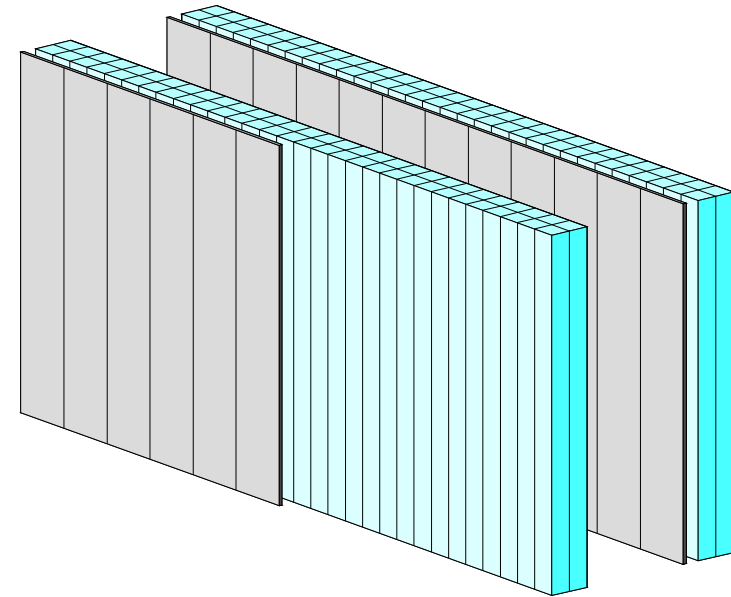

(  $\varepsilon_{xn} < \varepsilon_n^x$  due to neutron cross-talk) FMM, NIM A 450 (2000) 109

► Expand NEBULA **multi-n** capabilities :

- France : LPC, IRFU, IPNO
- Japan : TITech, RIKEN
- +90 bars : Comm. & Day-1 in 2019
- suggested configuration :

⇒  $\varepsilon(4n)$  enhanced  $\sim \times 16$  !

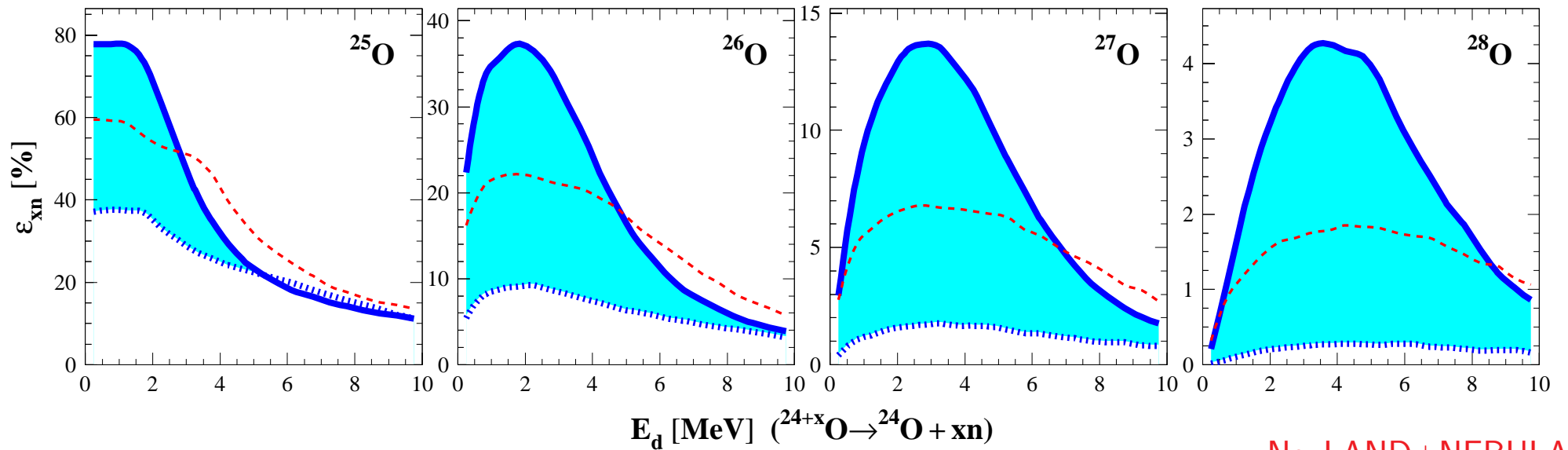
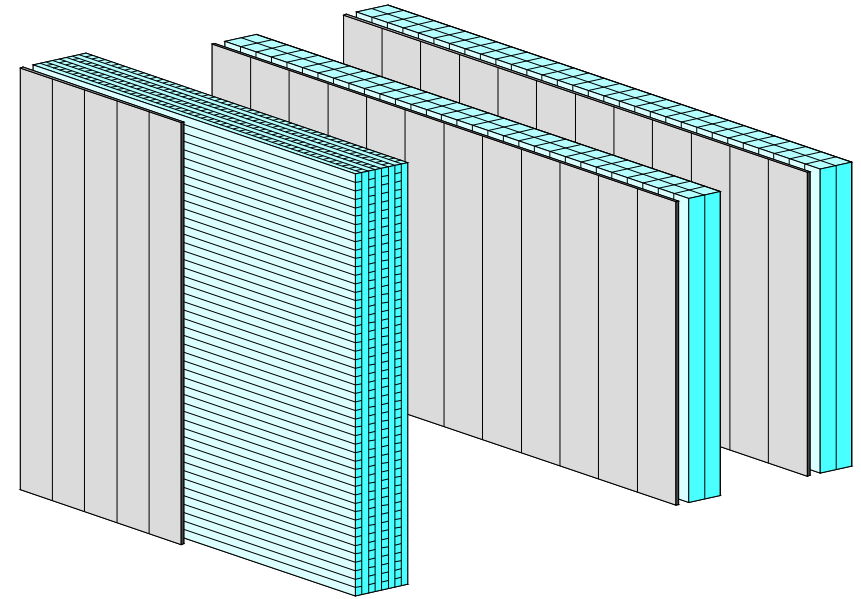

(  $\varepsilon_{xn} < \varepsilon_n^x$  due to neutron cross-talk ) FMM, NIM A 450 (2000) 109

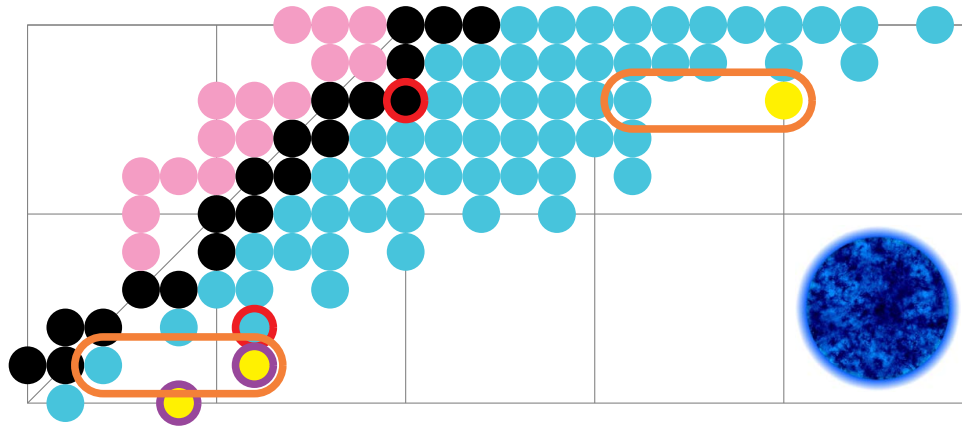

►  ${}^8\text{He}(p,2p){}^7\text{H}$  @ 150 MeV/N :

*“Many-neutron systems:  
search for superheavy Hydrogen 7  
and its Tetraneutron decay”*

☞ Yang & FMM, RIBF NP1512-SAMURAI34

● follow up of ☞ Orr, RIBF NP1306-LOI08

→  ${}^{28}\text{O}$  [Kondo] already done !

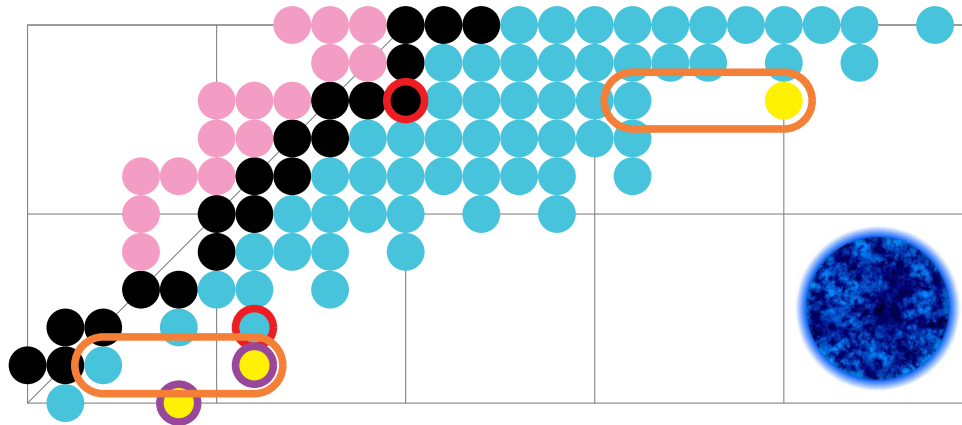

- $N = 6$  ( $\nu p_{3/2}$ )<sup>4</sup> sub-shell closure ?

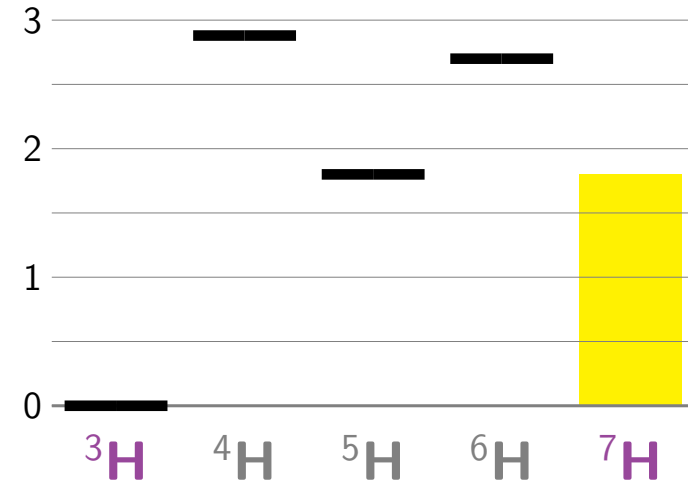

▶  ${}^8\text{He}(p,2p){}^7\text{H}$  @ 150 MeV/N :

*“Many-neutron systems:  
search for superheavy Hydrogen 7  
and its Tetraneutron decay”*

☞ Yang & FMM, RIBF NP1512-SAMURAI34

- follow up of ☞ Orr, RIBF NP1306-LOI08

→  ${}^{28}\text{O}$  [Kondo] already done !

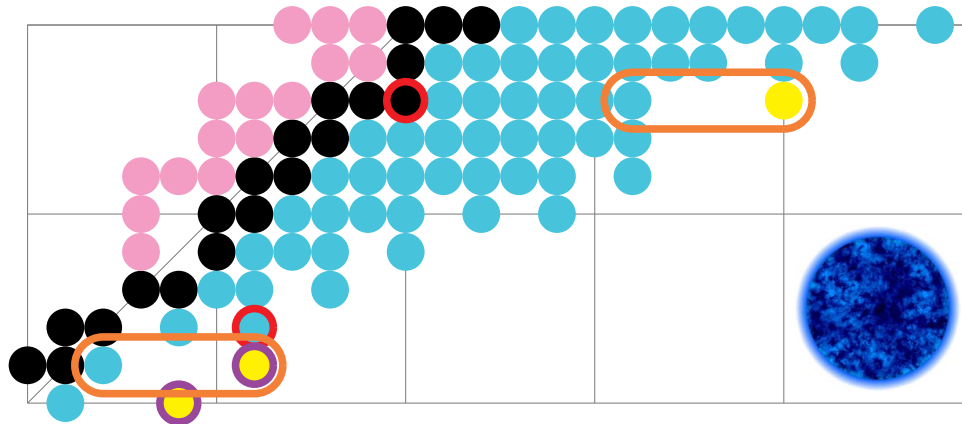

- $N = 6$  ( $\nu p_{3/2}$ )<sup>4</sup> sub-shell closure ?

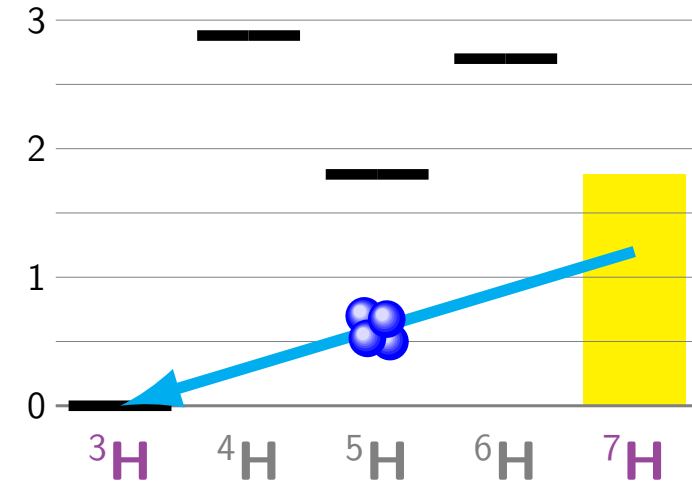

▶  ${}^8\text{He}(p,2p){}^7\text{H}$  @ 150 MeV/N :

*“Many-neutron systems:  
search for superheavy Hydrogen 7  
and its Tetraneutron decay”*

☞ Yang & FMM, RIBF NP1512-SAMURAI34

- follow up of ☞ Orr, RIBF NP1306-LOI08

→  ${}^{28}\text{O}$  [Kondo] already done !

- direct  ${}^4\text{n}$  decay ?  $E_R(4\text{n})$  !

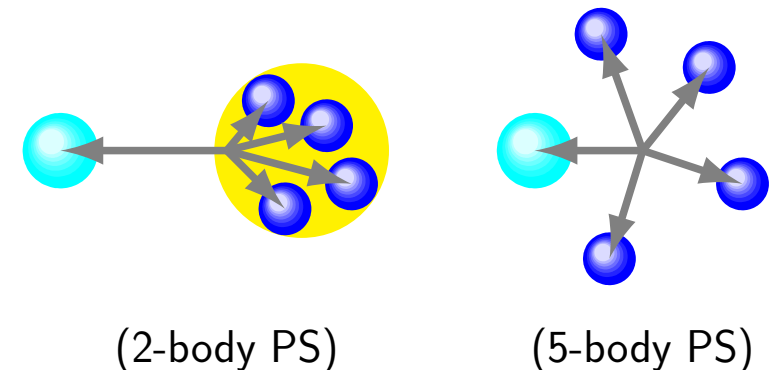



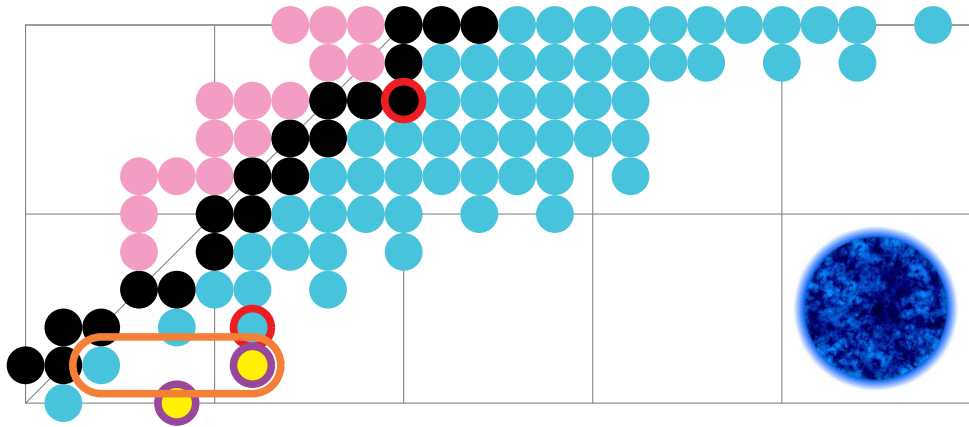

${}^8\text{He} (p, 2p) {}^7\text{H} @ 150 \text{ MeV/N} :$

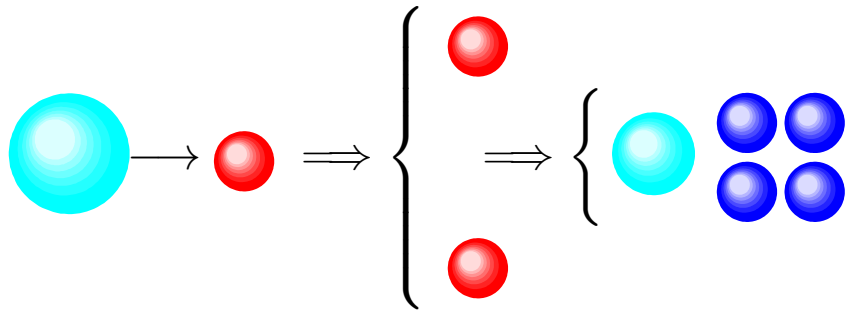

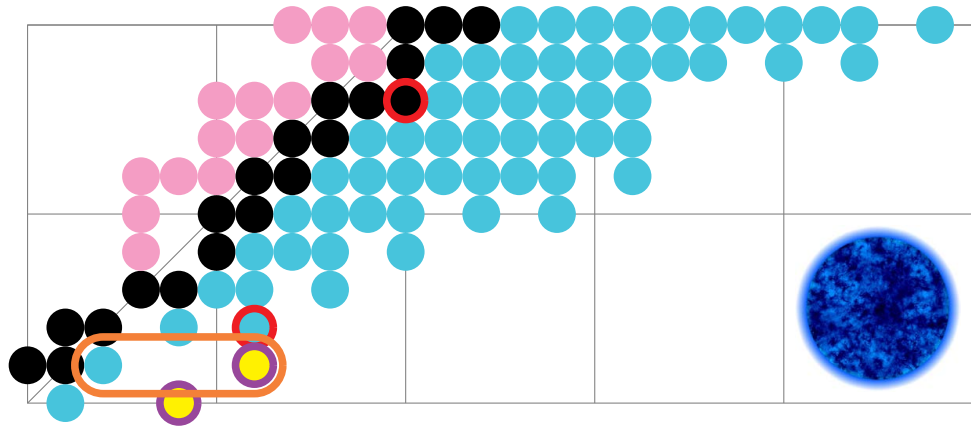

- **MINOS** liquid H target :
  - high luminosity (*statistics*)
  - proton angles (*resolution*)
- **DALI** NaI crystals :
  - proton energies (*efficiency*)
- **SAMURAI** :
  - triton momentum (*resolution & correlations*)
- **NEBULA + NeuLAND** :
  - 3/4 neutron momenta (*efficiency, resolution & correlations*)

${}^8\text{He} (p, 2p) {}^7\text{H} @ 150 \text{ MeV/N} :$

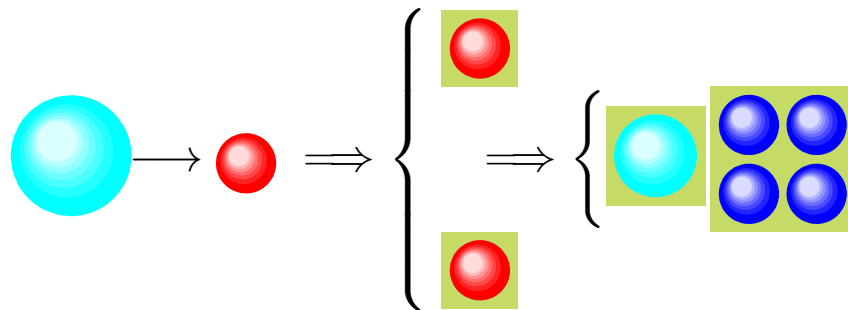

→ detection of the **7-body** final state !

$$\text{FWHM} \sim \begin{cases} 5 \text{ MeV} & (2p) \\ 150 \text{ keV} & (2p+t+3n) \\ 100 \text{ keV} & (t+4n) !!! \end{cases}$$

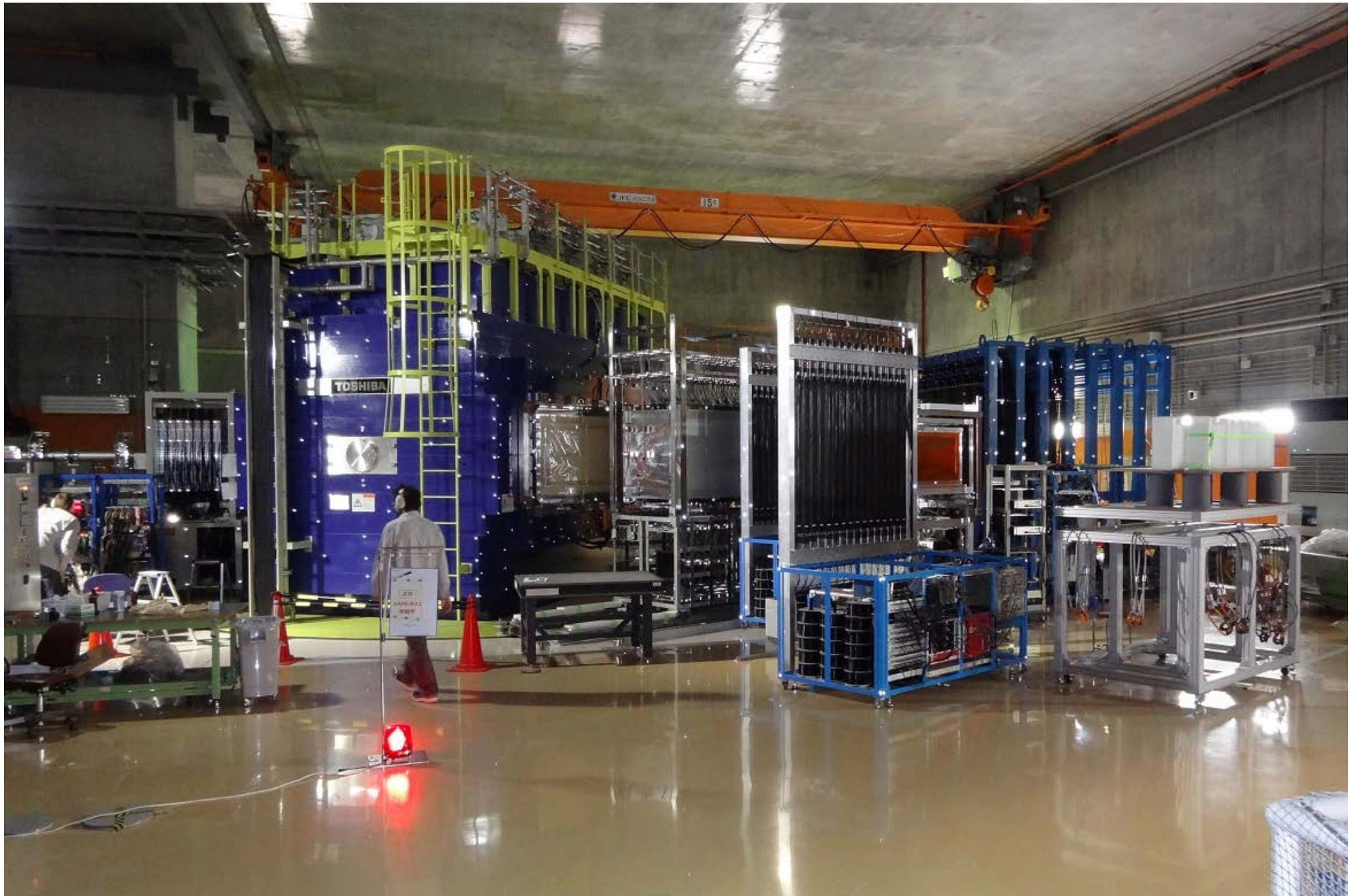





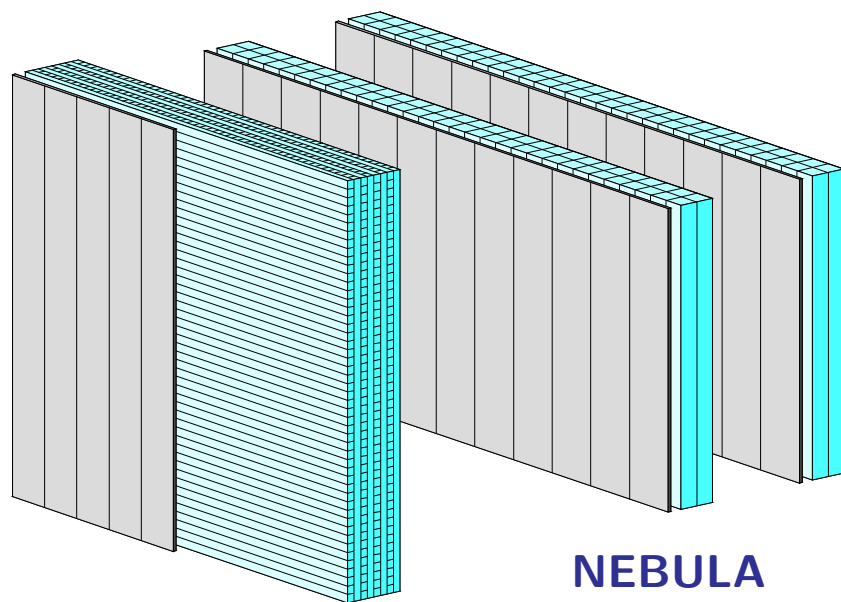
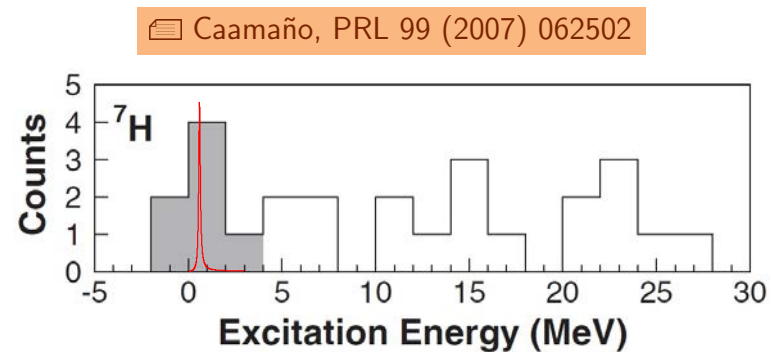
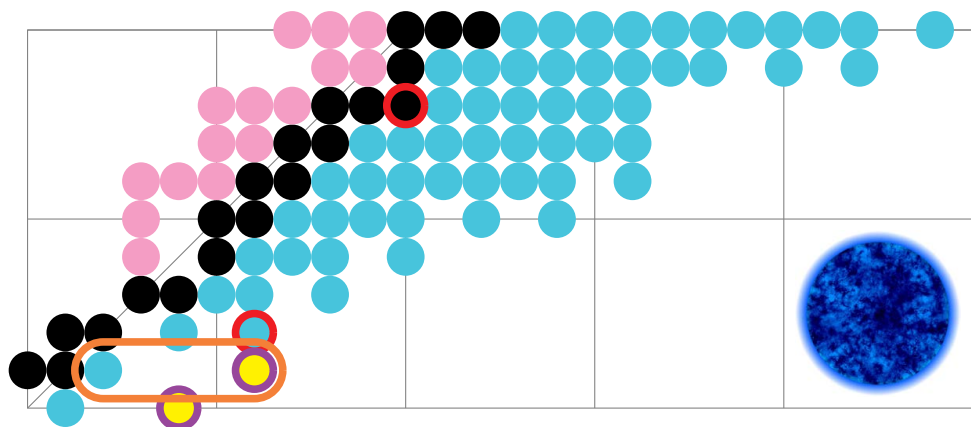

NeuLAND

NEBULA

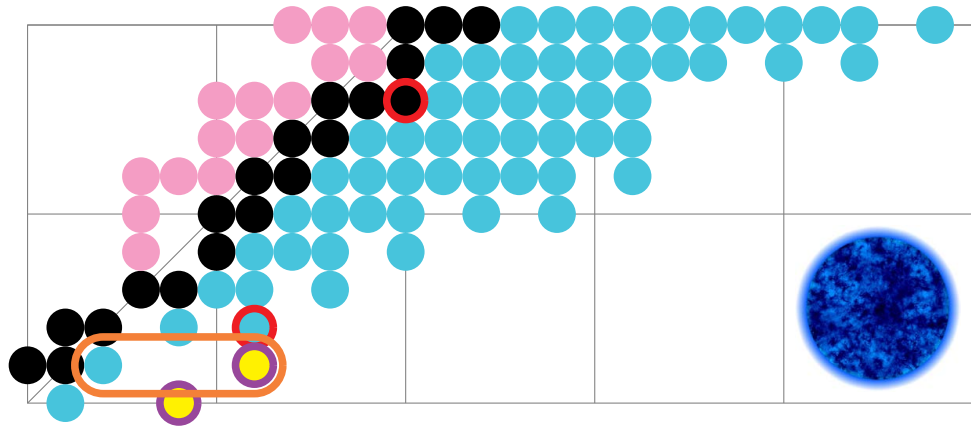

Caamaño, PRL 99 (2007) 062502

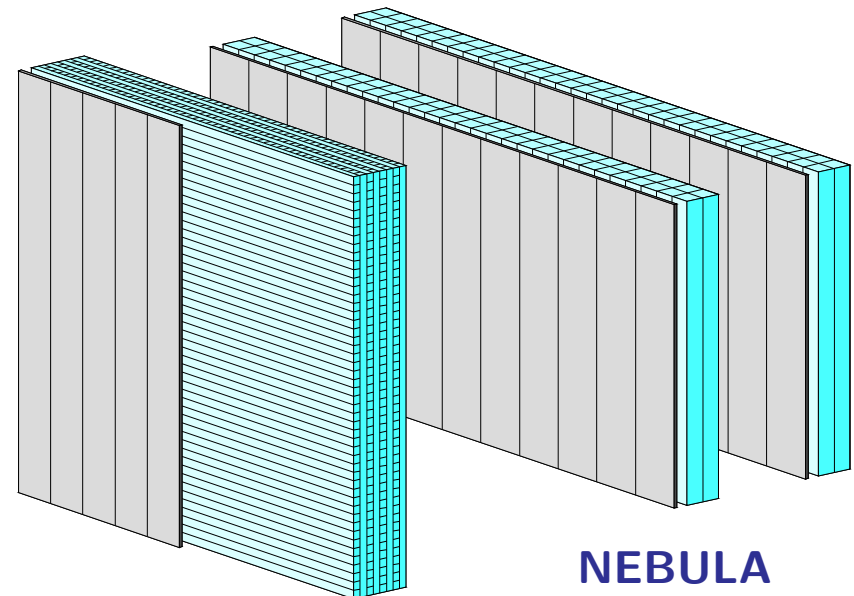
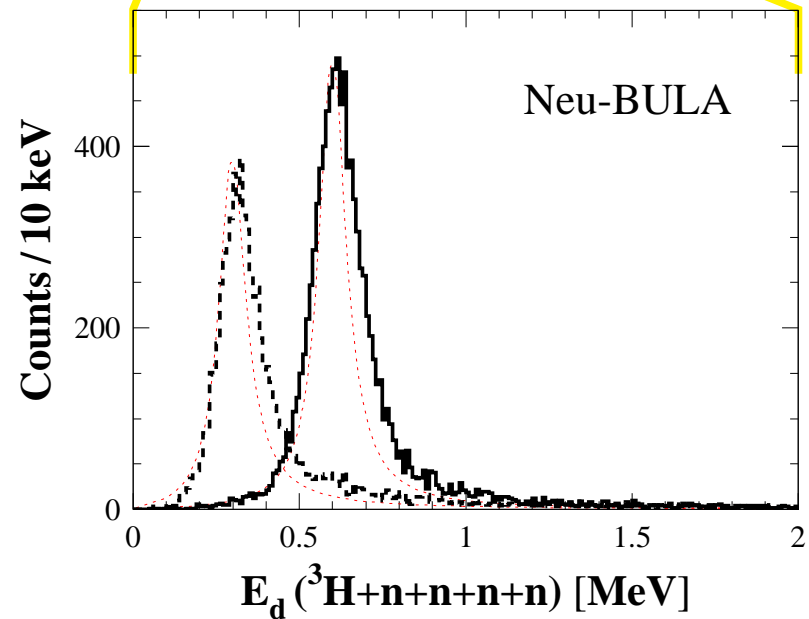
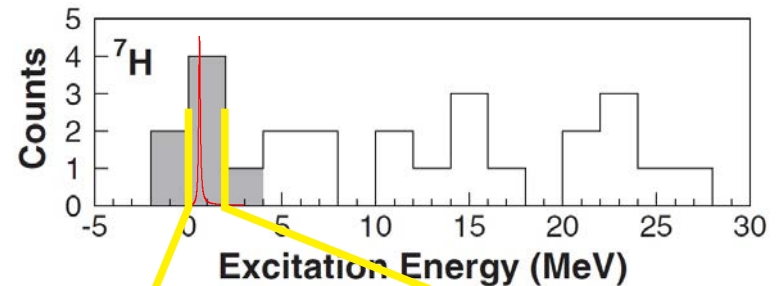

NeuLAND

NEBULA

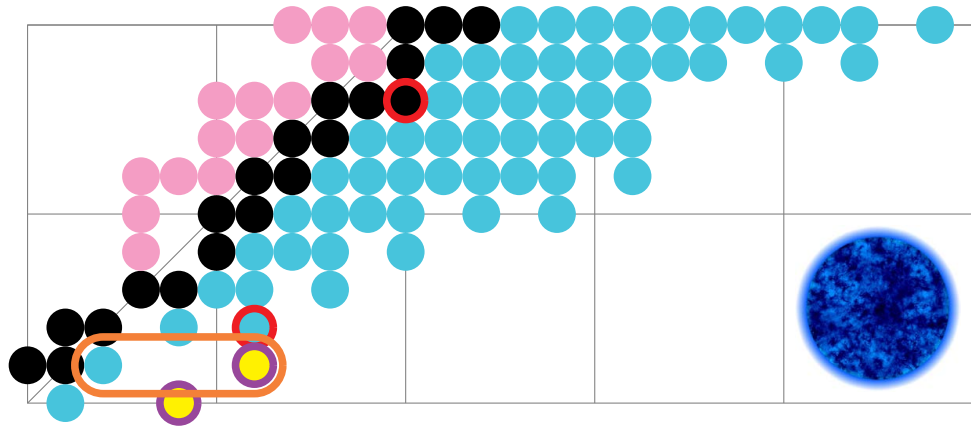

► Online analysis :  ${}^8\text{He} (p,2p) {}^3\text{H} + {}^4\text{n}$

✓  ${}^8\text{He}$  on target

✓ 2p detected

✓  ${}^3\text{H}$  detected

→  $\geq 4$  bars ?

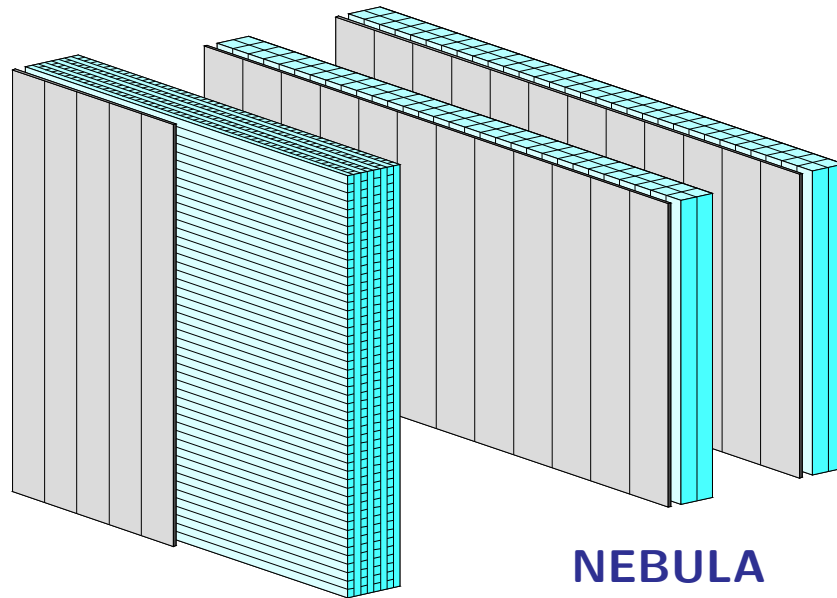

NeuLAND

NEBULA



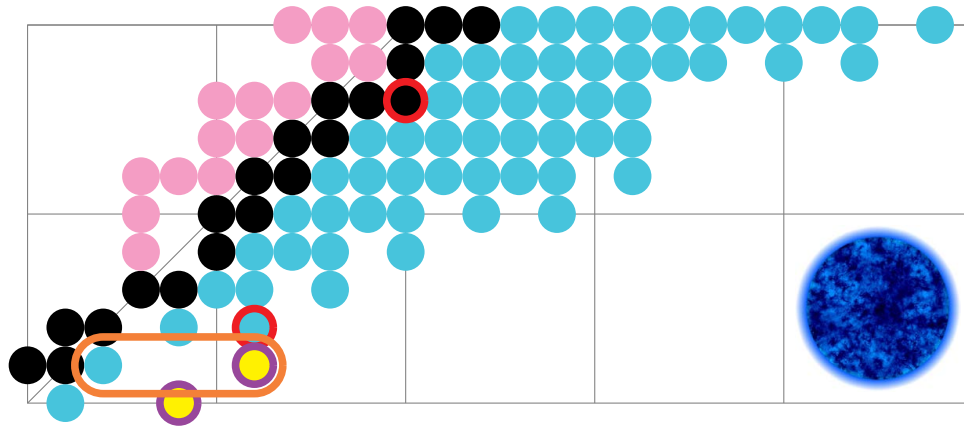

► Online analysis :  ${}^8\text{He} (p,2p) {}^3\text{H} + 4n$

✓  ${}^8\text{He}$  on target

✓ 2p detected

✓  ${}^3\text{H}$  detected

→  $\geq 4$  bars ?

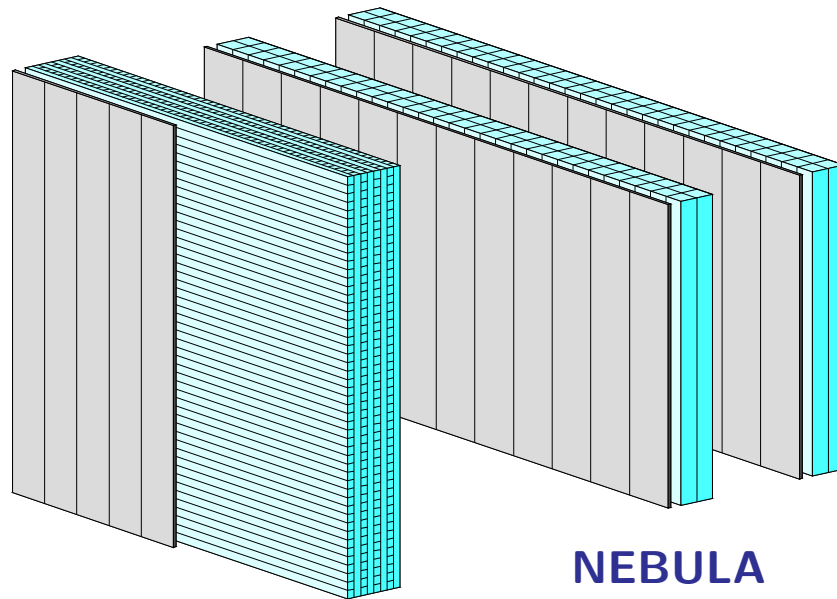

NeuLAND

NEBULA

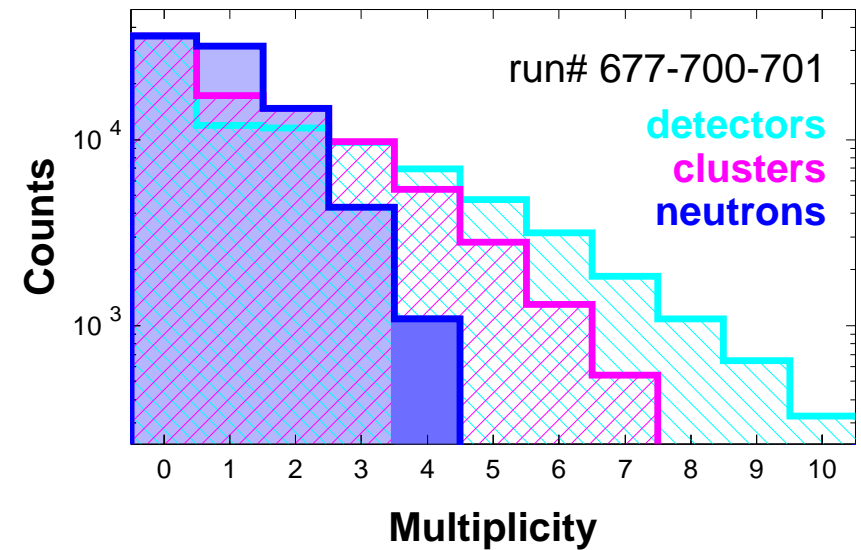

→ complete events :  $\approx 8 \times 10^4$  !!!

→ promising results in 1-2 years ...

## ① The $^A n$ context :

- XX century :  $\sigma(^A n)$  & backgrounds ...
- XXI century : first signals !
  - GANIL : theory & experiments
  - RIKEN : more candidate events
- experimental constraints
- theoretical 'proofs' ?

## ② The RIKEN campaign :

- SHARAQ 2.0 :  $^4\text{He} (^8\text{He}, \alpha\alpha) ^4 n$
- NEBULA+NeuLAND & MINOS :
  - $^8\text{He} (p, p\alpha) ^4 n$  : 4n without FSI
  - $^8\text{He} (p, 2p) \{^3\text{H} + ^4 n\}$  : any  $(E, \Gamma)_R$

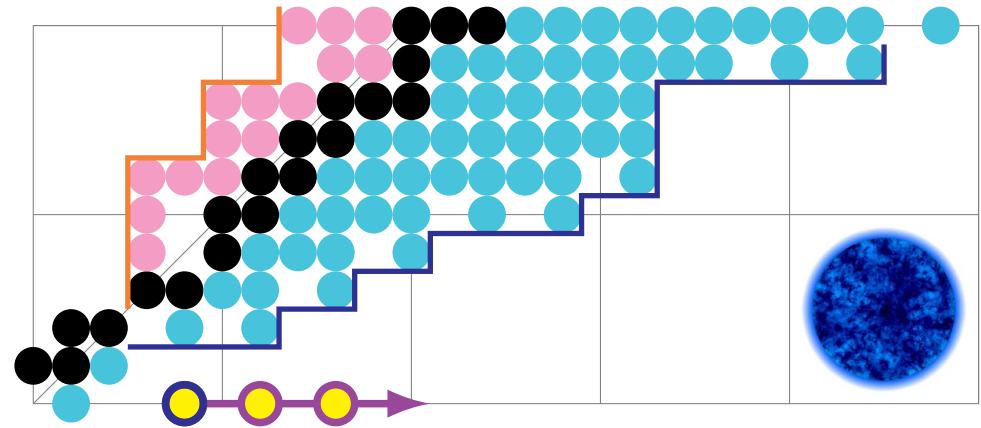

## ③ Short/Mid-term future :

- confirm (refute)  $^4 n$  signals !
- $^{12,14}\text{Be} (p, p2\alpha) ^{4,6} n$  ('18)
  - Beaumeil, NP1206-SAMURAI12
  - theory : reliable  $^4 n$  and beyond ...
  - hexaneutron ?  $^8\text{He} (p, 2p) ^1\text{H}$  ...
  - $^A n$  emission ?  $Q_{\beta 6n}(^{19}\text{B}) \sim 8 \text{ MeV}$  ...
  - core+ $xn$  systems/thresholds ?

► R3B collaboration (LAND @ GSI) :

- N = 12 isotones ( $^{18}\text{C}$  &  $^{20}\text{O}$ ) above  $S_{2n}$

Revel, submitted to PRL (2018)

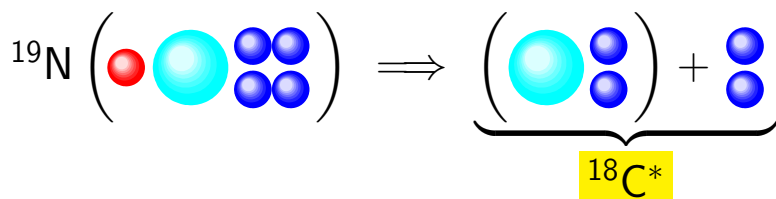
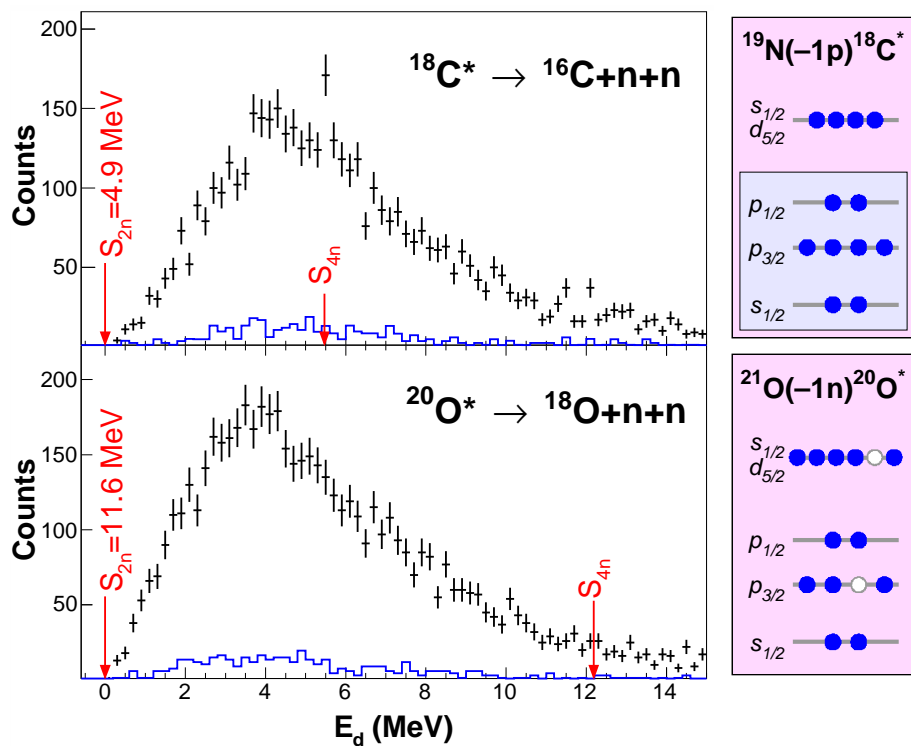

► R3B collaboration (LAND @ GSI) :

- N = 12 isotones ( $^{18}\text{C}$  &  $^{20}\text{O}$ ) above  $S_{2n}$

Revel, submitted to PRL (2018)

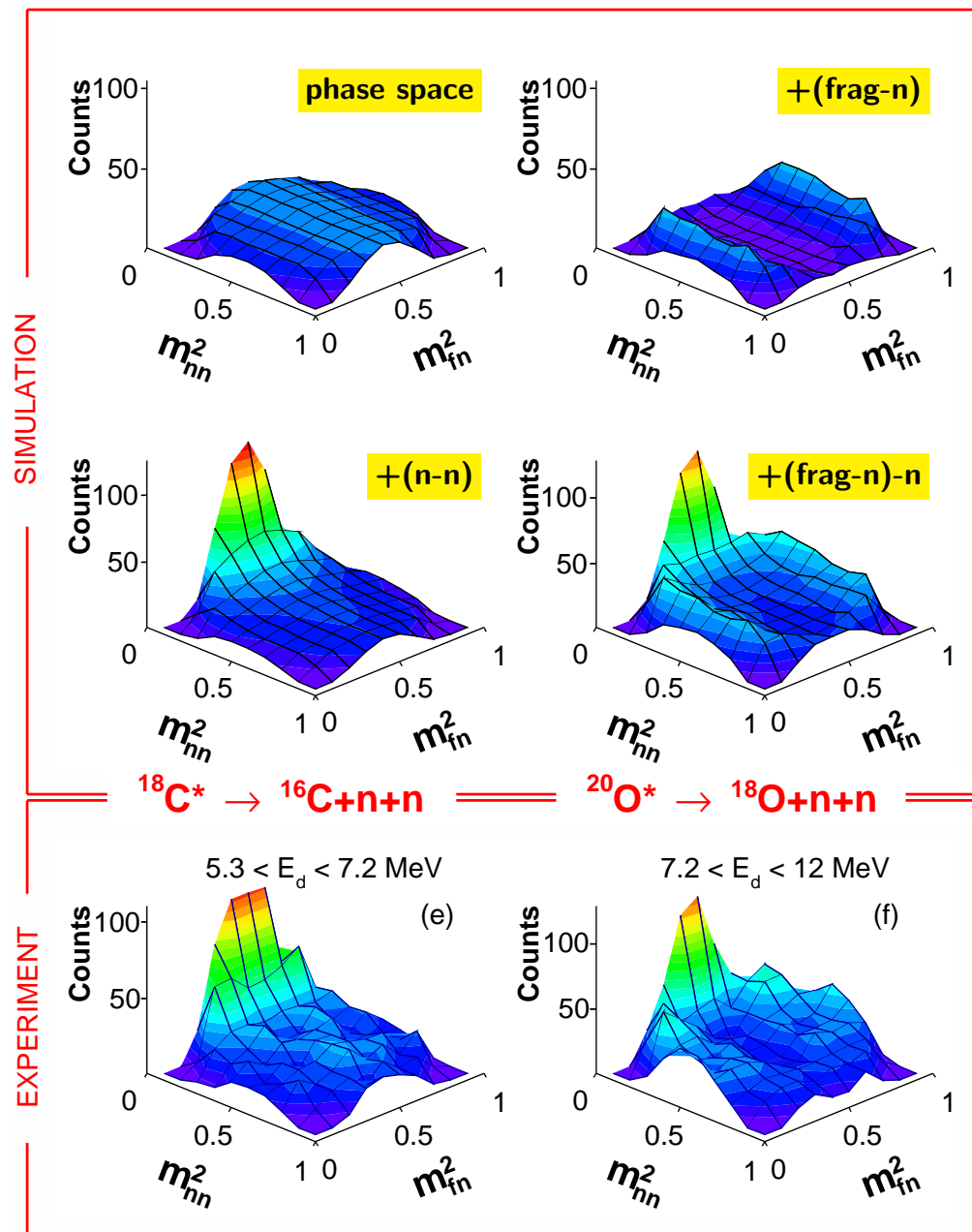
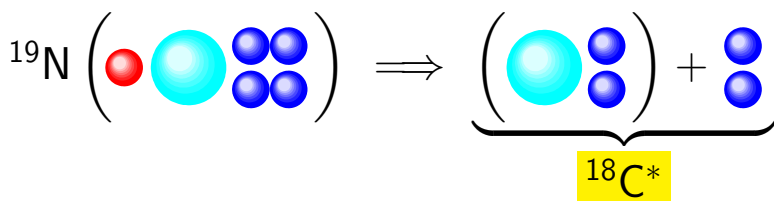
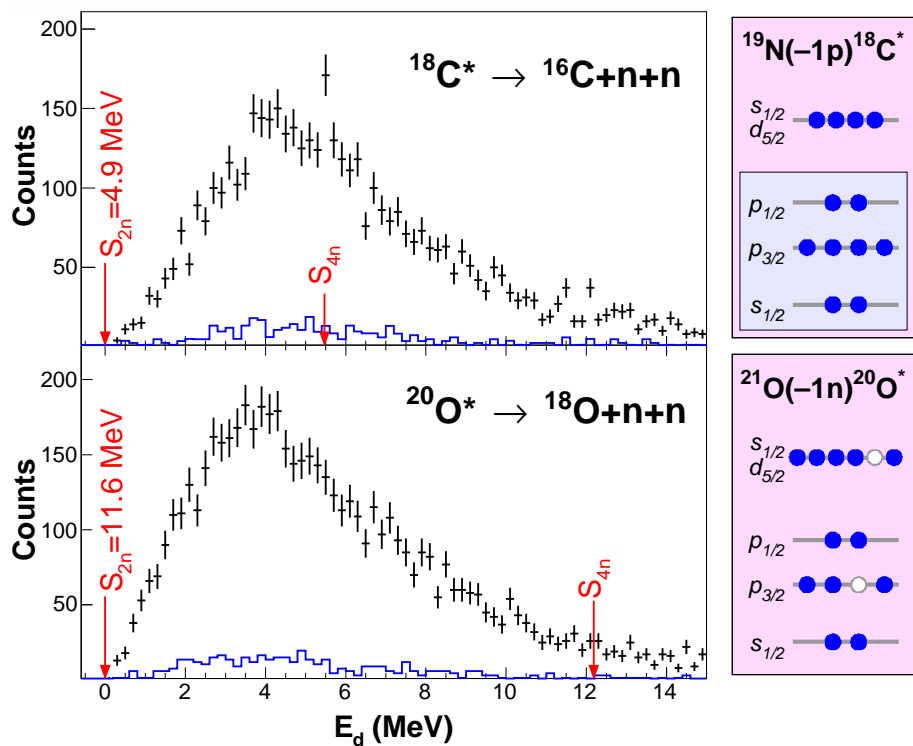

► R3B collaboration (LAND @ GSI) :

- N = 12 isotones ( $^{18}\text{C}$  &  $^{20}\text{O}$ ) above  $S_{2n}$

Revel, submitted to PRL (2018)

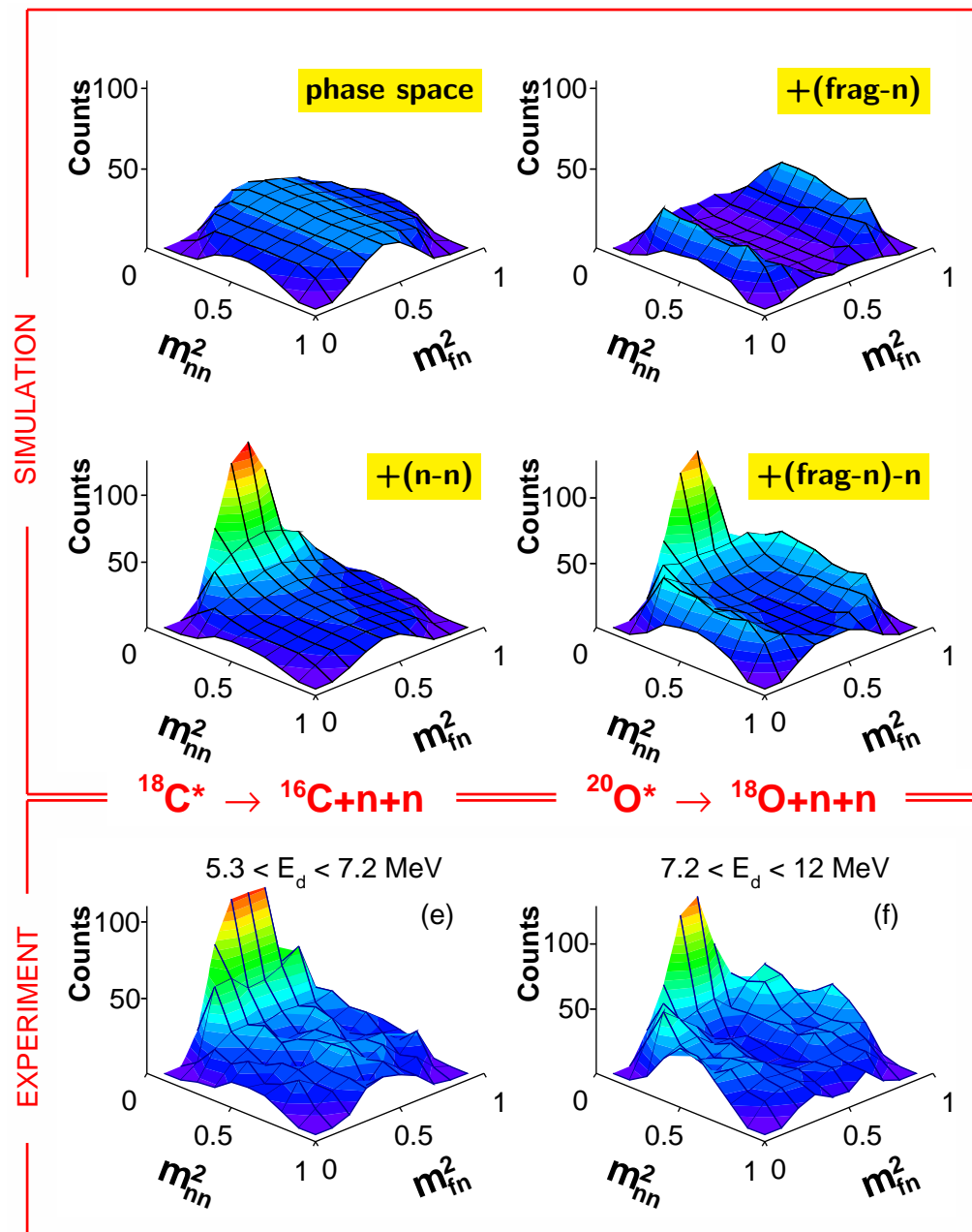
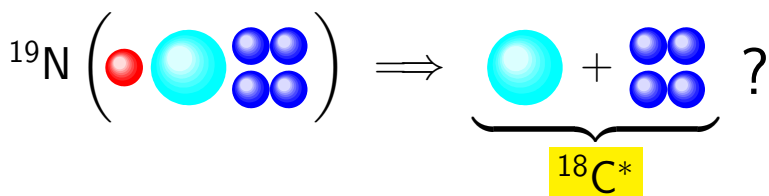
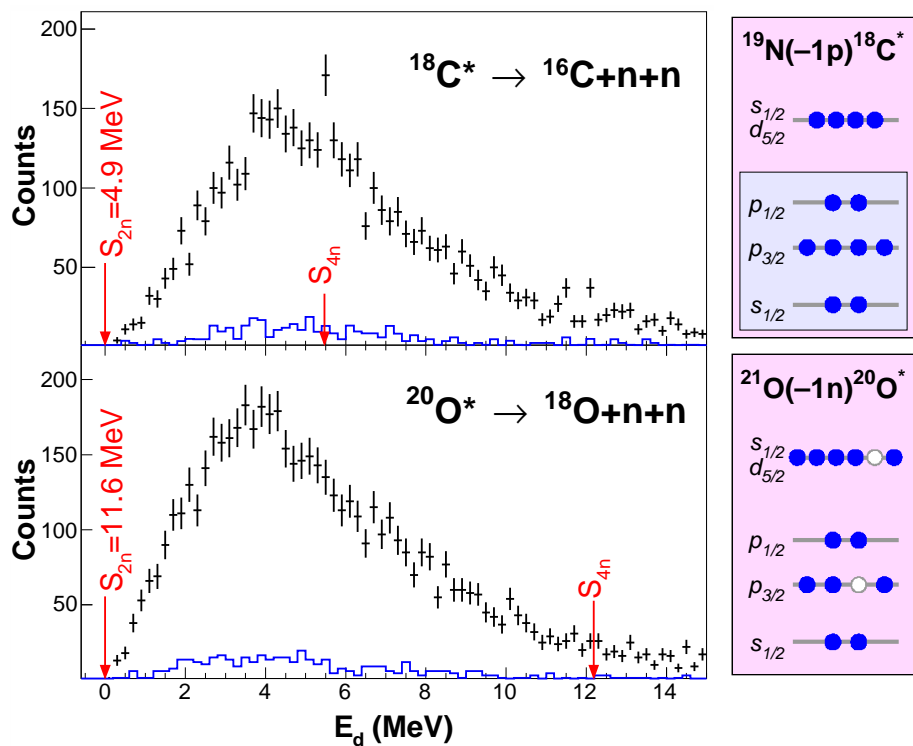

► Two-step reactions :

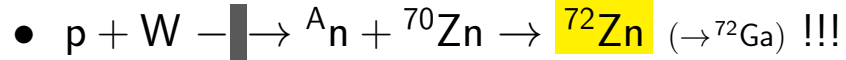

☞ Detraz, PLB 66 (1977) 33

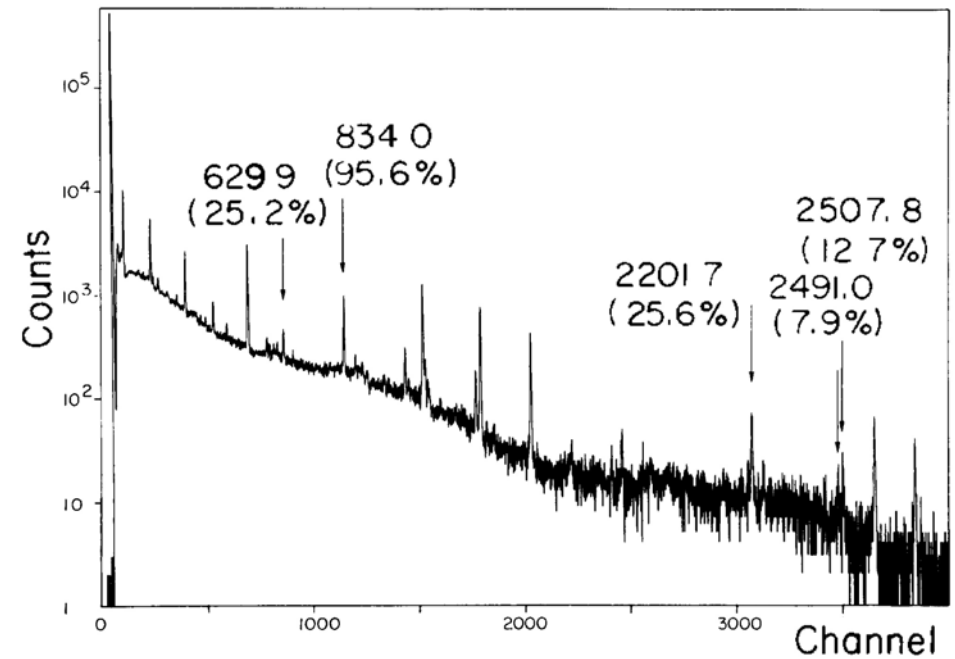
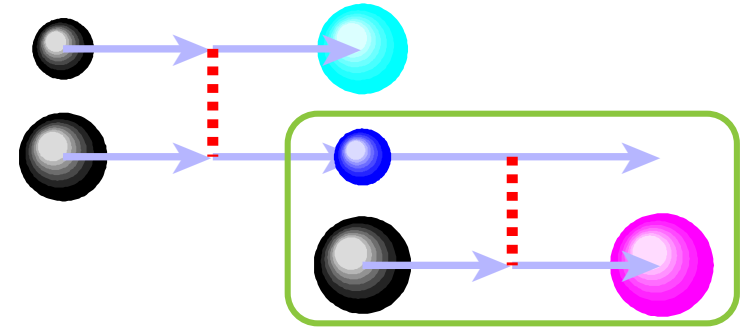

~~X~~  ${}^{70}\text{Zn}(t,p){}^{72}\text{Zn}$  through Aluminium ...

► **Two-step** reactions :

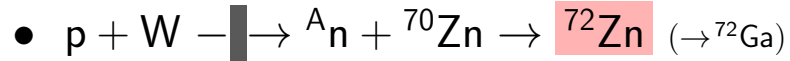

☞ Detraz, PLB 66 (1977) 33

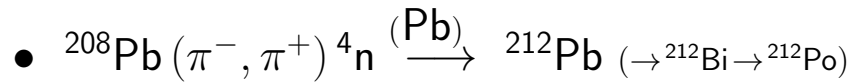

☞ Chultem, NPA 316(1979) 290

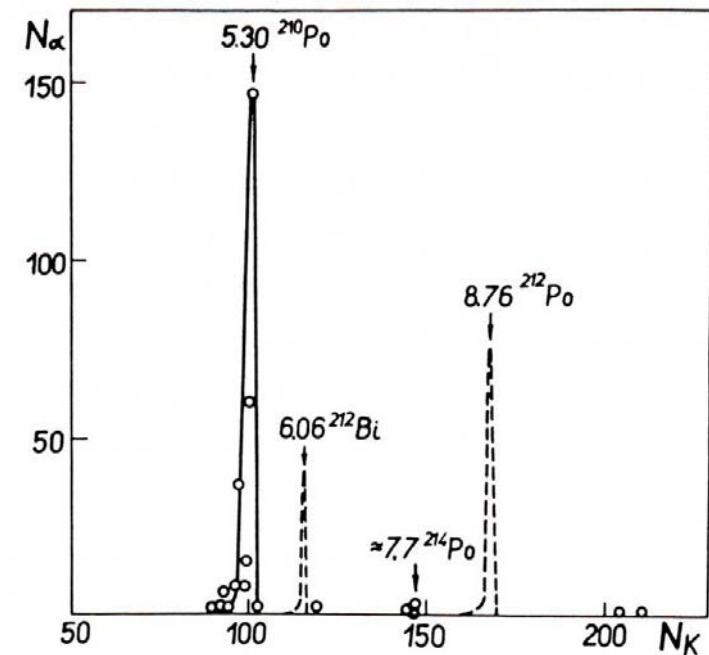
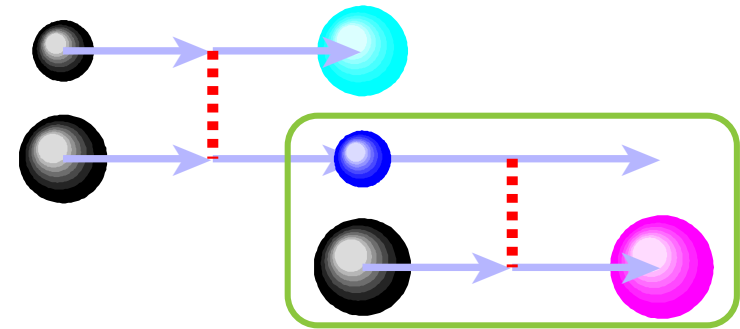

► **Two-step** reactions :

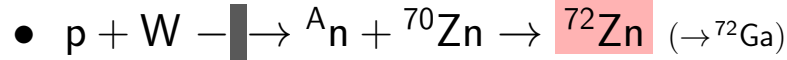

☞ Detraz, PLB 66 (1977) 33

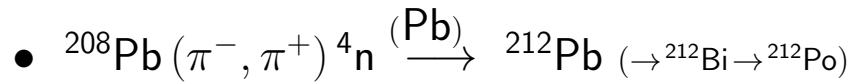

☞ Chultem, NPA 316(1979) 290

► Pion **charge-exchange** :

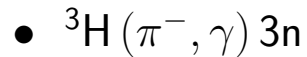

☞ Miller, NPA 343 (1980) 347

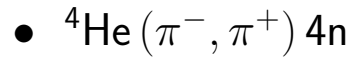

☞ Ungar, PLB 144 (1984) 333

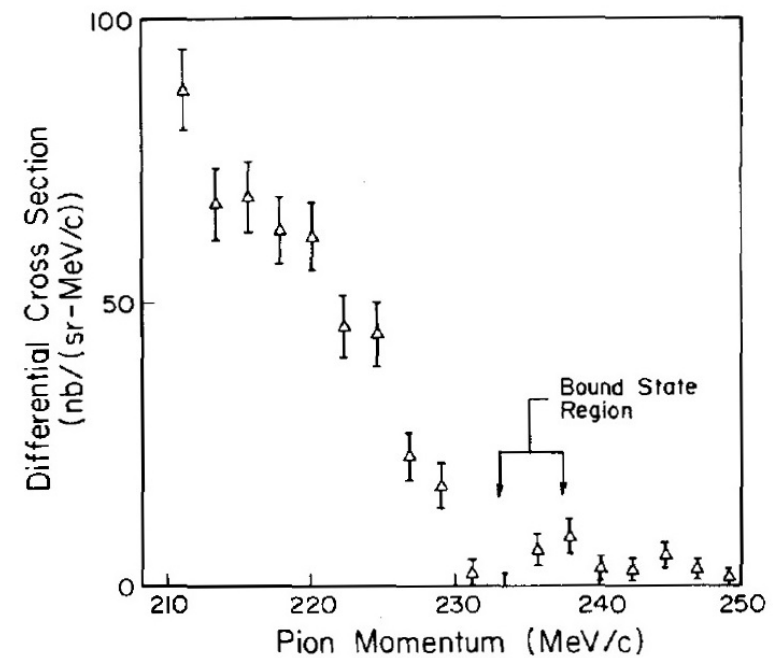
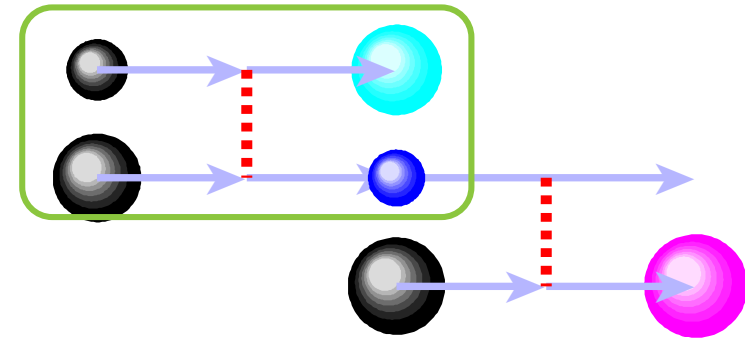



► **Two-step** reactions :

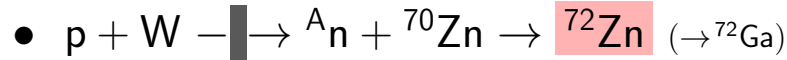

☞ Detraz, PLB 66 (1977) 33

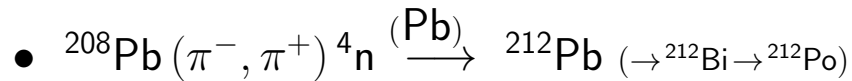

☞ Chultem, NPA 316(1979) 290

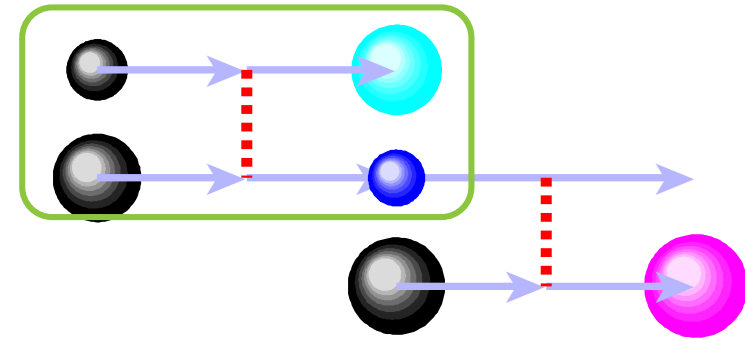

► Pion **charge-exchange** :

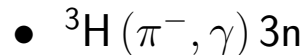

☞ Miller, NPA 343 (1980) 347

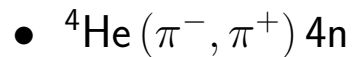

☞ Ungar, PLB 144 (1984) 333

► Multinucleon **transfer** :

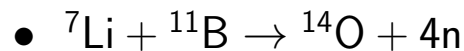

☞ Belozyorov, NPA 477 (1988) 131

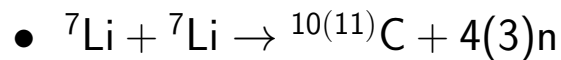

☞ Cerny, PLB 53 (1974) 247

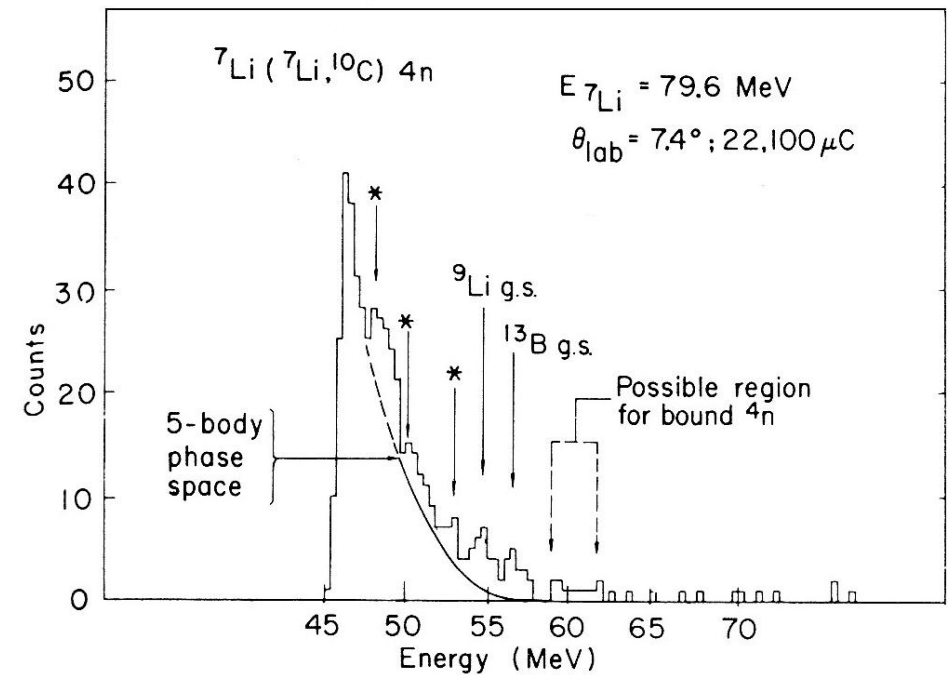

⇒ XX century : **cross-sections** & **backgrounds** ...

► **Two-step** reactions :

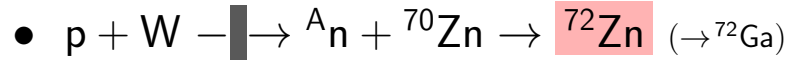

☞ Detraz, PLB 66 (1977) 33

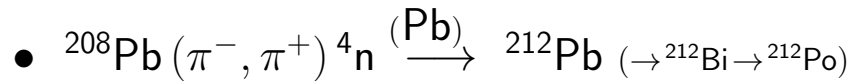

☞ Chultem, NPA 316(1979) 290

► Pion **charge-exchange** :

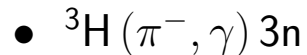

☞ Miller, NPA 343 (1980) 347

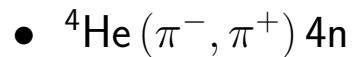

☞ Ungar, PLB 144 (1984) 333

► Multinucleon **transfer** :

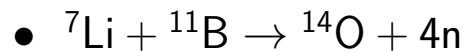

☞ Belozyorov, NPA 477 (1988) 131

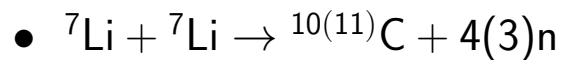

☞ Cerny, PLB 53 (1974) 247

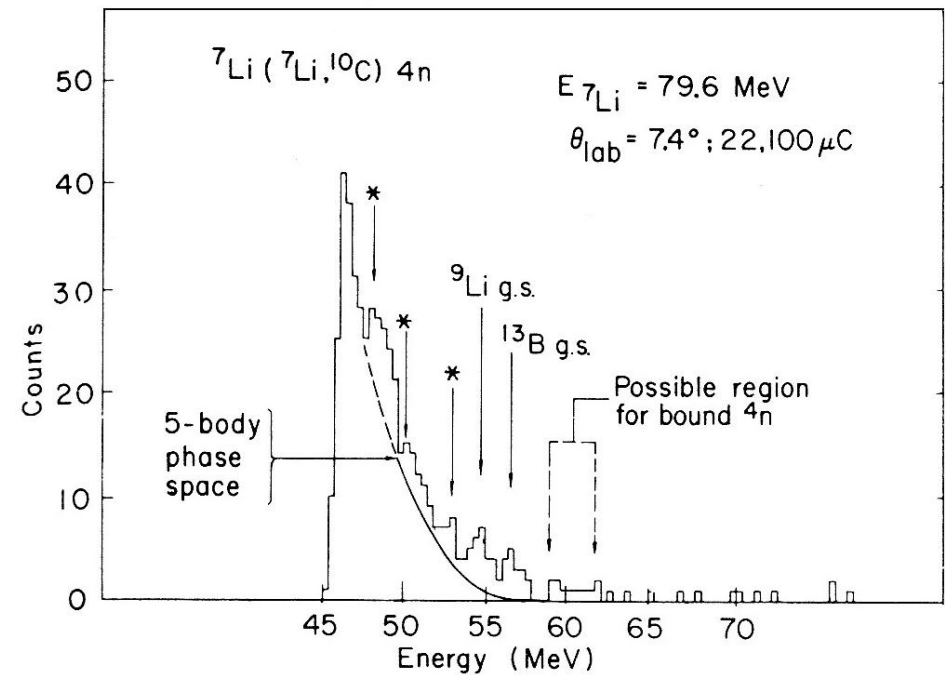
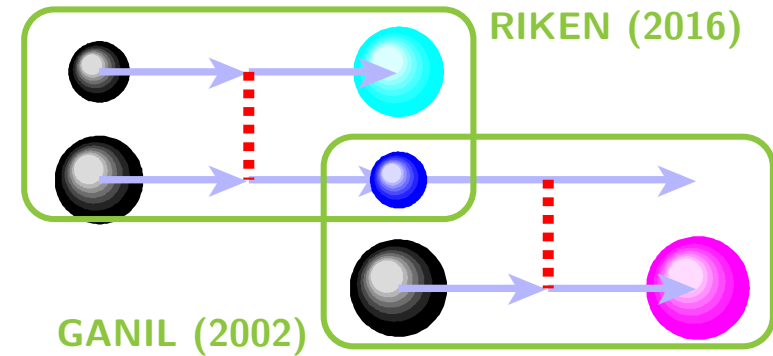

⇒ XX century : **cross-sections** & **backgrounds** ...

## Detection of Light Neutron Nuclei in the Alpha-Particle-Induced Fission of $^{238}\text{U}$ by the Activation Method with $^{27}\text{Al}$

B. G. Novatsky, S. B. Sakuta\*, and D. N. Stepanov

National Research Centre Kurchatov Institute, pl. Akademika Kurchatova 1, Moscow, 123182 Russia

\* e mail: sbsakuta@mail.ru

Received October 30, 2013

Light nuclear-stable multineutrons among products of the fission of  $^{238}\text{U}$  nuclei that is induced by 62-MeV alpha particles have been searched by the activation method with a  $^{27}\text{Al}$  sample. These multineutrons have been detected by characteristic gamma rays emitted by the nuclei from the beta-decay chain  $^{28}\text{Mg} \rightarrow ^{28}\text{Al} \rightarrow ^{28}\text{Si}$ . The  $^{28}\text{Mg}$  parent nucleus can be formed in the  $^{27}\text{Al} + x_n \rightarrow ^{28}\text{Mg} + p(x-2)n$  process. The gamma-ray spectra of the irradiated sample exhibit lines of 1342- and 1779-keV photons accompanying the beta decay of the  $^{28}\text{Mg}$  and  $^{28}\text{Al}$  nuclei, respectively. The decrease in the activity corresponds within the measurement accuracy with the half-life  $T_{1/2} \sim 21$  h of  $^{28}\text{Mg}$ , which **certainly indicates the detection of nuclear-stable multineutrons  $^x n$  with  $x \geq 6$ .**

### 1. INTRODUCTION

The problem of stability of nuclei consisting of neutrons only has long been actively studied both experimentally and theoretically. Interest in this problem is quite understandable, since the discovery of neutron nuclei would be revolutionarily important for nuclear physics and would radically change our representations on the nucleon–nucleon interaction with far-reaching consequences not only for nuclear physics but also for other fields of science, in particular, astrophysics. This discovery would be applied with the appearance of the possibility of the accumulation of neutron matter.

It is well known that two neutrons do not form a bound nuclear system. The overwhelming majority of experimental investigations indicate that the systems of three and four neutrons are also unstable.

Thus, the negative result of numerous searches for  $^{2n-4}n$  nuclei [5–9] does not exclude the existence of heavier neutron clusters.

### 2. DESCRIPTION OF THE EXPERIMENT

The primary target (a  $^{238}\text{U}$  foil 160  $\mu\text{m}$  thick) placed at the center of a scattering chamber was bombarded with a beam of 62-MeV alpha particles accelerated at the cyclotron of the Kurchatov Institute.

An aluminum sample with a mass of 2.8 g was placed in a hermetically sealed container installed in a vacuum scattering chamber at an angle of  $20^\circ$  with respect to an incident alpha-particle beam. An additional beryllium filter 1 mm thick was placed upstream of the aluminum sample in order to suppress the background of scattered alpha particles, tritons from the  $^{238}\text{U}(\alpha, t)$  reaction, and other charged particles. In view of a high activity in the room, the irradiated samples were transported and processed half an hour after irradiation.

In this case, the intense 1368- and 2754-keV gamma lines of the  $^{24}\text{Na}$  isotope from the  $^{27}\text{Al}(n, \alpha)^{24}\text{Na}$  ( $Q=3.13$  MeV) reaction and the corresponding Compton background are the only factors hindering the reliable identification of gamma rays from the chain of nuclei  $^{28}\text{Mg} \rightarrow ^{28}\text{Al} \rightarrow ^{28}\text{Si}$ .

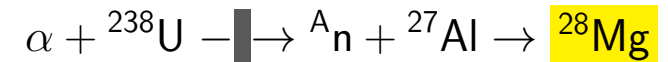
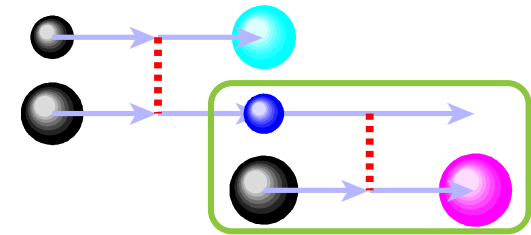

$\Rightarrow A > 1$  : but only **6/8n** can exist !

### 4. CONCLUSIONS

To conclude, nuclear-stable multineutrons among products of the ternary fission of  $^{238}\text{U}$  nuclei that is induced by 62-MeV alpha particles have been sought by the activation method.

The reported measurements confirm the results of our previous work [10], where the possible emission of multineutrons from the ternary fission of  $^{238}\text{U}$  was established by characteristic 1384-keV gamma rays from the  $^{88}\text{Sr} + x_n \rightarrow (x-4)n + ^{92}\text{Sr} \rightarrow ^{92}\text{Y}$  process in the activated strontium sample. Comparison showed that the yield of  $^{28}\text{Mg}$  in the case of the interaction of multineutrons with  $^{27}\text{Al}$  is an order of magnitude higher than the yield of  $^{92}\text{Sr}$ .

The results of two independent experiments indicate that nuclear-stable multineutrons (most likely,  $^6n$ ) are emitted from the alpha-particle-induced ternary fission of  $^{238}\text{U}$ . In the future, we are going to improve the statistics of the measurements by increasing the intensity of the beam and irradiation time of sample.