

Sir George Cayley: The Invention of the Aeroplane near Scarborough at the Time of Trafalgar

J. A. D. Ackroyd

Former Aerospace Division
Manchester School of Engineering
The Victoria University of Manchester
Manchester, UK

Abstract

After a brief biography which outlines Cayley's wide range of activities, the paper concentrates on his work with the aeroplane. Beginning with his invention of the aeroplane concept, the paper describes the evolution of his thinking and his practical applications of it. Attempts are made to estimate the performance of the aeroplanes he built.

1.0 INTRODUCTION

The bicentenary of the invention of the concept of the aeroplane by the Yorkshire baronet, Sir George Cayley (1773-1857), occurred in 1999. The year 2004 saw the bicentenary of two further major achievements by Cayley, namely the first measurement of wing lift and, more dramatically, the flight of the world's first aeroplane. Both advances occurred in the year before Trafalgar and, like the invention itself, took place near the Yorkshire coastal town of Scarborough. However, in the year 2003 we celebrated the centenary of that tremendous achievement, the first powered, controllable flights by the Wright brothers. Thus during the early years of the new millennium we celebrated massive aeronautical progress, yet this close conjunction of dates suggested the possibility that Cayley's achievements might become overshadowed by those of the Wrights. This was the stance taken by the current author in delivering the 46th Cayley Lecture to the Society's Brough Branch in April 2000. The full text of the paper upon which that Lecture was based was not published although a severely abridged version⁽¹⁾ appeared in 2002. Now, with the advent of the *Journal of Aeronautical History*, it is possible to present the paper's complete text, updated.

The Wrights themselves were in no doubt as to Cayley's importance. In 1909 Wilbur Wright is reported⁽²⁾ as saying:

“About 100 years ago an Englishman, Sir George Cayley, carried the science of flying to a point which it had never reached before and which it scarcely reached again during the last century.”

This paper is based on the 46th Cayley Lecture at the Society's Brough Branch in April 2000.

At that time, however, the Wrights could have been aware of only a limited amount of Cayley's work. A far greater indication of Cayley's stature did not begin to emerge until 1926 when the first of his aeronautical notebooks was discovered at the family seat, Brompton Hall, by this Society's Librarian, John Hodgson. This he reviews in Refs. 3 and 4. A further collection emerged from the same source in 1961 and this is included in Gibbs-Smith's⁽²⁾ extensive survey of all the then-known material. In a later paper Gibbs-Smith⁽⁵⁾ briefly revisits much of this, but his concern here is mainly to emphasise Cayley's stature and influence on subsequent developments in aeronautics. His invaluable studies^(2, 5) provided the basis for the review of Cayley's aeroplane work included in the video series of Ref.6. In addition there is Sproule's⁽⁷⁾ description of his experience of building and flying replicas of Cayley's gliders. Regrettably, however, he makes virtually no comparison with such performance figures as Cayley has left to us. More photographs of his Cayley glider replicas can be found in Ref. 8, these kindly supplied by Michael Oakey, then editor of *Aeroplane Monthly*, and his staff.

As to Cayley himself and his other activities, what is known is perhaps rather less than one might wish for. Some of the more important material that survives provided the basis for the first Cayley Memorial Lecture⁽⁹⁾ presented before the Society's Brough Branch in November 1954, an event happily coinciding with the Branch's 25th anniversary celebration. The Lecture was presided over by that other Yorkshire name famous in aviation, Robert Blackburn, and presented by Laurence Pritchard, the great authority on Cayley's life and for many years the distinguished Secretary of this Society. Pritchard's lecture offers a preview of his far more extensive and intriguing biography⁽¹⁰⁾, which attempts to cover the full range of Cayley's multifarious activities. In contrast, Fairlie and Cayley⁽¹¹⁾ concentrate more on his domestic circumstances, the second author having access to family papers as the wife of Sir Kenelm Cayley, the last baronet directly descended from Cayley. To this the booklet by Rivett and Matthew⁽¹²⁾ and the recent biography by Dee⁽¹³⁾ add information more recently come to light. On this basis the next section attempts a brief biography in which Cayley's major achievements, not solely with the aeroplane, are emphasised. What emerges is a man of high intelligence blessed with inventive genius, all this coupled to a disposition notably humane for its time.

As to Cayley's technical data, and indeed his scientific arguments in general, in certain respects there has been a tendency to avoid detailed study of their meaning whilst ascribing a significance to them which may be beyond their value. There can be, of course, no doubt as to Cayley's immense importance and stature, yet it does no service to this man to claim for him more than his due. Thus the present paper attempts to avoid ritual genuflection in favour of an assessment of the progress of Cayley's thinking on the aeroplane and the extent to which he saw his invention in the round. With such an aim in view, this assessment intends to lean rather more to the technical than hitherto attempted.

2.0 BIOGRAPHICAL SKETCH

George Cayley (Figure1) was born in the Yorkshire coastal town of Scarborough on December 27th, 1773. His precise place of birth seems still to be a subject of debate.

Pritchard⁽¹⁰⁾ has him born in Paradise House (Figure 2) - the event now having the official blessing of a blue plaque there - close to the old Parish Church of St Mary's with its grave of Anne Brontë. Fairlie and Cayley⁽¹¹⁾, however, place the event somewhere within the



Figure 1 Sir George Cayley. Portrait by Henry Perronet Briggs, RA. 1840 (© National Portrait Gallery, London).



Figure 2 Paradise House, Scarborough. (Author's Collection)

presently the site of Lloyds Bank on St Nicholas Street. Since the scene of this declaration was a hustings meeting at which Cayley stood, successfully, for Parliament, his statement may have been no more than a rhetorical flourish ("I am one of you") but, if literally true, this places his birth nearly a half-mile from the Paradise district.

surrounding Paradise district. Local historians, in contrast, point to Cayley's own statement of 1832 (see Refs.10 and 11) that he was born "within a hundred yards of" the steps of the then Scarborough Town Hall,

His home during his early years seems to be equally unclear. Pritchard⁽¹⁰⁾ believes this to have been at Helmsley, some thirty miles due west of Scarborough, whereas Ref.11 has him growing up at The Green, a sizeable house at the edge of the village of Brompton-by-Sawdon. This village lies some eight miles south-west of Scarborough on the Pickering road and it is here that Cayley's major achievements in aeronautics took place.

Cayley's mother, born Isabella Seton (c1745-1828), was a Scotswoman of education and intelligence whose determined views ensured her son's lively instruction in areas not merely those marked out as necessary for a young gentleman destined for a high place in society. Given her son's evident enthusiasm for all things mechanical, Isabella Cayley ensured that the then unusual subjects of mathematics and the physical sciences were central to his curriculum. In 1763 she had married George's father, Thomas Cayley (1732-1792), the son of the fourth baronet in the Cayley line. The latter was resident at Brompton Hall (Figures 3a and 3b), the centre of the family estates at Brompton-by-Sawdon. Thomas's father being long-lived, whereas Thomas himself endured indifferent health, Thomas did not succeed to the baronetcy and Brompton estates until a mere eighteen months before his own death. Thus, at the early age of nineteen, in 1792 George Cayley became the sixth baronet whilst in the closing stages of his formal education.



Figure 3a Brompton Hall.
(Author's Collection)



Figure 3b Brompton Hall.
(Author's Collection)

George Cayley's dire experience of a fever whilst attending board school in York seems⁽¹¹⁾ to have provided the spur for his mother's re-arrangement of his education. Henceforth he was to lodge with private tutors, firstly in Nottingham, then at Southgate some seven miles north of central London. Thus in 1791 he lived with his Nottingham tutor, George Walker FRS (1734-1807), a distinguished mathematician and nonconformist minister, a man, moreover, noted for his reforming zeal – particularly for social and parliamentary reform – and active in his support for the independence of the American colonies. Walker had one child, a daughter Sarah, who joined his lodgers in the role of tutee. Two years Cayley's senior, mathematically accomplished and notably attractive, Sarah Walker (c1771-1854) soon provided significant distraction for the young man. It seems⁽¹¹⁾ that for this reason Isabella Cayley, disapproving of Sarah, moved her son to Southgate, there to be tutored by George Cadogan Morgan (1754-1798), also a nonconformist and distinguished lecturer on such subjects as mechanics and electricity at Hackney College, London.

Both Walker and Morgan had considerable influence on the young Cayley, and not only in the areas of mathematics and the physical sciences. Moreover, his residence in Southgate provided opportunity for him to move in London's circle of reformers. However, in 1792, after his move to Southgate earlier that year, he succeeded his father as baronet and, within a year of attaining his majority, in 1795 married Sarah Walker. The union was to produce nine children, six daughters and three sons, two of the sons succumbing to a measles epidemic in 1813, whilst one daughter died around 1819 in Paris of heart disease, aged sixteen. By all accounts^(10, 11), the marriage proved to be a turbulent one. The new Lady Cayley was possessed of a temper sufficiently ungovernable to leave her children in a state of shock and Sir George writing to friends and neighbours in apology for his wife's behaviour⁽¹¹⁾. Yet her death in 1854 left Sir George desolate, notwithstanding the fact that, in her later years, it had proved advisable to put her into the temporary care of a certain Mrs Crowther of York. As one daughter wrote⁽¹¹⁾ to another at the time,

“Her teasing of Papa is beyond what any saint could be expected to bear.”

According to Ref.11, his cousin, Philadelphia Frances Cayley (c1777-1858), provided some mitigation of Sir George's difficult domestic circumstances. Four years his junior, resident

at the nearby Low Hall, Brompton, she outlived him by a year. Largely unbeknown to Sir George, she appears⁽¹¹⁾ to have carried a torch for him throughout her life. A more distant relative, Arthur Cayley FRS (1821-1895), was elected the first Sadlerian professor of pure mathematician at Cambridge in 1863.

This, then, was the background of the man who brought the aeroplane concept into being. By 1961 Pritchard⁽¹⁰⁾ was in no doubt that Cayley could claim the aeroplane's invention and in the following year Gibbs-Smith⁽²⁾ agreed. Indeed, he cited other authorities who had already reached that conclusion, including Hodgson and the eminent French aviation historian, Charles Dollfus. Earlier, in 1954, Theodore von Kármán had put the case as follows⁽¹⁴⁾:

“Thus the principle of the airplane as we know it now, that of the rigid airplane, was first announced by Cayley.”

With all such opinion, this author entirely concurs.

For brevity's sake, listed below is a chronology of some of the more notable events which placed Cayley before the public eye (items in italics will be discussed in more detail later).

- 1799** a) *First entries in his Aeronautical and Miscellaneous Notebook.*
b) *Engraving of a silver disk, now at the Science Museum, London.*
- 1800** His presentation to Parliament initiating the Muston Drainage Act. He is appointed first Chairman of the Muston Drainage Scheme. Later he became a leading authority on land drainage. On the grounds of age, he resigned his directorship of the Muston Scheme in 1853. Muston lies about a mile west of Filey but the scheme involved draining large tracts of land adjoining the Derwent-Hertford river, the former stretch passing about one mile to the south of Brompton.
- 1804** *Notebook descriptions of his whirling arm and model glider experiments.*
- 1805** The first major landowner to initiate a system of agricultural allotments, giving one acre of tillage land to labourers at Brompton.
- 1807** a) Notebook entry on a gunpowder engine (Figure 4). Harvey's "best gunpowder" falls down the tube from the small conical hopper on the left so as to be ignited by the lamp flame. The gases pass into the lower cylinder and through an upper vent so as to push the piston in the upper cylinder. The bow's spring returns the piston.
b) Description of a hot air engine (Figure 5) (Nicholson's Journal). Air is driven from the lower cylinder by the descending lower piston so as to pass through the burning fuel in the cylinder to the right. The heated air is then fed, alternately, to each side of the upper cylinder's piston.
- 1808** a) *Invention of the tension wheel.*
b) *A further glider.*
- 1809** a) *The solid of least resistance.*
b) *First part of a paper on Aerial Navigation dealing with the aeroplane (Nicholson's Journal).*

- 1810** *Second and third parts of the paper on Aerial Navigation by aeroplane (Nicholson's Journal).*
- 1816** First and second papers on the airship (Figures 6 and 7) (Tilloch's Philosophical Magazine). Since weight and air resistance increase as the square of linear dimensions, whereas the lifting force increases as the cube, Cayley argues for airships of large size. To reduce resistance, the envelope is to be elongated as shown. The lifting gas is to be either heated air or hydrogen. Thrust is to be provided by flappers.
- 1817** Third paper on the airship (Figure 8) (Tilloch's Philosophical Magazine). Thrust is to be supplied by flappers or, alternatively, by propellers.
- 1818** a) *Letter to Lord John Campbell describing a new glider.*
b) Pamphlet on Parliamentary Reform.
- 1821** Helped to found the Yorkshire Philosophical Society.
- 1825** Patented the Universal Railway, forerunner of the caterpillar tractor.
- 1826** Description of the Universal Railway (Figure 9) (Mechanics' Magazine).
- 1829** Prediction of absolute zero of temperature as -480°F (Tilloch's Philosophical Magazine).
- 1831** a) Paper on improvements to railway safety (Mechanics' Magazine). His earliest and rather impractical suggestions were occasioned by the death of William Huskisson in 1830 at the opening of the Manchester-Liverpool Railway, an event that he attended.
b) As a vice-president of the Yorkshire Philosophical Society, he helped to found the British Association for the Advancement of Science, and became life-member.
- 1832** Became a Member of Parliament for Scarborough. He withdrew his candidacy at the next election in 1835.
- 1837** Fourth paper on airships (Mechanics' Magazine). Again he proposes propeller propulsion.
- 1838** a) Presentation to the Institution of Civil Engineers on land drainage. He is elected Associate Member.
b) He founded the Polytechnic Institution, Regent Street, London. Later this became the Regent Street Polytechnic, which is now a part of the University of Westminster.
- 1840** Paper on safety in railway carriages (Mechanics' Magazine). Pointing out the inadequacy of existing buffers, he suggests the use of a compressed air spring buffer truck (Figure 10), seat belts and an automatic braking system (Figure 11).
- 1841** Further paper on railway safety (Mechanics' Magazine). He suggests the use of a block signalling system (Figure 12).
- 1842** Further paper on railway safety, occasioned by the rail disaster near Paris in which nearly 100 people were killed (Mechanics' Magazine).

- 1843** *Two further papers on Aerial Navigation (Mechanics' Magazine).*
- 1845** a) First paper describing an artificial hand (Figure 13) constructed to assist an amputee, his tenant's son, George Douseland (Mechanics' Magazine).
b) A further paper on railway buffer carriages (Mechanics' Magazine).
- 1846** Paper on experiments on shot (Mechanics' Magazine). He describes experiments with finned projectiles conducted at Scarborough in 1804-1805.
- 1847** a) Paper on railway buffers (Mechanics' Magazine).
b) Second paper on an artificial hand (Mechanics' Magazine).
- 1849** Third paper on an artificial hand (Mechanics' Magazine).
- 1852** *Paper on the Governable Parachute (Mechanics' Magazine).*
- 1853** *Paper on artificial flight (sent to the Bulletin of the Société Aérostatique et Météorologique de France).*
- 1856** Fourth paper on an artificial hand (Mechanics' Magazine).

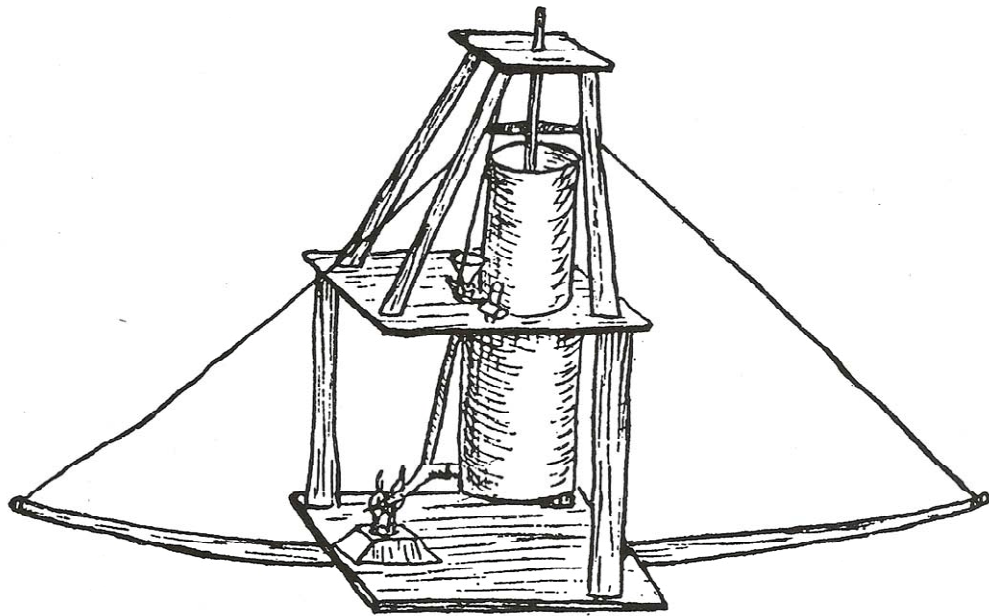

Figure 4 Gunpowder Engine, 1807.

Nicholson's Philos. Journal. Vol. XVIII. Pl. VIII. p. 261

Sir Geo. Cayley's Expansion Air Engine.

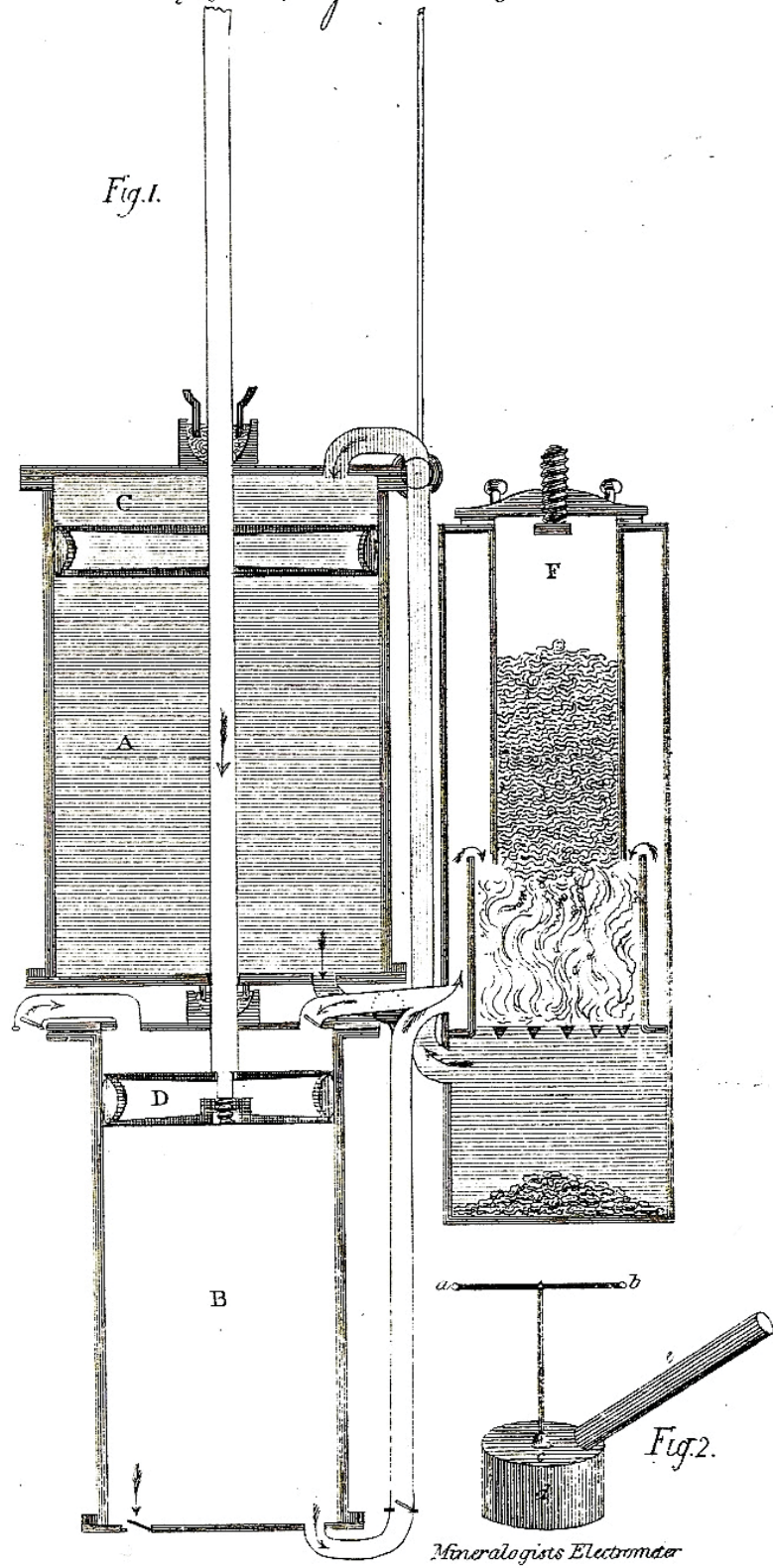

Figure 5 Hot Air Engine, 1807.

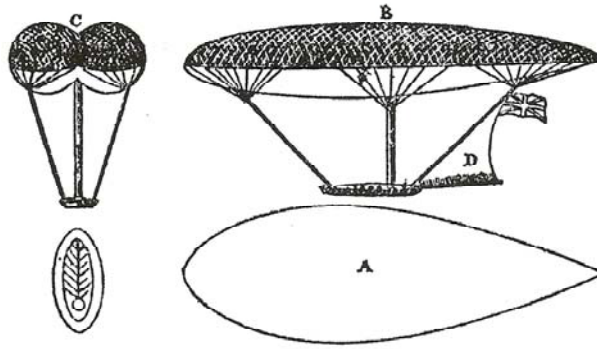

Figure 6 Airship, 1816

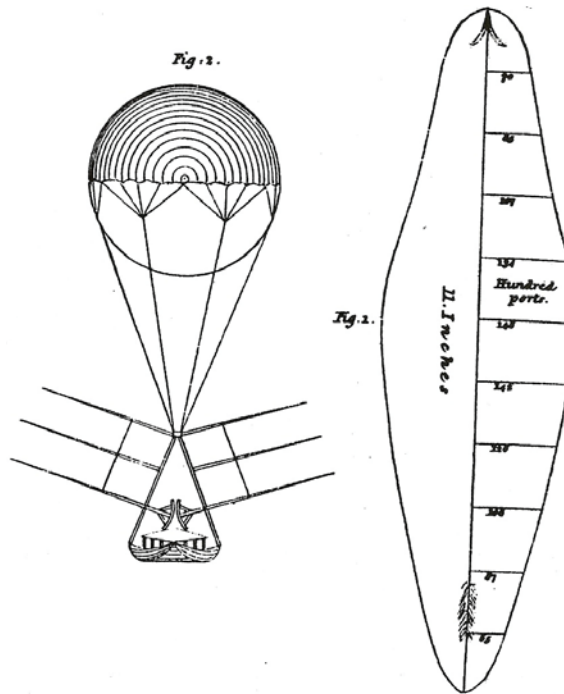

Figure 7 Airship, 1816.

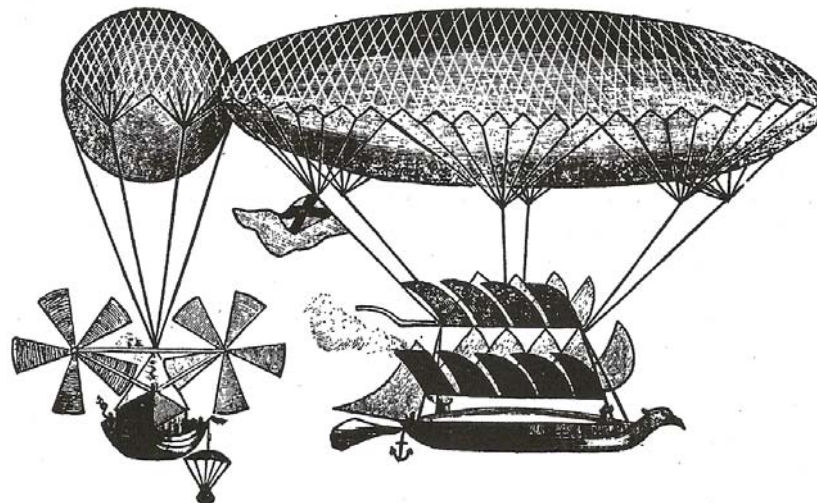

Figure 8 Airship, 1816.

Mechanics' Magazine,

MUSEUM, REGISTER, JOURNAL, AND GAZETTE.

No. 127.]

SATURDAY, JANUARY 28, 1826.

[Price 3d.

"That pains we take in books or arts which treat of things remote from the use of life, is but a busy idleness."—Fuller.

SIR GEORGE CAYLEY'S PATENT UNIVERSAL RAILWAY.

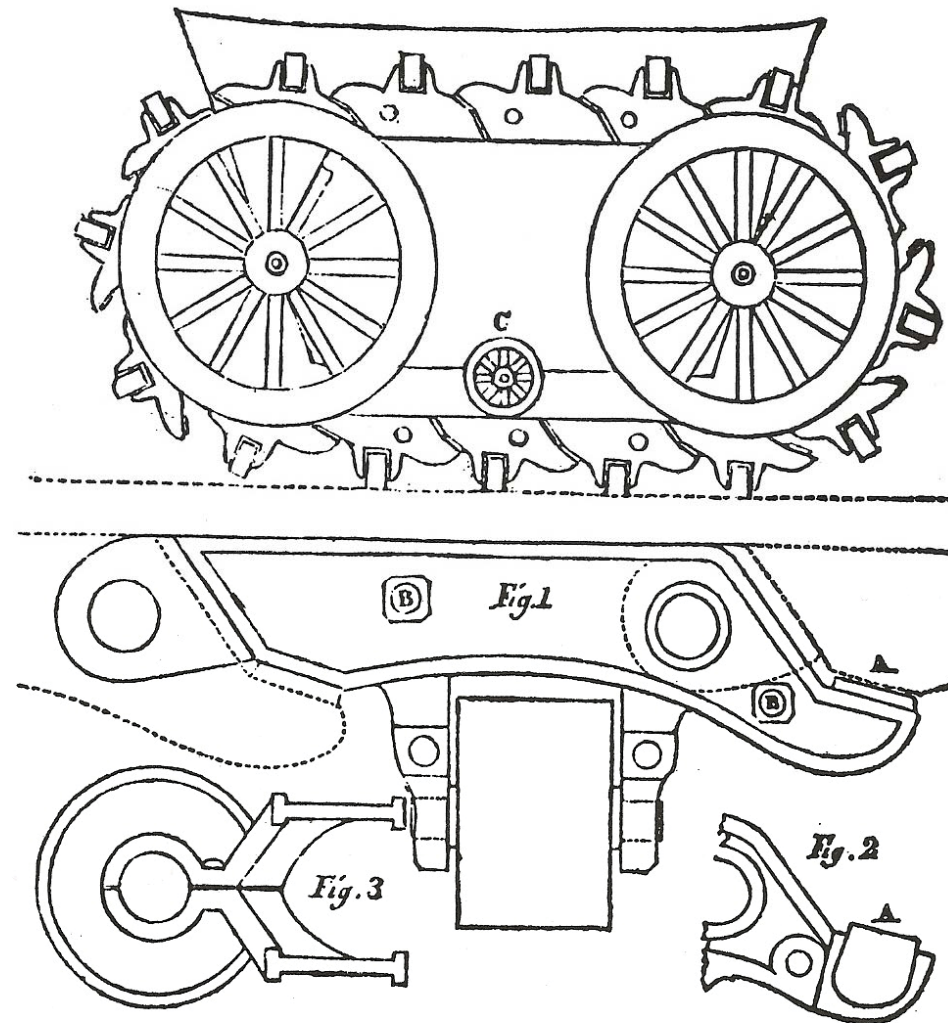

VOL. V.

9

Figure 9 Universal Railway, 1826.

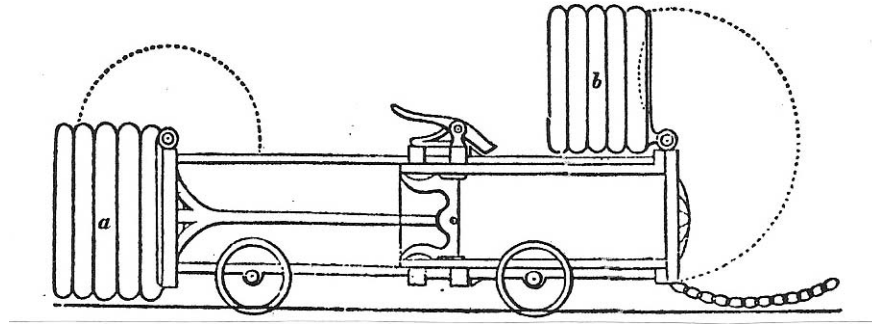

Figure 10 Railway Buffer Truck, 1840.

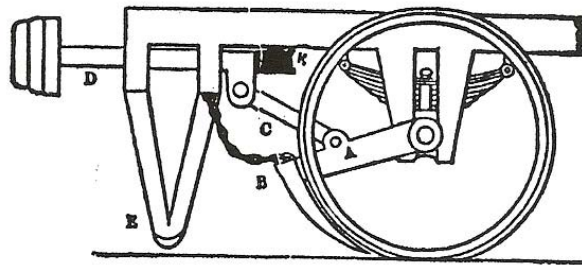

Figure 11 Railway Automatic Brake, 1840.

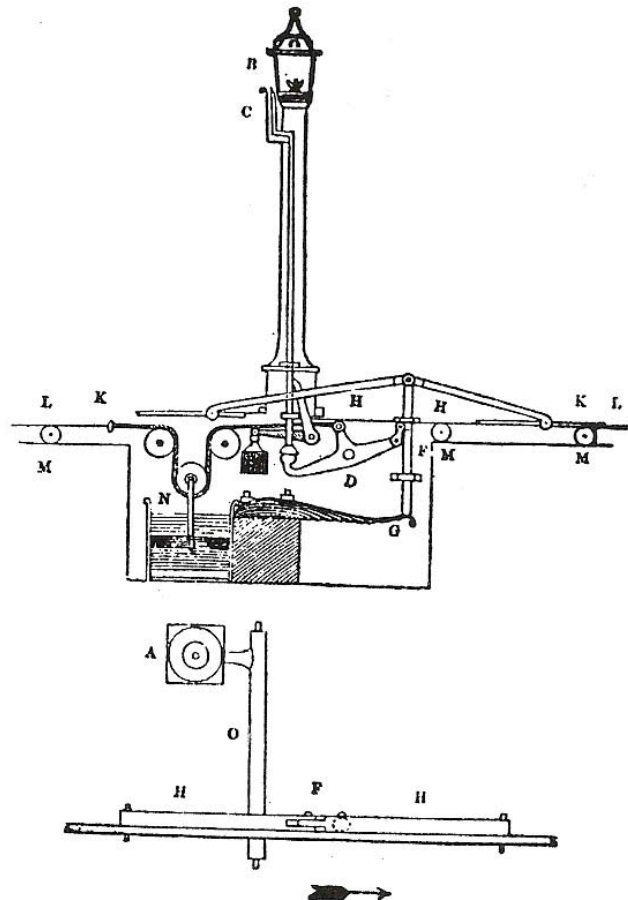

Figure 12 Railway Block Signalling System, 1841.

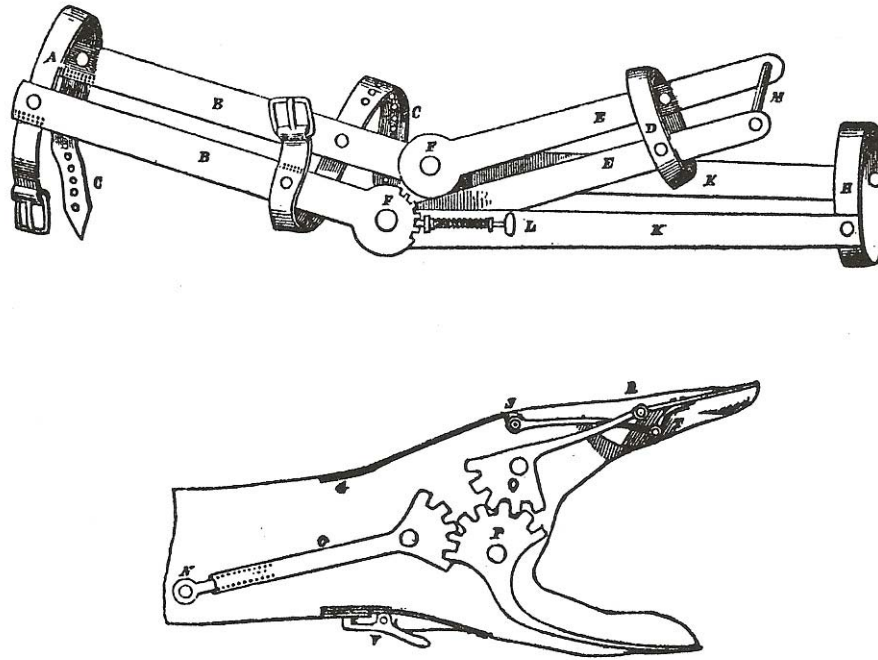

Figure 13 Artificial Hand, 1845.

In much of his constructional work Cayley was assisted by a local mechanic, Thomas Vick, of whom we can only wish that we knew more. It seems that they worked together largely in the hexagonal stone building (Figure 14) set into the wall surrounding Brompton Hall beside the Pickering road. The testing of the aeroplanes – “aerial crotchets” was Cayley’s wry term for them within the family⁽¹¹⁾ – was often conducted in Brompton Dale (Figure 15) on the opposite side of the Pickering road.



Figure 14 Hexagonal Workshop, Brompton Hall. (Author’s Collection)



Figure 15 Brompton Dale. (Author’s Collection)

Throughout his adult life Cayley retained an unshakeable belief that the fruits of his labours should be freely available to all mankind, particularly to those far less fortunate than himself. The above chronology attests, for example, to his continuing desire to assist

amputees. Indeed, his energetic promotion of humane social improvement provides striking examples of relevance to today's debates on society's direction. Not least of these is his concern for railway safety. In his 1842 paper on this subject, commenting on the then unrestrained profit motive of the private railway companies, he asserts that⁽¹⁰⁾

“If Government be not permitted to interfere with private property, for the purpose of protecting life, it is full time that this noble invention should be taken entirely into the hands of the Government, and thus ripened into safety.”

That his concern was well-founded is revealed in his 1847 paper, in which he condemns as “disgraceful and inhuman” the practice⁽¹⁰⁾

“...of placing second- or third-class carriages on the rear, to serve by being ‘smashed up’ with the bones of their passengers as buffers to those of the first-class...”

His remarks even now carry a certain resonance since once again, it seems, we are debating the issues of private or public responsibility for the provision of national amenities perhaps more important than our railway system.

Unusually for a member of the British aristocracy, he was initially supportive of the French Revolution yet later became sickened by its excessive violence. Thus with an optimism characteristic of that era, yet now tempered by hard-headed experience as relevant in today's turbulent world as it was then, he remarks in correspondence with a leading Whig politician at that time (Pritchard⁽⁹⁾):

“Human society improves in all arts, century by century; and the ultimate perfection of representative government cannot be thrust on a State unfit to receive it.”

Cayley's advocacy of education is clear from his involvement in the British Association and in the foundation of the Regent Street Polytechnic Institution. Writing to his long-time friend, Charles Babbage (1792-1871), on the establishment of this institution, his advice is that⁽¹⁰⁾

“We much want a good scientific board confined by no aristocracy of orthodox men who sit like an incubus on all rising talent which is not *of their own shop*. ... Freedom is the essence of improvement in science.”

With regard to the last sentence, in particular, recently Green⁽¹⁵⁾ has found it sadly necessary to express similar heart-felt feelings on behalf of today's “front line foot soldiers” concerning the present management and organisation of this country's aerospace research. Green's paper is one that all in aerospace should read.

As the above chronology also attests, Cayley presented much of his thinking in the open literature. Moreover, when fear of others patenting his ideas intruded, he took active steps to circumvent such moves. His entirely laudable attitude in this respect remains as worthy of emulation today as it did then.

Sir George Cayley died at Brompton on 15th December, 1857, twelve days before his eighty fourth birthday. The Parish Church of All Saints, Brompton, (Figure16) contains his remains⁽¹⁶⁾, he being the last of the Cayley line to be interred within the family vault which was closed in 1890. The Church itself was the venue, in 1802, for William Wordsworth's marriage to Mary Hutchinson of Gallows Hill Farm within the Parish. In 1895 a porch was added to the Church in memory of Sir George. Apart from the blue plaque at his supposed birthplace, the only other national memorial to this great man's efforts is the recently established small museum contained within his hexagonal workshop at Brompton Hall (Figure14).



Figure 16 Parish Church of All Saints, Brompton.
(Author's Collection)

3.0 EARLY EVOLUTION OF CAYLEY'S IDEAS ON THE AEROPLANE

Cayley's work on the aeroplane attempted to cover those four main subjects which were - and remain still - central to any reputable aeronautical curriculum: aerodynamics, flight dynamics including stability and control, structure, propulsion. Whilst it is tempting to deal with these separately, it is arguably more illuminating to describe his work chronologically. This approach, adopted here, is that used by Gibbs-Smith⁽²⁾. Episodic and lacking narrative flow as this may be, yet it has the advantage of tracing the evolution of Cayley's thinking. Since he was balked by the lack of an engine sufficiently light and powerful for his purposes, on the subject of propulsion he made little headway.

Thus his significant flying machines remained gliders, aeroplanes for which the propulsive force is provided solely by gravity. As to structure, here little sophistication had been achieved by his time so that his techniques, although sometimes remarkably advanced, otherwise erred on the side of the conservative, as we shall see. Thus it is in the two areas of aerodynamics and stability and control that his main achievements lie. And when Cayley came to aeronautics, it must be emphasised, it was precisely within these two areas that the main problems in the understanding of flight were to be found.

3.1 Cayley's Helicopter Model, c1796

Cayley tells us (see Ref. 2) that his first thoughts on mechanical flight occurred at Southgate in 1792. However, it was perhaps in the year 1796⁽²⁾ that he began active experiments, devising an adaptation of the helicopter toy demonstrated by Launoy and Bienvenu in Paris in 1784. Later illustrations of this French toy (for example, Figure17)

have prompted an interesting correspondence^(17, 18, 19) on how this was intended to work, the mechanism by which the propellers were set in contra-rotation being far from clear. However, in Cayley's adaptation (Figure 18, first shown in Cayley's paper of 1809⁽²⁾) propeller contra-rotation is ensured since the vertical shaft's base rests at a pivot hole in the whalebone bow, the bow itself being fixed to the lower cork whilst the upper cork is secured to the top of the shaft. The interesting point about this toy is that, whilst it served as Cayley's practical introduction to flight, he largely avoided use of the propeller throughout his career with the aeroplane.

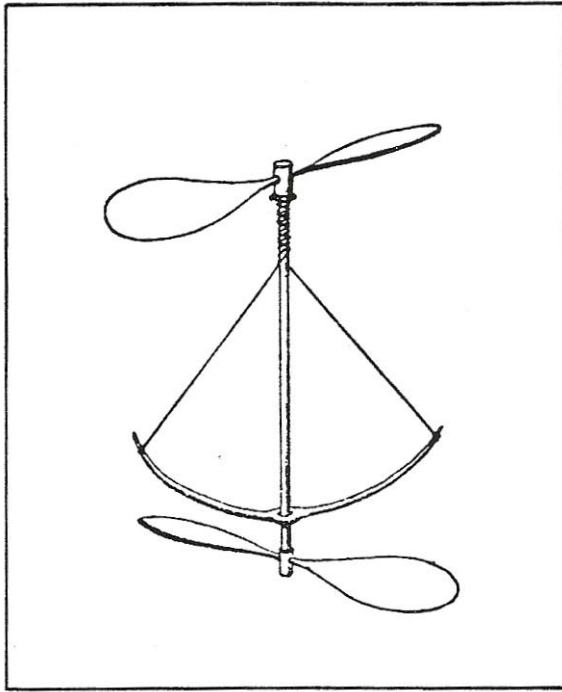

Figure 17 Helicopter Toy;
Launoy & Bienvenu, 1784.

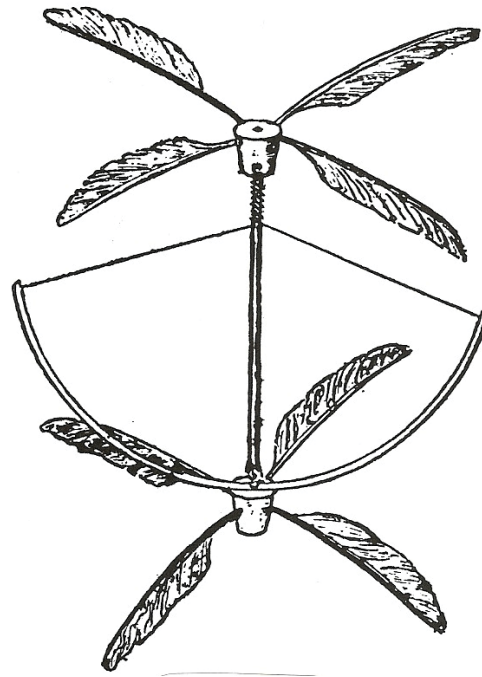

Figure 18 Cayley, Helicopter Toy, 1796.
(Cayley's paper of 1809⁽²⁾)

3.2 The Silver Disk, 1799

In 1799 Cayley took the seminal step which launched the aeroplane concept on its lengthy journey. He engraved his idea on one face (Figure 19a) of a small silver disk now at the Science Museum, London. The idea itself, like many others which have changed the world, is extremely simple; the propulsion and lifting systems are completely separated. Hitherto, flight had been attempted, unsuccessfully, by the use of flapping wings in a supposed emulation of bird flight. In Cayley's concept the lifting wing is a stationary low aspect ratio sail, its flexible surface cambered taut by the surrounding air pressure field. The separate propulsion system is a pilot-operated flapper arrangement owing much to the past. A cruciform rudder is provided, presumably with the intention that the machine be steered like a boat. The pilot is seated within a boat-like fuselage; since Cayley grew up near the sea there are a number of nautical allusions in his aeronautical work. His notebook⁽²⁾ at this time records what is probably the evolution of this concept, Cayley making estimates

of wing area and weight so as to arrive at the design, shown in Figure 20, which is very similar to that of the silver disk engraving.



Figure 19 Cayley, Silver Disk, 1799.

(© Science Museum / Science & Society Picture Library - All rights reserved.)

Figures 19a (left) and 19b (right)

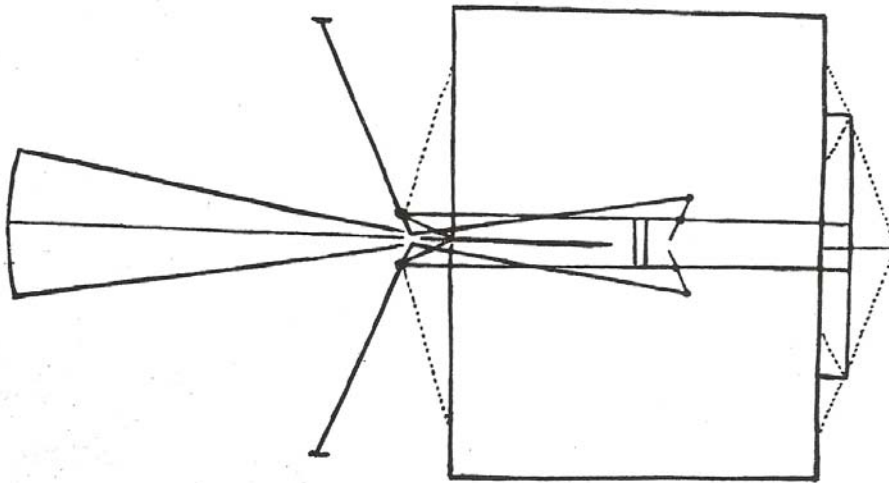

Figure 20 Cayley, Aeroplane Design, c1799.

The reverse of the disk (Figure 19b) shows Cayley thinking scientifically about the problem of flight. The force of air resistance is shown acting perpendicularly to a flat surface, a somewhat oversimplifying assumption as to force direction which was to remain with him throughout his career. This assumption concerning force direction may have arisen from Cayley's belief either that the force would be due entirely to air pressure or that it would follow the dictates of the Newtonian 'rare medium' concept. The latter we will come to presently. However, the crucial step is Cayley's employment of the simple device of the triangle of forces, by which he resolves the air resistance into its lift and drag components.

The disk's history, though distinctly limited, is itself interesting. As related to the authors of Ref. 11, in 1925 an elderly lady brought it to the Scarborough premises of Richard Smith & Sons, Watchmakers and Silversmiths, together with a collection of silver oddments and jewellery. Without giving her name, she indicated that her mother had been a Cayley of Brompton. Mr T A Smith, who purchased the lady's collection, later realised the disk's significance and presented it to the Science Museum.

3.3 Early Thoughts on Incidence Effects, c1801

In an early notebook entry, which Gibbs-Smith⁽²⁾ places around 1801 (the full text can be found in Ref. 4), Cayley again employs the triangle of forces in an attempt to describe the flight of birds. He deals not only with gliding flight but also with the bird's wing movement required to obtain propulsive thrust. Cayley's writing style here is of interest since it is reminiscent of Newton in the 'Principia'⁽²⁰⁾, a work with which he must, at least in part, have been familiar. The first passage - as reproduced, a huge sentence twelve lines long⁽⁴⁾ - has the style of a formal Newtonian Proposition [my emphasis in italics]:

"If birds when in that act of flying ..., I say it will be necessary for the wing .."

What follows is an attempt at formal proof, correct in so far as it deals with gliding flight. In the end, of course, solid results depend upon the variation of lift with wing incidence. Here Cayley⁽⁴⁾ notes that

"Theory would estimate the increase of resistance...as the square of the sine of the angle of incidence, but experiment determines it to be in a mean between the direct ratio of the sines and that of their squares."

Precisely which experiments he refers to here is unclear. The only results for plates available at that time had been provided by the whirling arm experiments of Vince⁽²¹⁾ in 1798. Although of doubtful accuracy (see Ref. 22), they show the behaviour noted by Cayley. Other contenders, also providing agreement with Cayley's statement, are the results from whirling arm tests in both air and water of Borda^(23, 24) from 1763 and 1767 and the towing tests in water reported by d'Alembert, Condorcet and Bossut⁽²⁵⁾ in 1777. Here it should be noted that in all of these cases plates were not tested, Borda using wedges of various angles whereas d'Alembert et al towed barge models having a variety of bow angles. However, a prevailing view at that time was that the flat faces of bodies should generate resistance as if acting as independent flat plates. This belief had gained support from Newton's⁽²⁰⁾ 'rare medium' concept. In this a fluid is assumed to be composed of discrete particles streaming in parallel straight lines until they collide with the body surface so as to generate resistance there by direct momentum change (see Ref. 22).

Although Newton had doubted the general validity of this concept, its later application had led to the sine squared incidence result for plates mentioned above by Cayley. Indeed, in a later note from this same period, around 1801, Cayley⁽⁴⁾ quickly runs through its derivation. However, in a following notebook passage, Cayley⁽⁴⁾, in again discussing bird flight, here appeals to "the French experiment on angular resistance". On the authority of the French aviation historian, Charles Dollfus, Hodgson⁽⁴⁾ believes this to be a reference to d'Alembert et al "in 1763", a reference thus far not traced. The date, 1763, suggests a possible confusion with Borda's⁽²³⁾ paper of that year, yet Borda there reports only on

wedges of large angle, not the 6° incidence case mentioned by Cayley. The most likely candidate is then the paper by d'Alembert et al⁽²⁵⁾ of 1777. Commenting on the results presented there, Euler⁽²⁶⁾ believes them to be applicable to plates in the small incidence range, for which case he then argues that a plate's resistance is more nearly proportional to the sine of its incidence angle. This assertion, correct but fortuitous since wedge shapes rather than plates had been tested, was to be mirrored in Cayley's later statements concerning wings. Clearly, however, Cayley was now finding himself in the position of having to address this crucial question of lift dependence on incidence angle.

3.4 The Whirling Arm Experiments, 1804

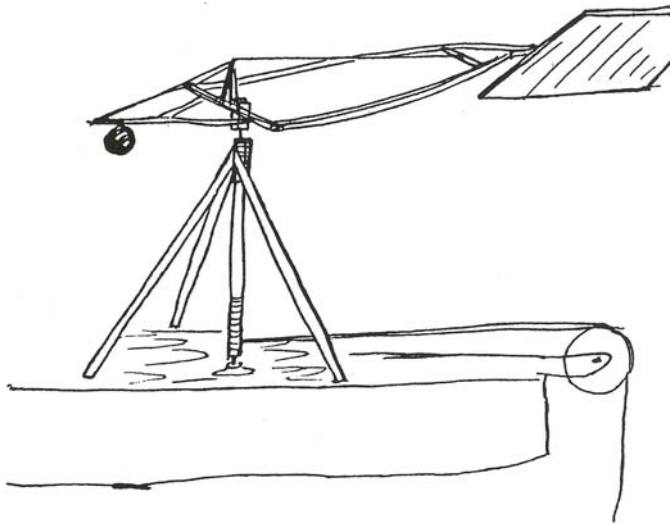

Figure 21 Cayley, Whirling Arm, 1804.

Incidence dependence apart, theoretical results obtained thus far⁽²⁰⁾ had indicated a direct proportionality between resistance and fluid density, an area characteristic of the body and the square of the flow speed. Experiments^(20, 21, 23, 24, 25, 27) had largely supported these conclusions and, indeed, Cayley took them almost as axiomatic in his own experiments of 1804 to determine the effect of incidence. Details of these tests and their results are given in his notebook entry^(2, 4) for December of that year. The

apparatus itself (Figure 21) was an adaptation of the whirling arm first demonstrated by Robins⁽²⁷⁾ in 1746, his paper on the subject being read before the Royal Society in the following year. To this Cayley added a horizontal hinge at the arm's junction with the vertical drive shaft so that the arm acted as a lever. At rest the arm and test plate were counterpoised by the weight shown (Figure 21) on the arm's leftward extension, the apparatus being sufficiently sensitive, as Cayley^(2, 4) puts it,

“...that the 1/16 of an oz. turned it easily from an horizontal position.”

The test body was a paper plate 1 ft square (0.093 m^2). The arm and plate were driven in rotation by the cord and pulley system shown. The driving weight descended the stairwell of Brompton Hall (Figure 22), a height sufficient for the plate to travel a circular distance of about 600 ft (183 m). Because of this circular motion, Cayley realised that the plate's centre of pressure location must lie outboard of the plate's mid-span position. This location he^(2, 4)

“...computed by squaring the velocities that each vertical strip of the square one foot wide gave, and finding the medium point of resistance.”

In other words, he assumed the validity of the velocity-squared resistance rule, divided his plate into chordwise strips and then estimated the centre of pressure location by numerical

integration. Since he went to this trouble and writes of “the weights lifted upon the path of the plane”, the more obvious assumption is that he measured the lift force by placing weights at the plane’s computed centre of pressure so as to keep the arm rotating in a horizontal plane. Alternatively, he could have changed the value of the counterpoise weight so as to achieve horizontal rotation. Again, the computed centre of pressure location would have been required, to be used in conjunction with the method of moments so as to calculate the lift force. Two arm rotation speeds were used and the plate incidence was varied in 3° steps from an initial incidence of 3° up to 18° (inadvertently, one result was obtained at 20° incidence).

The results have been reduced to the modern notation of lift coefficient, C_L , by Yates⁽²⁸⁾.



Figure 22 Stairwell, Brompton Hall.
(Author’s Collection)

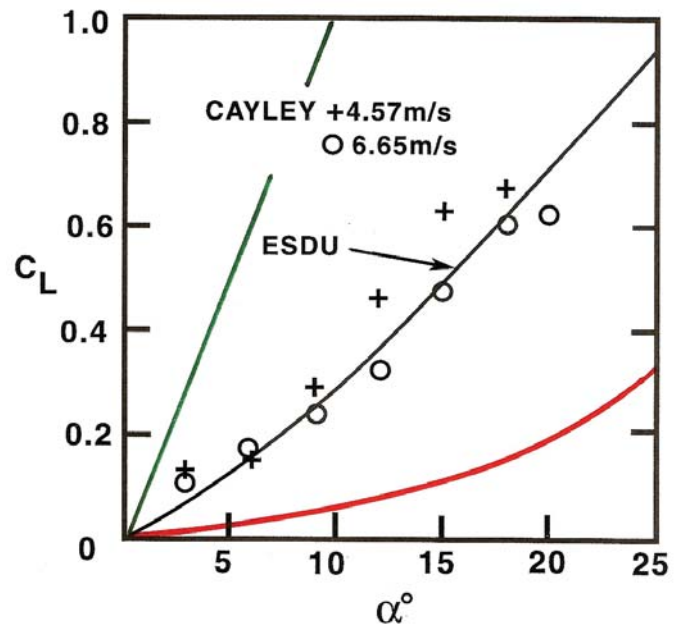

Figure 23 Cayley, Whirling Arm Results, $C_L \sim \alpha$
(Yates⁽²⁸⁾ and modern data⁽²⁹⁾).

They are shown in Figure 23 not only to exhibit a reasonable collapse according to the velocity-squared rule but also to compare favourably with modern experimental data provided by the Engineering Science Data Unit (ESDU)⁽²⁹⁾. Whilst indicating a variation near to a sine relationship at small incidences, the data at higher angles hint at the upward drift to a sine squared behaviour characteristic of plates and wings of very low aspect ratio. Also shown in Figure 23 is the green curve representing the results of circulation theory ($C_L = 2 \pi \sin \alpha$) provided by Kutta⁽³⁰⁾ and Zhukovskii⁽³¹⁾ in 1910 for a wing of infinite aspect ratio, a curve to which modern high aspect ratio wings tend. The red curve of Figure 23 represents the Newtonian sine squared incidence relation ($C_L = 2 \sin^2 \alpha \cos \alpha$), the definitive derivation having first been provided by Euler⁽³²⁾. Thus whilst Cayley’s plate results fall far short of what is now expected of a modern high aspect ratio wing, they are much superior to the predictions of Newtonian theory; the latter observation no doubt confirmed Cayley’s earlier suspicions concerning that theory.

Although Cayley could also have measured the plate's drag force variation with incidence in the Robins⁽²⁷⁾ manner, he appears not to have done so and his notebook data are insufficient for such results to be obtained. However, because of his assumption that resistance acts in a direction normal to the surface, when required subsequently he adopted the practice of estimating drag from lift results by the use of simple geometry. Whilst this procedure was adequate for most cases, it failed, of course, at zero incidence. In his 1804 whirling arm experiments he also tested the plate at 90° incidence and at two rotation speeds. Since he comments that he⁽⁴⁾

“...had not a barometer to note the weight of the atmosphere at the time,”

as with most data from these early days, the process of obtaining a C_D value from his results is a little speculative. However, calculation suggests a value around 1.5, a marked improvement on that of about 1.9 which follows from the results quoted by Smeaton⁽³³⁾ and provided by his friend, a certain Mr Rouse of Harborough. In contrast, the presently accepted value for square plates⁽²⁹⁾ is the even lower value of 1.14.

3.5 The First Glider, 1804

Carrying the same date as the description of the whirling arm tests, December 1st 1804, Cayley's notebook immediately follows that description with this rather surprising comment^(2, 4):

“I have my doubts however whether this mode of circular motion does create as much resistance as when the plane moves on in a right line keeping parallel to itself.”

Apparently motivated by this doubt, what follows is Cayley's description of his tests with a simple kite modified so as to perform as a glider, the first aeroplane to fly. His sketch of it is shown in Figure 24 and is now incorporated in the Society's Gold Medal beneath a portrait in relief of Cayley himself. The kite forming the wing had an area of 154 square inches (0.1 m²) and was fixed at 6° to the rod fuselage. There is notebook evidence from as

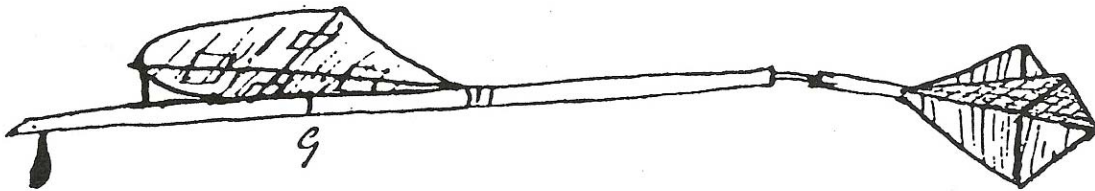

Figure 24 Cayley, Glider, 1804.

early as 1801 that he took such an angle to be typical of a crow's wing in flight. In contrast to that of the crow, the wing's aspect ratio was markedly low, probably less than unity. Cayley's choice of centre of gravity location is revealing^(2, 4) [my explanatory additions in brackets]:

“The centre of gravity was varied by sticking a weight with a sharp point into the stick. The whole weight was 3.82 oz., and when the centre of gravity, G,

was under such part of the kite as left 75 [square] inches on the anterior part and 79 [square inches] behind it, and with the tail at an angle of 11.5° , then if a velocity of 15 feet per second was given to it in an horizontal direction, it would skim for 20 to 30 yards supporting its own weight, and if pointed downward in an angle of 18° , it would proceed uniformly in a right line for ever with a velocity of 15 feet per second.”

In 1983 Hugh Jackson, an Aeronautical Engineering student at Manchester University, built a replica of this glider as part of his Final Year Project⁽³⁴⁾. When flown in still air conditions in the Department’s Barton Laboratory, the replica descended at the angle and speed stated by Cayley.

The above quotation from Cayley’s notebook can be read as if he had deliberately chosen to locate the centre of gravity so as to lie close to the wing’s mid-area in the belief that the latter location would be the centre of pressure. If so, he may have been guided by a belief that the wing was subjected either to a uniform pressure distribution or to the dictates of the Newtonian ‘rare medium’ concept. Experience had then taught him that the tailplane should be set at its high positive incidence in order to achieve successful glides. In this notebook passage there is no mention of trim considerations (zero overall moment about the centre of gravity), from which he could have deduced that, given the tail’s incidence and lift, the wing’s centre of pressure must have been forward of the centre of gravity at its mid-area location. Of course, due to the wing’s likely substantial downwash, the tail’s nose-down moment would not have been as large as its high positive setting angle of 11.5° might suggest.

Cayley’s near-triangular wing of low aspect ratio - a form of reversed slender delta - is something of an aerodynamicist’s nightmare. One envisages the leading edge inducing gross upper surface separation like that on a flat plate. However, the sharply angled long trailing edges might be expected to produce along their lengths a system of rolled up vortices which could, on a wing of such small span, cause upper surface rearward re-attachment along the wing’s centreline. Whilst the upper surface’s fairly low suction would therefore be restricted to the forward part of the wing, its chordwise extent perhaps contracting with increasing incidence, the undersurface stagnation point can be expected to move rearward with increasing incidence, although probably not as far as that on a square plate. Consequently, it is difficult to predict the centre of pressure’s movement with change of incidence.

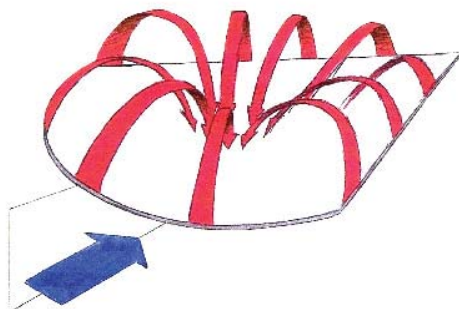

Figure 25 Flow field about a wind tunnel model of the 1804 Cayley wing (Potter, reference 35).

In an attempt to settle this and a number of other points related to this first wing to fly, in 2001 Graham Potter, also an Aeronautical Engineering student at Manchester University, performed wind tunnel experiments on a model of the wing⁽³⁵⁾. Using smoke and surface flow visualisation methods, he was able to construct a picture of the wing’s upper surface flow field, shown in Figure 25, which confirms the presence and suspected effect of the angled trailing edge vortices. He

found, moreover, the presence of a secondary vortex aligned a little aft of the leading edge, this caused by the leading edge separated layer's forward motion after its re-attachment. Lift and drag force measurements were also made, the values of C_L being found to lie close to those for the square plate shown in Figure 23 and reaching a value of 1.1 at 30° incidence. Potter⁽³⁵⁾ also provided calculations of C_L and C_D based on lifting line and cross flow theories, the latter being found to agree closely with his measurements. Whilst gratifying, this is to be expected since cross flow theory is valid for wings of low aspect ratio, such as this, whilst lifting line theory applies strictly to wings of higher aspect ratio.

However, the crucial part of Potter's investigation is his measurement of the centre of pressure position. This is found to lie around $0.15c$ (c being the wing's maximum chord) at low incidence and then to move steadily rearward to about $0.3c$ at an incidence of 30° . Two important points follow from this. The first is that, within this incidence range, the centre of pressure is forward of the wing's mid-area at about $0.4c$, the centre of gravity location chosen by Cayley for his glider, so that a nose-down moment from the tail would indeed be required for trim. The second point is that, because of this rearward movement of the centre of pressure with incidence increase, this type of wing is statically stable. Cayley's inclusion of a tailplane would merely enhance the static stability inherent to the wing itself. Therefore a tailplane is needed merely for re-trimming purposes. However, this may not be the case for some of Cayley's subsequent designs, to be discussed later, in which he used higher aspect ratio wings of rather more modern shape for which a tailplane would be necessary for stability.

The glider's downward path of 18° to the horizontal reveals a modest L/D ratio of 3 (in still air conditions, $L/D = 1/\tan 18^\circ$). As Yates⁽²⁸⁾ calculates, the glider probably set itself in trim at a wing incidence of 20° to that path – not the 6° wing setting angle assumed by Cayley in his notebook at this time – and with a C_L value of 0.7, the corresponding C_D value being therefore about 0.23. Thus Cayley's glider would have flown with its wing slightly uptilted from the horizontal, a feature noted in Jackson's test⁽³⁴⁾ of his replica. Cayley's assumption of a wing incidence of 6° reveals his misunderstanding of true incidence at this time. Indeed, misunderstanding of incidence continued in the work of later flight pioneers, prompting Wilbur Wright in 1901 to write a brief paper⁽³⁶⁾ elucidating the matter. Nonetheless, Cayley's mistake caused him to suspect that the apparently large discrepancy between his glider's lift and his whirling arm results might be due, not to the rotation of his test plate (his original source of disquiet), but to the glider's flexible wing surface becoming cambered. The latter effect he already suspected as enhancing the lift of birds and indeed anticipated further beneficial effects from the use of higher aspect ratio wings.

3.6 Further Thoughts on Camber, Aspect Ratio and Incidence, 1808

The subjects of camber and high aspect ratio are returned to in a notebook entry for February, 1808. Having shot and examined a heron, Cayley^(2, 4) is

“... apt to think that the more concave the wing to a certain extent the more it gives support, and that for slow flights a long thin wing is necessary ...”

And, in describing an ornithopter design in the following month, now no doubt emboldened by his own whirling arm experiments, Cayley^(2, 4) asserts that

“...the resistance...varies nearly as the sine of the angle of incidence...”

The aeronautical world had to await rigorous analytical support for this in the circulation theory of lift provided by Kutta⁽³⁰⁾ and Zhukovskii⁽³¹⁾ in 1910, although Lanchester⁽³⁷⁾ had accepted it as correct for his rudimentary wing analyses from about 1894 onwards (see Ref. 38).

3.7 The Tension Wheel, 1808

In the same month, March 1808, the notebook records his invention of the tension wheel (Figure 26) in his search for “the lightest possible wheel for aerial navigation cars”. His idea is^(2, 4)

“.. to do away wooden spokes altogether, and refer the whole firmness of the wheel to the strength of the rim only, by the intervention of tight strong cordage..”

In other words, the hub is held suspended at any instant by those cords in tension which are

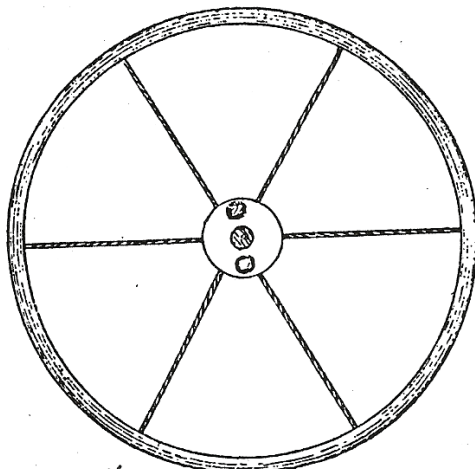

March 19th 1808 Gf.

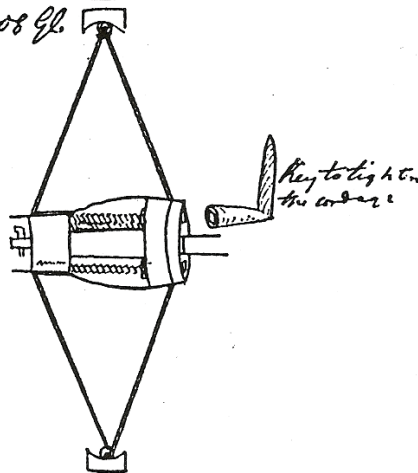

*see remarks
page 138*

attached to the upper rim. The modern bicycle wheel replaces the cordage by thin metal extrusions. Cayley's design also incorporates a key-operated device (shown in the lower drawing of Figure 26) to tighten the cordage correctly. Cayley did not patent his invention and, suspecting the leak of his idea, was somewhat shocked to learn that Theodor Jones had applied to patent a similar idea for carriage wheels in 1826.

3.8 The Glider of 1808

In April of 1808 Cayley applied his thinking on camber and high aspect ratio to the glider shown in Figure 27. His notebook^(2, 4) records that this was

“...a large kite formed of an hexagon with wings extended from it, all so constructed as to present a hollow curve to the current...”

Later in this same note he again remarks on this use of camber^(2, 4):

Figure 26 Cayley, Tension Wheel, 1808.

“It should be observed that these wings were considerably hollow and much wood that made direct resistance, and that they were not in one plane but inclined upwards.”

Evidently, then, Cayley was now also experimenting with dihedral, although he gives neither indication of his reasoning for it at this stage nor the angle used. The wing planform, of course, is of major interest. The leading edges of the hexagonal centre section no doubt would act as modern leading edge extensions and, like the slender delta, generate mid-semi-span upper surface vortices which would enhance lift at higher incidences. Although no span dimensions are given, wing surface areas only being recorded, the wings themselves appear to have been of reasonably high aspect ratio. Remarkably, this feature was not to be repeated in any of Cayley’s other designs. However, the interesting point is that here, for the first time, Cayley attempts to determine trim conditions for an aeroplane. He writes that^(2, 4)

“...I found that.....it required the centre of gravity to be suspended so as to leave the anterior and posterior portions of the surface in the ratio of 3 to 7.”

This ratio is recorded in his sketch (Figure 27). However, the tailplane is set at a positive incidence, as had been used on the 1804 glider. In the next sentence, he attempts to judge the effect of its nose-down moment so as to re-estimate the wing’s centre of pressure location^(2, 4):

“But as this included the tail operating with a double leverage behind, I think such hollow surfaces relieve about an equal pressure on each part, when they are divided in the ratio of 5 to 12, 5 being the anterior portion.”

Again he is in no position to appreciate the effect of wing downwash on tailplane lift.

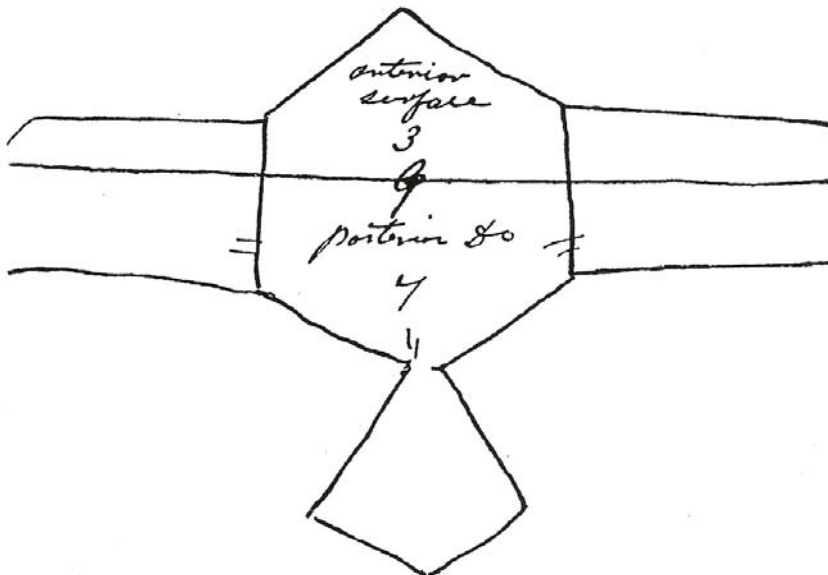

Figure 27 Cayley, Glider, 1808.

Consequently, with this argument he places the wing’s centre of pressure perhaps a little too far forward. However, in both estimations he has nevertheless arrived at the important point that a wing’s lift can lie forward of the wing’s mid-area and, indeed, here a little aft of the quarter chord point. This strikes him as remarkable^(2, 4) [my explanatory addition in brackets]:

“It is really

surprising to find so great a difference, and it obliges the centre of gravity of flying machines to be much forwarder of the centre of bulk [centroid of area] than could be supposed a priori.”

Later in the same note, however, he seems to doubt this conclusion. He notes that the wing was placed significantly above the centre of gravity so that its drag, together with that of the wooden support structure, would cause a nose-up moment ^(2, 4):

“Hence the centre of support was much above the centre of gravity, and as the weight was the moving cause, being projected horizontally the retarding power of the plane arising from its degree of obliquity to the horizontal path, and also the direct resistance of the wood work, operated to depress the hinder part of the balance. This will most probably account for the necessity of the centre of gravity being obliged to be removed forward.”

In other words, he is now beginning to think that the wing’s centre of pressure might not be quite so far forward as he had earlier supposed. Indeed, in the note’s last sentence he appears to be back to square one ^(2, 4):

“I tried a small square sail in one plane, with the weight nearly in the same, and I could not perceive that the centre of resistance differed from the centre of bulk.”

Significantly, there is no indication here that Cayley investigated the *movement* of the centre of pressure with incidence change, contrary to Gibbs-Smith’s ⁽⁵⁾ claim.

3.9 Structural Ideas, 1808

A notebook entry for May, 1808, records his thinking on the provision of light yet rigid structures for flight. He refers to ^(2, 4)

“...the lightest and strongest form of a middle pole and seat for aerial navigation, the pole to be made in halves, tapering each way from the cross-pieces and hollowed to form a tube. Bamboo canes would be most excellent rods for aerial navigation purposes.”

The hollow quill of a bird’s feather, of course, provides another case in point. However, Cayley’s perhaps instinctive idea here seems to be one of the earliest to employ what the emerging structural theory was beginning to teach. Nowadays we all accept the advantages, in terms of lightness and rigidity, of the use of section shapes having high second moments of area in order to resist bending moments and torque. The theoretical reasoning underpinning such principles had begun to emerge during the eighteenth century in the work of Jacob Bernoulli, Euler, and others (see, for example, Refs. 39 and 40) but it is doubtful either that much of this had been recognised by the engineering practitioners of those days or that Cayley himself would have been aware of it.

Examples of contemporary structural techniques can be found in the iron-framed cotton mills erected in the Ancoats district of Manchester in the period 1790-1820. These often used T section beams, the horizontal upper flange plate forming the T being added perhaps more to support the brick and woodwork above than in a deliberate attempt to enhance the second moment of area. The addition of a further bottom flange, so as to form an even

stiffer I section, seems not to have occurred to the builders. Thus Cayley's ideas, particularly that regarding the use of *tapered* hollow sections, emerge as being remarkably advanced for their time. Later, as we shall see, he was to add his thoughts on diagonal wire bracing so as to enhance further a structure's stiffness. Little advance was made in this area until Octave Chanute introduced the Pratt truss cross-bracing system to aeronautics in the Chanute-Herring glider of 1896 (see, for example, Ref. 41).

3.10 The Solid of Least Resistance, 1809

Cayley, the countryman, delighted in recording his observations of nature. His deductions were frequently acute, not least in his dealings with the shape of a trout. His note, dated June 1809, records this as "a well fed fish". Measuring its girth distribution from nose to tail, he writes that ^(2, 4) [my explanatory addition in brackets]

"...the girths are divided by three [as an adequate approximation to π] and reduced to a mean diameter so as to give a spindle the same girth at the respective places that the trout had. Why should not a boat be constructed to resemble one half of such a spindle by a section thro' the axis? We would then be deriving our boat from a better architect than man, and should probably have the real solid of least resistance."

Cayley's sketch of the cross section of the resulting axially symmetric body is shown in Figure 28. Von Kármán ⁽¹⁴⁾ has noted how very close this cross section is to that of a modern low drag NACA 63A016 aerofoil shape, the latter albeit a Cartesian two dimensional section. Despite the long history of boat and ship-building, rarely does it appear that constructors questioned the use of the relatively streamlined shapes they employed. The first investigator in more modern times to suggest such shapes, specifically for resistance reduction on barges and bridge piers, appears to be Du Buat ⁽⁴²⁾ in 1786. The correct reasoning behind streamlining, given in terms of the suppression of separation, did not emerge until Prandtl ⁽⁴³⁾ revealed the concept of the thin boundary layer in 1904. Lanchester ⁽³⁷⁾ also grasped a rudimentary understanding of this concept at about this time.

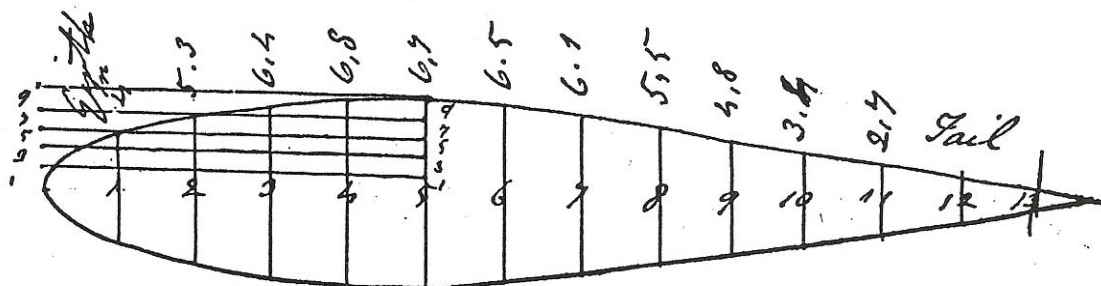

Figure 28 Cayley, Solid of Least Resistance, 1809.

4.0 THE TRIPLE PAPER ON AERIAL NAVIGATION, 1809-1810

Due to a misunderstanding, for which the world must be forever grateful, Cayley was moved to publish his findings in a three-part paper which ushers in the science of

aeronautics. In 1809 reports had reached Britain that, earlier that year, Jacob Degen (1761-1848) had flown successfully in Vienna. Later it emerged that such reports had neglected to mention the hydrogen balloon which had carried aloft Degen's man-powered flap-valve machine.

In the paper's first part Cayley summarises his intentions as follows⁽⁴⁴⁾:

“I am induced to request your publication of this essay, because I conceive, that, in stating the fundamental principles of this art, together with a considerable number of facts and practical observations, that have arisen in the course of much attention to this subject, I may be expediting the attainment of an object, that will in time be found of great importance to mankind; so much so, that a new æra in society will commence, from the moment that aerial navigation is familiarly realized.”

He then takes Degen's ascent as confirmation of his assertion that⁽⁴⁴⁾

“There is no proof that, weight for weight, a man is comparatively weaker than a bird; it is therefore probable, if he can be made to exert his whole strength advantageously upon a light surface similarly proportioned to his weight as that of the wing of the bird, that he would fly like the bird...”

Whilst such a “curious and interesting circumstance” may be the first means by which man-carrying flight is to be achieved, this, he feels, will be of little use. However⁽⁴⁴⁾,

“I feel perfectly confident ... that this noble art will soon be brought to man's general convenience, and that we shall be able to transport ourselves and families, and their goods and chattels, more securely by air than by water, and with a velocity of from 20 to 100 miles per hour.”

Step by step, Cayley then addresses those four crucial areas – propulsion, aerodynamics, stability and control, structure – necessary to the successful achievement of powered flight.

4.1 Propulsion

In the first part of the paper, Cayley summarises the current situation regarding engines. For the steam engines then projected (expansion-operated, with light-weight tubular boilers), he can foresee no lower figure than about 163 lb per horsepower (0.099 kg/W). Stokes⁽¹⁷⁾ has provided data (Figure 29) corroborating this assessment which show further that engine mass per unit power had to reduce by more than a factor of ten before practical powered flight became possible. However, Cayley adds that⁽⁴⁴⁾

“...lightness is of so much value in this instance, that it is proper to notice the probability that exists of using the expansion of air by the sudden combustion of inflammable powders or fluids with great advantage.”

By this time Cayley was already the inventor and leading authority on the heated air engine (see Figure 5). However, there is no indication that he here foresees the advantages of an *internal* combustion engine. Nonetheless, he then gives a brief indication of what had been done, what might be achieved, using spirit of tar or gas as the combustible fluids. As to the

manner by which power is to be translated into forward thrust, the second and third parts of the paper devote much space, fruitlessly as it turned out for future developments, to descriptions of the various flapper systems he favours.

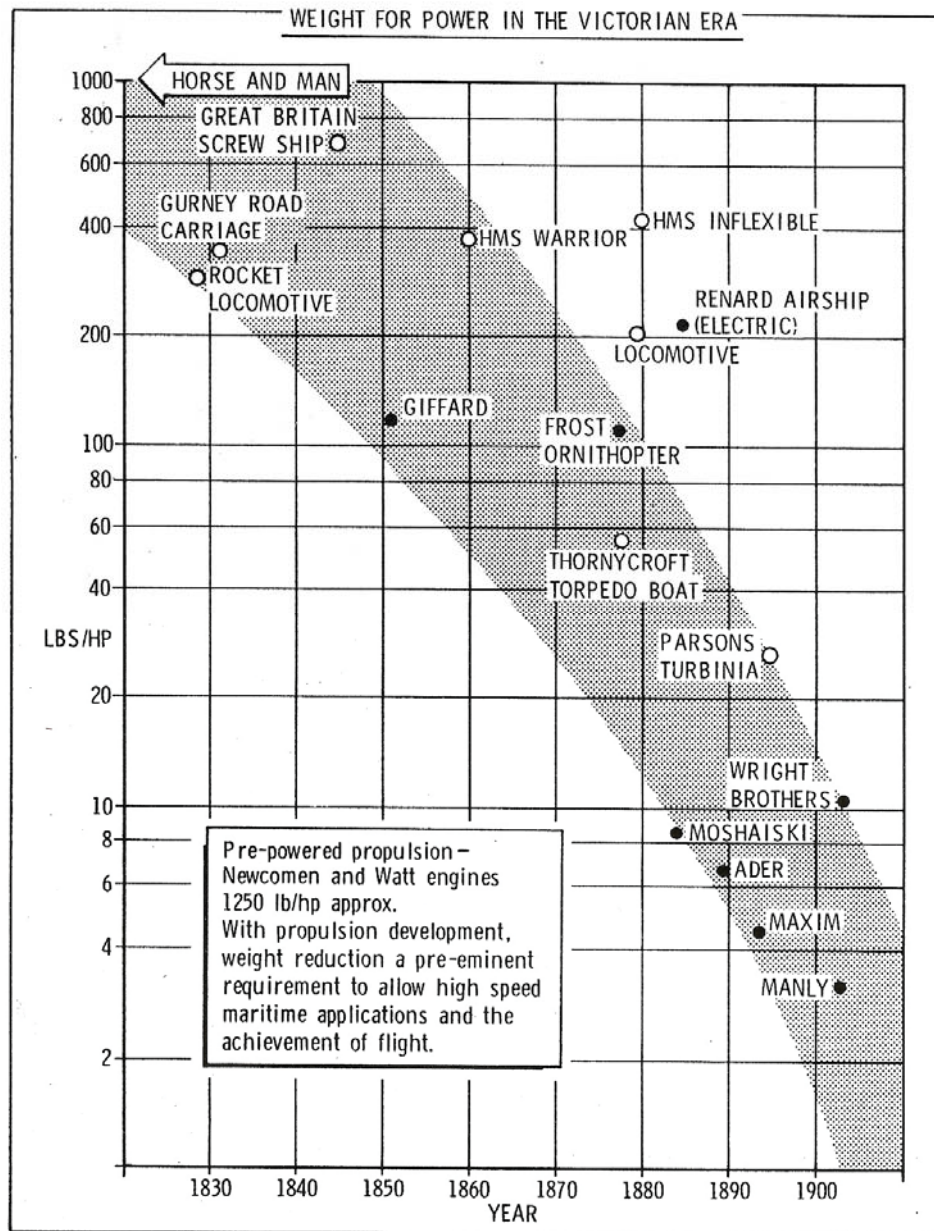

Figure 29 Power Improvement with Time (from Stokes⁽¹⁷⁾).

4.2 Aerodynamics

In the first part of the paper, Cayley uses the example of bird-flight to explain the action of the lifting wing. This is a distillation of his earlier notebook entries already described. Again, the wing's total resistance is taken to act perpendicularly to the wing's surface, the triangle of forces then being employed so as to determine the wing's lift and drag components. The lift, of course, is always known, being equal to the weight of the bird or aeroplane. According to Cayley's assumption concerning resistance direction, the wing's drag force is also known, being related to lift by the tangent of the wing's incidence angle.

However, there is a further “direct resistance” due to the bulk of the bird, or to the aeroplane’s remaining structure. This is to be discussed later. At this point Cayley encapsulates the problem of flight in the now- classic statement, often quoted, that⁽⁴⁴⁾

“The whole problem is confined within these limits, viz. To make a surface support a given weight by the application of power to the resistance of air.”

This is the first moment in aeronautical history at which such a simple, even obvious, statement is made. Nonetheless, it has to be said that the simple, the obvious, can sometimes only become so having once been stated.

Cayley then turns to the question of resistance itself, contrasting the results of Robins⁽²⁷⁾, Rouse and Smeaton⁽³³⁾ with his own conclusion which, in modern terms, amounts to the result that, for the flat plate held normal to a stream, the value of C_D is about 1.5. Incidence effects are then addressed and here, surprisingly, he does not quote his own far more appropriate whirling arm data, described above in Section 3.4, but relies on those “of the French Academy”, again a reference presumably to the results of d’Alembert et al⁽²⁵⁾. The latter, as already noted, show⁽⁴⁴⁾

“...that in acute angles, the resistance varies much more nearly in the direct ratio of the sines, than as the squares of the sines of the angles of incidence.”

He then turns to his belief in the superior lifting ability of the bird’s cambered wing and here provides a perceptive conjecture as to its cause. He suggests that, at the leading edge, the air’s upward motion over the upper surface’s convexity “creates a slight vacuity” there. Meanwhile⁽⁴⁴⁾,

“...the current is constantly received under the anterior edge of the surface, and directed upward into the cavity.... The fluid accumulated thus within the cavity has to make its escape at the posterior edge of the surface, where it is directed considerably downward; and therefore has to overcome and displace a portion of the direct current passing with its full velocity immediately below it; hence whatever elasticity this effort requires operates upon the whole concavity of the surface, excepting a small portion of the anterior edge.”

Here we meet for the first time some of the rudiments of our understanding that lift is created by the ability of a wing to remove leading edge upflow and then impart trailing edge downflow. The lift force is thus the consequent reaction on the wing due to its imposition of a vertically downward change of momentum to the air’s motion. Such ideas first emerged in their full rigour through the work of Kutta⁽⁴⁵⁾, Zhukovskii⁽³¹⁾ and Lanchester⁽³⁷⁾, whereas Lilienthal⁽⁴⁶⁾ envisaged only a downflow being created by a lifting wing. In Cayley’s supposition, however, the upflow/downflow seems to be an effect contributed largely by the under surface, whilst the upper surface adds only its “slight vacuity” near the leading edge. Nonetheless, the suggestion that an upper surface partial vacuum is achieved, and near the leading edge, is a further important advance.

Using a combination of the results of “the French Academy” and estimates based on his observations of bird-flight, in modern terms Cayley arrives at a C_L value of about 0.7 for a wing at 6° incidence. This is remarkably realistic for a modern wing of moderate camber

having an aspect ratio around six or seven (typical of that of a bird). However, this C_L value at that incidence is rather more than three times that given by his own whirling arm results for uncambered plates of unit aspect ratio. This difference might explain why his plate incidence results are not mentioned. Nonetheless, Cayley immediately applies his conclusion to a practical example, that of a machine of mass 200 lb and wing area 200 ft² (his favoured wing loading, that of the crow, is often 1 lb/ft², or about 48 N/m²). This, he believes, will fly at 6° incidence and at a speed of 35 ft/s (10.7 m/s). The thrust required to overcome wing drag he estimates, using the tangent of the incidence angle, as being about 21 lb (93 N). This implies a wing C_D value around 0.07, about double that for a modern wing of this aspect ratio but more in line with the value for a plate of unit aspect ratio. Still gripped by the idea of flapper propulsion, he remarks that⁽⁴⁴⁾,

“If therefore the waft of surfaces advantageously moved, by any force generated within the machine, took place to the extent required, aerial navigation would be accomplished.”

A little later he adds that⁽⁴⁴⁾,

“In practice, the extra resistance of the car and other parts of the machine, which consume a considerable portion of power, will regulate the limits to which this principle, which is the true basis of aerial navigation, can be carried...”

This is followed by a truly remarkable, yet frustratingly incomplete, description of a machine he has tested during that summer. He refers to this again, and in a little more detail, in the second part of his paper issued in the following year⁽⁴⁴⁾:

“Last year I made a machine, having a surface of 300 square feet, which was accidentally broken before there was opportunity of trying the effect of the propelling apparatus; but its steerage and steadiness were perfectly proved, and it would sail obliquely downward in any direction, according to the set of the rudder. Even in this state, when any person ran forward in it, with his full speed, taking advantage of a gentle breeze in front, it would bear upward so strongly as scarcely to allow him to touch the ground; and would frequently lift him up, and convey him several yards together.”

Part one of the paper gives the following additional information⁽⁴⁴⁾:

“It was very beautiful to see this noble white bird sail majestically from the top of a hill to any given point of the plain below it, according to the set of its rudder, merely by its own weight, descending in an angle of about 18 degrees with the horizon.”

Whether or not this can be claimed to have provided the first successful man-carrying glider take-off in history, the machine nonetheless appears to have been the first successful full-scale unmanned glider. In a later paper of 1843 (see Ref. 2), when apparently writing of this same machine, Cayley claims a gliding angle of about 1 in 8. If correct, this gives an L/D ratio of 8, whereas the earlier-quoted gliding angle of 18° (which could be one further misprint to add to those bedeviling the triple paper) gives the far more modest value of 3, in line with that achieved by the 1804 glider. Gibbs-Smith⁽²⁾ opts for the 1 in 8

incline. The corresponding L/D ratio around 8 is just about achievable, and at about 6° incidence, with a wing of aspect ratio around unity, the value often used by Cayley.

Part one of the triple-paper closes with Cayley's descriptions of his earlier helicopter model (Figure 18) and a suggested oscillopter design which he believes may have been similar to the machine devised by Degen.

The subject of "direct resistance" is returned to in the closing pages of part three of the paper. Cayley's attempted explanation, based on a modification of Newton's⁽²⁰⁾ 'rare medium' concept, pays scant regard to the continuity principle and is largely mistaken. However, in a return to his usual acute common sense linked to clear observation, he comments that⁽⁴⁴⁾

"It has been found by experiment, that the shape of the hinder part of the spindle is of as much importance as that of the front, in diminishing resistance. This arises from the partial vacuity created behind the obstructing body. If there be no solid to fill up this space, a deficiency of hydrostatic pressure exists within it, and is transferred to the spindle. This is seen distinctly near the rudder of a ship in full sail, where the water is much below the level of the surrounding sea. The cause here, being more evident, and uniform in its nature, may probably be obviated with better success; in as much as this portion of the spindle may not differ essentially from the simple cone. I fear however, that the whole of this subject is of so dark a nature, as to be more usefully investigated by experiment, than by reasoning..."

At that point he turns to a description of his trout-based solid of least resistance (see Section 3.10, Figure 28) and the shape of the woodcock. The experiment to which he refers at the beginning of the above passage may have been that of Du Buat⁽⁴²⁾, the only person at that time to possess a rudimentary understanding of the advantages of streamlined shapes. Hitherto, the general belief, supported by the Newtonian 'rare medium' concept, had been that it is entirely the forward shape of a body which determines resistance. And, like Du Buat, Cayley here grasps the vital point that it is the "deficiency of hydrostatic pressure" acting at the rear of non-streamlined bodies which is the main source of their resistance. However, as remarked earlier, the cause of this deficiency of pressure was to retain its "dark nature" until Prandtl's⁽⁴³⁾ illumination of it in 1904. Meanwhile, Cayley's prescription of copying nature - a suggestion also recommended independently but much later by Lanchester⁽³⁷⁾ - remained sound advice.

4.3 Stability and Control

Part two of the paper is largely an extended essay on how the principle, stated in part one⁽⁴⁴⁾,

"...must be applied, so as to be steady and manageable."

Here, then, Cayley addresses the problems of stability and control. He begins by describing the first successful parachute descent by André Jaques Garnerin (1769-1823) in 1797. Having no vent at its apex and therefore no doubt suffering alternate spillage around its canopy edge, Garnerin's parachute produced a markedly oscillatory descent. This instability

Cayley seizes on in his search for a means of providing lateral stability for aeroplanes. He believes this instability to be due merely to direct resistance differences across the canopy when tilted. Using a two-dimensional analogy, Cayley's argument is based entirely on the reduced resistance of a plate, at incidences less than normal to a stream, in comparison with the normal case. From this he argues that an inverted parachute canopy should be stable, a conclusion which he immediately applies to the aeroplane so as to suggest wing dihedral. His argument, of course, is over-simplistic and, in the aeroplane case, ignores the crucial element of sideslip. The aeroplane suffering a roll disturbance inevitably also begins to sideslip. The consequent sidewind velocity, relative to the aeroplane, therefore places the descending dihedral wing at a higher effective incidence and thus subject to a higher lift force, the reverse occurring at the ascending wing. The resulting lift imbalance between the two wings causes a moment about the centreline which rolls the aeroplane back onto an even keel. Nonetheless, using an argument carrying some credence at the time, Cayley has arrived at dihedral provision so as to enhance lateral stability.

Cayley then turns to longitudinal stability. He begins by discussing the flight of his aeroplane shown in Figure 30. In this case he assumes that the tailplane FG is set so as to carry no load.

The wing AB has its centre of pressure at C. He points out that the line of action of the wing's resistance must therefore pass through the aeroplane's centre of gravity at D. The lines EC and DE then represent the lift and drag forces, respectively.

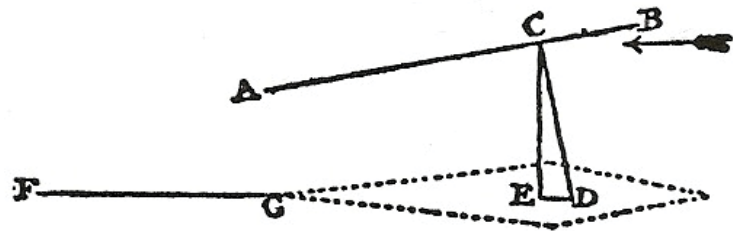

Figure 30 Cayley Glider at Trimmed Condition, 1810.

The aeroplane is thus in equilibrium under the forces and moments acting upon it. In modern terminology, the aeroplane is at a trimmed condition. He then turns to the situation in which the aeroplane becomes disturbed in pitch. Here his argument depends on two items of information.

Firstly, as implied in Figure 30, he recognises that at small incidences the wing's centre of pressure can lie forward of the wing's mid-area. His earlier work on the 1808 glider had suggested such a location and, although he had then appeared to doubt that conclusion in the closing lines of the 1808 note, here he returns to an acceptance of it. Secondly, he believes that, at 90° incidence, the resistance will act at the wing's mid-area. He therefore assumes a monotonic rearward movement of the centre of pressure with incidence increase⁽⁴⁴⁾:

“The stability...is aided by a remarkable circumstance, that experiment alone could point out. In very acute angles with the current it appears, that the centre of resistance in the sail does not coincide with the centre of its surface, but is considerably in front of it. As the obliquity of the current decreases, these centres approach, and coincide when the current becomes perpendicular to the sail. Hence any heel of the machine backward or forward removes the centre of support behind or before the point of suspension; and operates to restore the original position, by a power, equal to the whole weight of the machine, acting upon a lever equal in length to the distance the centre has moved.”

In other words, according to this argument the tail-less aeroplane is inherently longitudinally stable. Had Cayley been describing the movement of the centre of pressure on either conventional wings well beyond stall or the continually stalled flow of flat rectangular plates he would have been correct, as later experiments were to confirm. However, for the unstalled higher aspect ratio cambered wings employed later, the centre of pressure moves in the opposite direction, causing a destabilising moment which requires the compensatory moment provided by a fixed stabilising tailplane. The first persons to observe this destabilising direction of movement on the part of the centre of pressure were the Wright brothers⁽⁴⁷⁾ in testing their No. 2 glider in 1901. In the context of some of the wings used by Cayley at that time - often of low aspect ratio, of unusual planform and poorly shaped for good boundary-layer behaviour - as Potter⁽³⁵⁾ has shown for the 1804 glider, it is probable that his belief was correct. However, as to what was to come later, in the shape of high aspect ratio cambered wings, his assumption was clearly misleading.

This subject of centre of pressure movement was a further topic to retain its “dark nature” for a considerable period. Although the Wrights discovered the truth of the matter in 1901, this, like many of their findings, they kept to themselves. The aeronautical world only learned of their discovery at the release of their collected papers⁽⁴⁷⁾ in 1953. By that time, of course, the matter was well understood as a result of the aerofoil theory of, for example, Kutta⁽³⁰⁾ in 1910. That is not to suggest, however, that the point was grasped immediately. It was some years after the First World War that the British, for example, grafted the idea, in the form of a correct wing pitching moment coefficient, onto the small disturbance stability theory begun by Bryan and Williams⁽⁴⁸⁾ in 1903 and extended by Bryan⁽⁴⁹⁾ in 1911.

In the first of these references experimental results for flat plates only were used to describe the centre of pressure’s movement - therefore in the context of high aspect ratio cambered wings the wrong direction of movement was assumed - whereas in the second reference such variations were ignored altogether. Nonetheless, as early as 1914 Lanchester⁽⁵⁰⁾ was drawing attention to recent experimental results showing the forward movement of a cambered wing’s centre of pressure. Not only did these results indicate an asymptotic trend towards the quarter chord point but Lanchester⁽⁵⁰⁾ was also stressing the importance of this with regard to stability, suggesting, in effect, that the centre of gravity should lie always ahead of that point. From the point of view of ease of control, of course, such a suggestion would result in an overlarge static margin.

Despite Cayley’s failure to grasp the stabilising function of the tailplane at this stage, he nonetheless realises the necessity of having a movable horizontal tail surface for the purposes of re-trimming for different flight speeds [my explanatory additions in brackets]⁽⁴⁴⁾:

“From a variety of experiments upon this subject I find, that, when the machine is going forward with a superabundant velocity, or that which would induce it to rise in its path, a very steady horizontal course is effected by a considerable depression of the rudder [tailplane at higher positive incidence], which has the advantage of making use of this portion of the sail in aiding the support of the weight. When the velocity is becoming less, as in the act of alighting, then the rudder must gradually recede from this position, and even become elevated [tailplane at negative incidence], for the purpose of preventing the machine

from sinking too much in front, owing to the combined effect of the want of projectile force sufficient to sustain the centre of gravity in its usual position, and of the centre of support approaching the centre of the sail.”

A further interesting point here is that Cayley’s tail adjustments seem consistent with his assumed centre of pressure movement, as suggested by Potter’s tests⁽³⁵⁾.

A further function of the tail, as Cayley sees it, is for steering⁽⁴⁴⁾ [my explanatory addition in brackets]:

“The powers [moments] of the machine being previously balanced, if the least pressure be exerted by the current, either upon the upper or under surface of the rudder, according to the will of the aeronaut, it will cause the machine to rise or fall in its path, so long as the projectile force is continued with sufficient energy.”

The point here, which Cayley appears not quite to grasp, is that a supposed ‘steering’ in the vertical plane, using a movable elevator, does not necessarily steer the aeroplane in the intended direction but merely changes the pitch angle. For example, up-elevator raises the nose, the C_L , but also the C_D and therefore the drag, so that the aeroplane will ultimately slow down and begin to sink. Greater thrust also will be needed (yet this could be used alone to make the aeroplane climb). Recognition of this last requirement might be implied at the close of Cayley’s statement.

As to the further requirements of the tail unit⁽⁴⁴⁾:

“This appendage must be furnished with a vertical sail, and be capable of turning from side to side, in addition to its other movements, which effects the complete steering of the vessel.”

Again the emphasis is on steering. Here there is no hint of recognition either of the requirement for a fixed vertical fin to provide weathercock lateral stability or that a movable rudder’s primary function is to change the yaw angle. Thus at this stage, contrary to what has been supposed⁽⁵⁾, Cayley has failed to grasp the stabilising function of the tail’s fixed surfaces and is rather limited in his understanding of the functions of the tail’s movable surfaces. Moreover, as Gibbs-Smith⁽⁵⁾ allows, that vital additional control in roll for a correctly banked turn completely eludes him. Indeed, this last and vital control function had to await the Wrights’ introduction of wing warping in their kite experiment of 1899⁽⁴⁷⁾.

4.4 Structure

Cayley’s thinking on structural design is contained entirely within the third part of the triple-paper, this being otherwise largely devoted to flapper propulsion systems. And it is in his concern with the latter that it is possible to detect some of the reasons for Cayley restricting himself to wings of low aspect ratio. Because he wishes such wings to serve also as flappers, he is concerned for the loading applied when they are so used and

therefore favours wings of generally short span. Nonetheless, expanding on his brief structural note of 1808 (see Section 3.9), he offers the following general principles⁽⁴⁴⁾:

“Diagonal bracing is the great principle for producing strength without accumulating weight; and, if performed by thin wires, looped at their ends, so as to receive several laps of cordage, produces but a trifling resistance to the air, and keeps tight in all weathers. When bracings are well applied, they make the poles, to which they are attached, bear endwise. The hollow form of the quill in birds is a very admirable structure for lightness combined with strength, where external bracings cannot be had; a tube being the best application of matter to resist as a lever; but the principle of bracing is so effectual, that, if properly applied, it will abundantly make up for the clumsiness of human invention in other respects; and should we combine both these principles, and give diagonal bracing to the tubular bamboo cane, surfaces might be constructed with a greater degree of strength and lightness, than any made use of in the wings of birds.”

Cayley’s suggestion of diagonal wire bracing coupled to his earlier ideas on hollow tubular members proved apt advice, as later constructors were to demonstrate. Yet Cayley, like those before him and indeed many after, is rather optimistic in his belief that cordage “produces but a trifling resistance”. However, he is concerned for the resistance produced by the thicker structural members. In commenting on an exposed shaft used in one of his wing structures, he notes that this⁽⁴⁴⁾

“...is the only part that opposes much direct resistance to the current, and this is obviated in a great degree by a flat oval shape, having its longest axis parallel to the current.”

5.0 THE KITE-BASED GLIDER AND WHIRLING ARMS OF 1818

After the publication of the triple-paper, Cayley turned to a variety of other activities. He retained his interest in aeronautics but concentrated mainly on airships and ornithopter designs. Indeed, he remained largely silent on the aeroplane until prompted to return to it by the publication of Henson’s design for his ‘Aerial Steam Carriage’ in 1843. However, before that year two small items relevant to the aeroplane problem appear in the Cayley papers.

5.1 The Kite-Based Glider of 1818

In a letter to Lord John Campbell, dated January 1818, Cayley briefly describes one of his recent kite-winged gliders and includes sketches of it (Figure 31). The dihedral shown in the sketch is referred to in the letter but, as to the centre of gravity location and tail setting, he merely recommends⁽²⁾ [my emphasis in italics]

“...a weight to fasten to the middle stick till it will sail from the top of a hill slanting to the bottom, with perfect steadiness, obeying the rudder *which should be turned a little up...*”

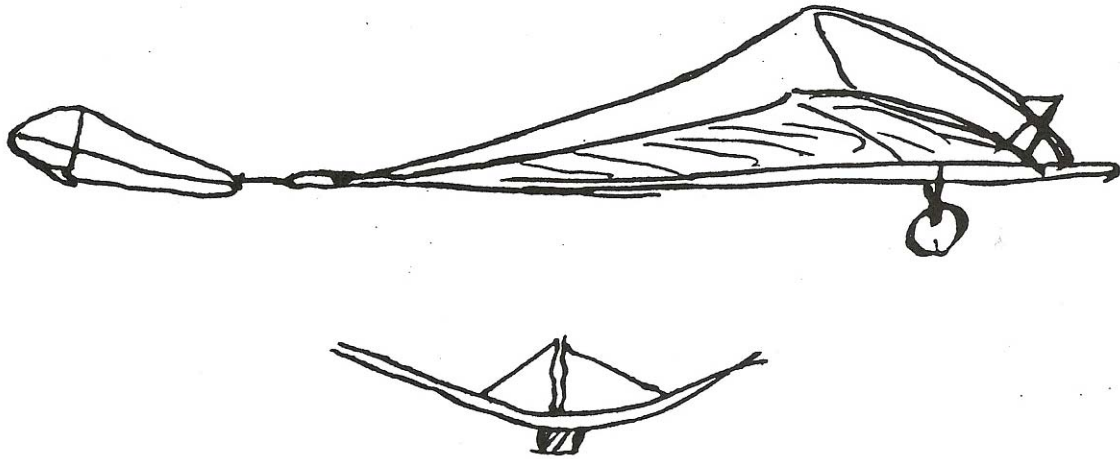

Figure 31 Cayley Glider, 1818.

The tailplane's negative setting is indicated in the sketch. It seems probable that this setting, enhanced by wing downwash, resulted in a tailplane download creating its nose-up moment at the glider's trimmed flight condition. Thus at this condition the wing's centre of pressure would have been behind the centre of gravity, the latter probably being well forward, so as to create a compensatory nose-down moment. Apart from dihedral and this tail setting, the glider is very similar to that of 1804. The interesting point is Cayley's probable choice of a tail download here. This happens to be the tail load direction usually to emerge from trim and stability conditions for conventional modern aeroplanes so as to cope with their range of flight speeds. All such considerations, of course, could not have been known to Cayley.

Moreover, from Potter's tests⁽³⁵⁾ we know that on Cayley's 1804 glider – and this may well have been the case for the 1818 glider - the centre of pressure moved in the opposite direction to that found on the modern wing. Nonetheless, various possibilities emerge for his choice of tailplane setting. As his discussion on trim for different flight speeds reveals in part two of the triple-paper (see Section 4.3 above), by 1809 Cayley knew, in effect, that he could re-trim the 1804 glider and any of its descendants for different C_L values, speeds, and gliding angles, simply by changing the tailplane and centre of gravity settings. Perhaps in the case of the 1818 glider he desired to search for smaller gliding angles which would carry the glider further across the bowl shape of Brompton Dale and which we now know would have resulted in higher L/D ratios. Alternatively, he may have felt that a downloaded tailplane produced a more stable response to gusts. Such possibilities, of course, are no more than speculation.

However, this negative setting of the tailplane was to be retained for the remainder of his involvement with the aeroplane. It was to be adopted by such subsequent constructors as Alphonse Pénaud, the term "longitudinal dihedral" being coined both to describe it and to justify its use. As to the stability of the 1818 glider, the only other evidence to hand is Sproule's⁽⁷⁾ comment on his replica of it that it was "a wonderful performer", from which we may assume stability.

5.2 The Second and Third Whirling Arms of 1818

Cayley's notebook⁽²⁾ entries from the same year as the 1818 glider contain sketches of two further whirling arms (Figure 32). Both are symmetrical double arms, mechanically somewhat more sophisticated than that used in 1804. That shown at the top of Figure 32 was used to measure the drag force on normal square plates, the other being employed to measure lift on plates at incidence.

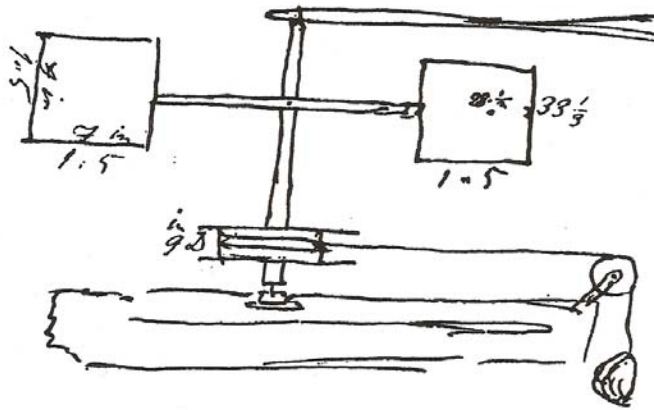

For the latter case the incidence range explored, 20° to 50°, seems hardly relevant to aeroplane work and, in the event, Ref. 2 reproduces none of any lift measurements which may have been recorded.

However, Cayley's raw data obtained from experiments in the normal plate case⁽²⁾ reduce to a C_D value around 1.4, an improvement on his earlier value of 1.5 in 1804.

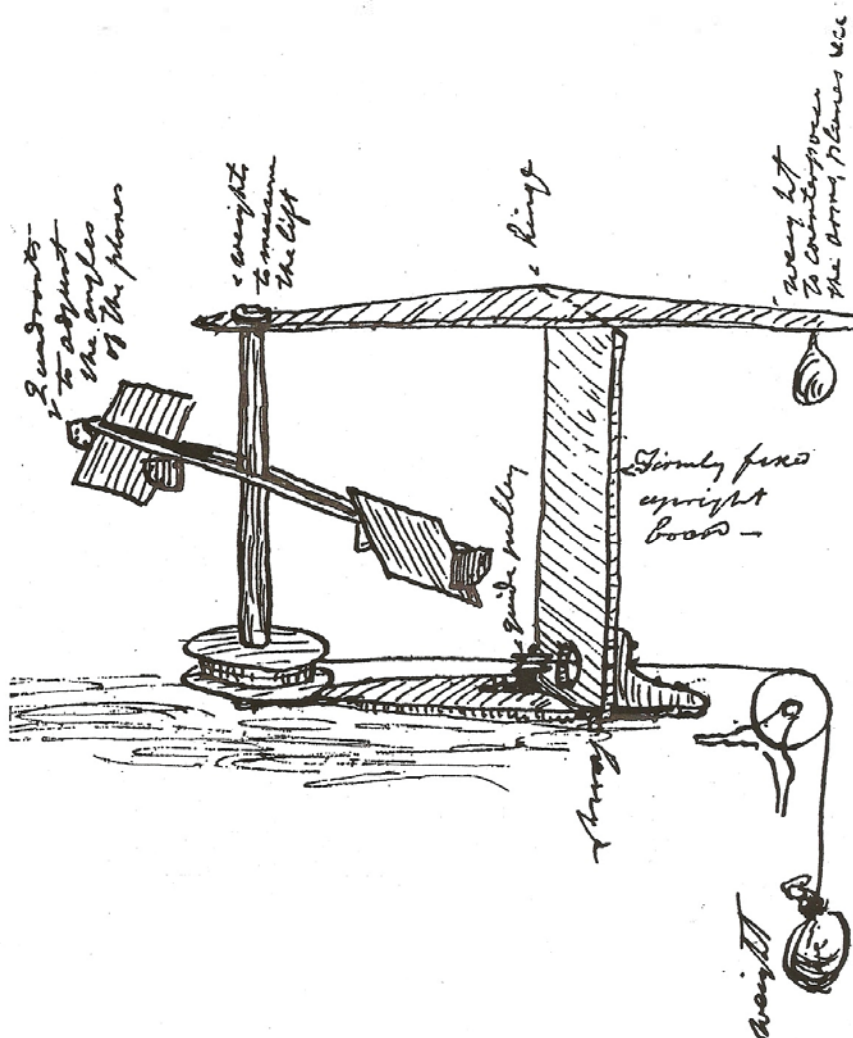

Figure 32 Whirling Arms, 1818.

6.0 CAYLEY'S RETURN TO THE AEROPLANE

After 1818, Cayley's silence on the aeroplane continued until details of Henson's design for his "Aerial Steam Carriage" emerged in 1843. Henson's patent application (Figure 33) led to an impressively illustrated, though ultimately fruitless, advertising campaign on behalf of his projected Aerial Transit Company (Figure 34). These developments renewed Cayley's interest and involvement in the aeroplane. By now he was seventy years old (Figure 35) yet, even at that advanced age, he had still much to contribute.

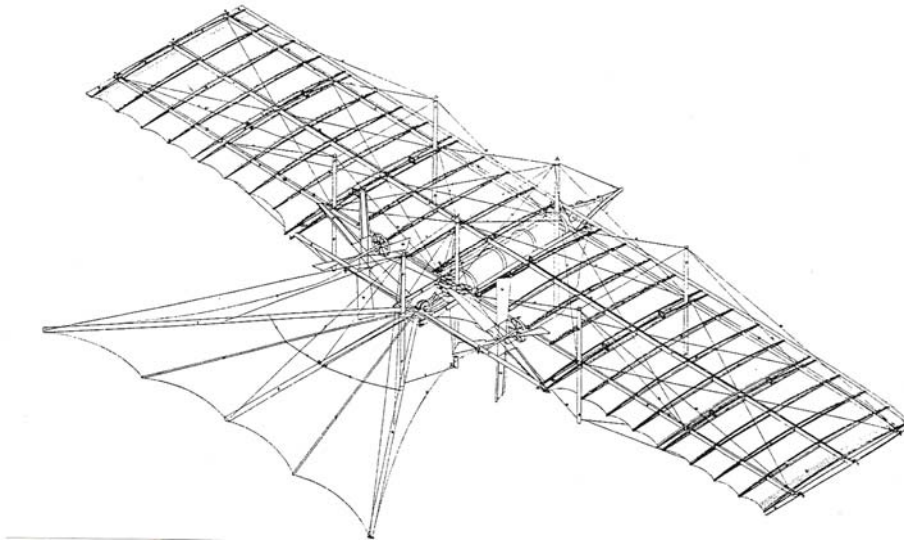

Figure 33 Patent Drawing for Henson's "Aerial Steam Carriage", 1843.



Figure 34 Engraving of the Aerial Steam Carriage in flight.
Source: Royal Aeronautical Society (National Aerospace Library).



Figure 35 Sir George Cayley, aged 70.

Source: Royal Aeronautical Society (National Aerospace Library).

6.1 The Two Papers of 1843

Cayley's immediate response to the release of the Henson design was to publish a paper⁽⁵¹⁾ in which he dealt retrospectively with many of his earlier achievements. It is here, moreover, that he states the gliding angle of 1 in 8 (and, by implication, a lift to drag ratio of 8) for the full-scale glider of 1809 which is all too briefly described in the triple-paper⁽⁴⁴⁾ (see Section 4.2 above). He also mentions for the first time an idea for a convertiplane which, as it turned out, was to be described in more detail in his next paper. The paper closes with his comments on engines, in which he mentions a heated air engine designed primarily for airship propulsion.

Cayley's second paper⁽⁵²⁾ of that year begins with a detailed criticism of Henson's design. He draws attention to the design's lack of wing dihedral but reserves his main criticism for what he considers to be an excessively large wing span. However, his doubts on the structural integrity of the wing's design prompt the following suggestion⁽⁵²⁾ (his emphasis in italics):

“If, therefore, so large a surface be contemplated... would it not be more likely to answer the purpose to compact it into the form of a *three decker*, each deck being 8 or 10 feet from the other, to give free room for the passage of the air between them?”

And with that, of course, Cayley has produced the seminal idea behind the biplanes and triplanes of the future. Cayley then turns to airships but follows this with a detailed

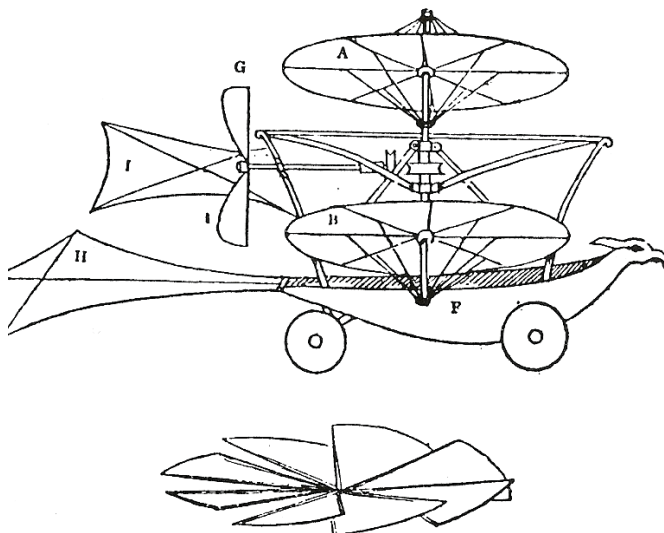
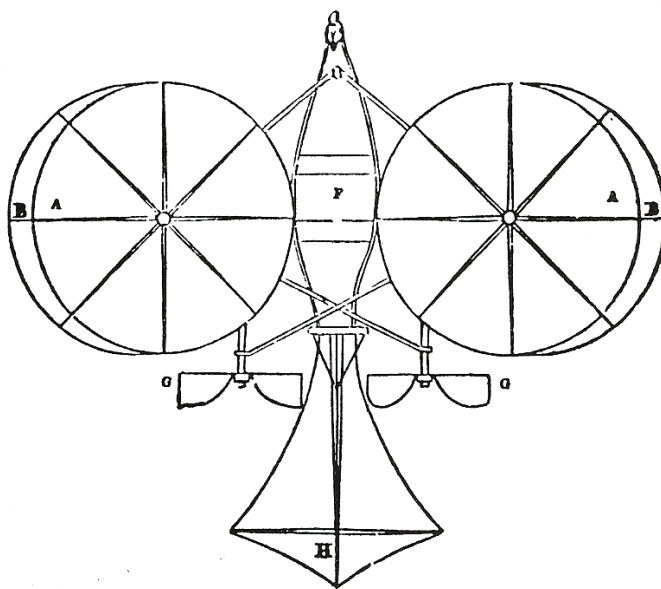
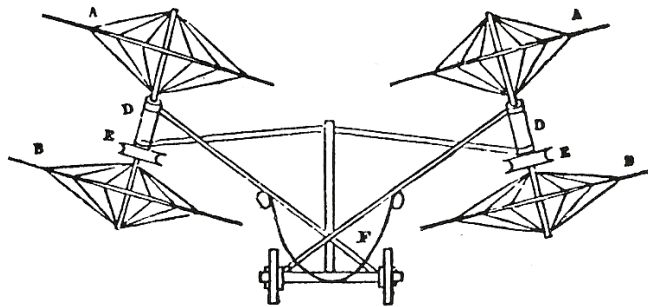

Figure 36 Cayley Convertiplane, 1843.

description of the convertiplane mentioned in his earlier paper⁽⁵¹⁾ of that year. His drawings of it are shown in Figure 36. The lifting surfaces are the four circular planform wings (aspect ratio 1.27) superposed in pairs, each surface being slightly cambered, he says, “like a very flat umbrella”. To provide lateral stability they are set at the marked dihedral angle shown. However, for ascent or descent, these surfaces open up into eight-bladed rotors, each pair on a common shaft, the latter being driven in contra-rotation by the fuselage-mounted engine. This prime mover is also used to drive the rear propellers for forward motion, a suggestion unique in Cayley’s work with the aeroplane. As to the lower horizontal tail surface, its purpose is for steering but now, significantly, it⁽⁵²⁾

“...forms also the chief means of stability in the path of the flight.”

No further explanation is given at this stage for this recognition of a tailplane’s stabilising function. The upper vertical tail surface’s function, in contrast, is referred to entirely in terms of its steering action, this to be assisted by differential use of the propellers.

6.2 The Boy-Carrier, 1849

Having suggested triplane construction in 1843, Cayley took up the idea himself in 1849, his notebook for that year recording the testing of such a machine. This is

shown (Figure 37) in his later sketch of 1853, where he refers to it as “the old flyer”. The wings have the low aspect ratio generally favoured by Cayley and also incorporate slight dihedral. Flappers were to be used for forward thrust only, perhaps driven by a heated air motor. However, the machine was first tested unpowered as a form of kite-glider⁽²⁾:

“The balance and steerage was ascertained, and a boy of about ten years of age was floated off the ground for several yards on descending a hill, and also for about the same space by some persons pulling the apparatus against a very slight breeze by a rope.”

However, the interesting feature is the duplicated tail unit, the lower unit only appearing to provide steering. The implication is that the upper unit is fixed and for stability purposes. This feature was to be repeated in a later design of 1852, for which Cayley there reveals rather more of his thinking on stability.

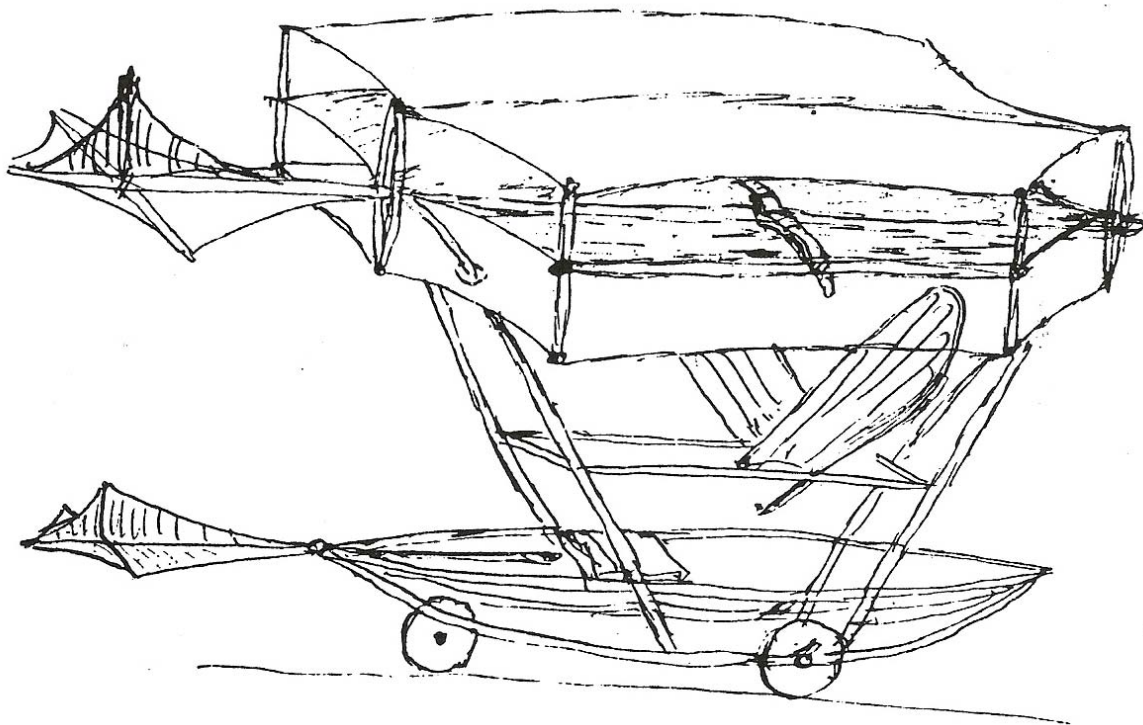

Figure 37 The Boy-Carrier, 1849.

6.3 The Model Gliders of 1849 and 1853

Cayley's notebook for 1849 records details of a new type of glider with which he⁽²⁾

“..tried some experiments with a view to ascertain with accuracy the real angle that any plane makes with its line of flight when supporting a given weight, and also the power shown to be necessary in that line of flight to sustain that weight.”

The glider is shown in his sketch (Figure 38) as having a slightly cambered rectangular planform wing of low aspect ratio, probably a value of about 1.5. The wing is fixed parallel to the pole fuselage. The tailplane is, as usual now, depressed, here by “about an angle of 8°”.

Total mass and wing area produce Cayley's favoured wing loading of 1 lb/ft^2 . Flying it, he found that⁽²⁾ [my explanatory addition in brackets]

"...a velocity of about 33 feet [per second] at an angle of 7° with the line of path (one 8^{th} of radius) sustains on 16 sq. ft. 16 lb. This agrees precisely with the weight of the crow, and his surface of wing."

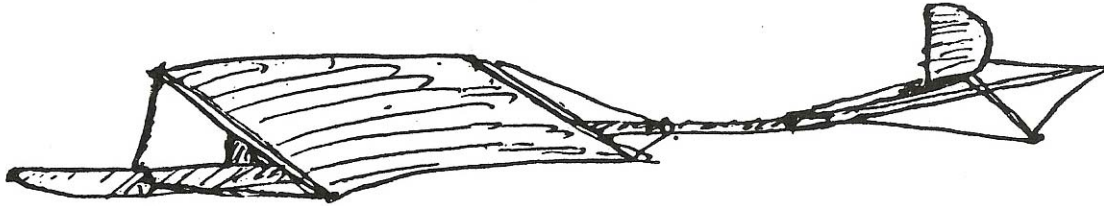

Figure 38 Glider, 1849.

The wing loading and speed give a C_L value around 0.77. This value is far too high for a wing of this aspect ratio if we are to interpret Cayley's 7° as the true wing incidence, as he seems to imply it to be in both his statement of intent and his stated result. For this C_L value a more realistic incidence would be around 17° , suggesting the possibility of a misprint. Gibbs-Smith⁽²⁾, in contrast, interprets the 7° as the gliding angle (an incline of about 1 in 8), implying an L/D ratio of about 8, again a value just about achievable with this wing aspect ratio. If correct, this suggests that, even now, Cayley may be misinterpreting wing incidence angle. An alternative possibility, as we shall see, is that some of Cayley's data are incorrect.

Some support for Gibbs-Smith's interpretation might be provided by Cayley's performance data for a very similar glider (or gliders) which appeared on the scene around 1853. The sources of these data are Cayley's notebook for that year and the paper he sent at that time to the Société Aérostatique et Météorologique de France. The relevant parts of the paper were never published since the journal foundered. Happily, however, the original text survived and is reproduced in Ref.10, some corrections being added in Ref. 2. Cayley's drawing for the French paper is shown as Figure 39a, the notebook sketches being added as Figure 39b. Although the two data sets differ slightly, the glider's rectangular planform wing, here again set parallel to the pole fuselage, had a span of 6.167 ft, chord 4.25 ft, giving a wing area of 26.2 ft^2 and an aspect ratio of 1.45. The glider's mass is quoted as being 16 lb.

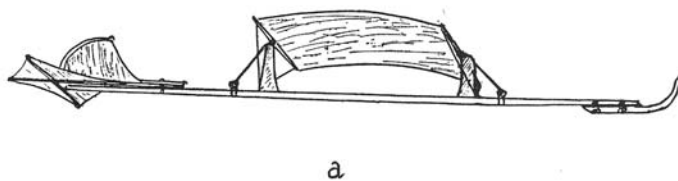

Figure 39a Glider, 1853: the French Paper

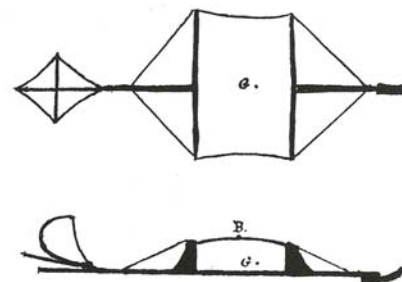

Figure 39b Glider, 1853: the Notebook

As to its performance, Cayley⁽²⁾ says [my explanatory addition in brackets]:

“When used, it is projected by hand from the edge of a hill or lofty building; and it will fly from 4 to 8 times horizontally the height of its perpendicular fall, according to the correctness of its adjustment. The rudder [tailplane] gives the most stability to the course of flight, when slightly elevated, so as to receive a small degree of pressure downwards; but when truly balanced by the weight of the prow, it flies farthest, when the rudder is in the same plane as the sail.”

Here, however, no flight speed is quoted. Despite the rather low aspect ratio, this wing is nearer in geometry to those used nowadays. In this context it is revealing to assume a drag coefficient of the form applicable strictly to wings of rather higher aspect ratio:

$$C_D = C_{D_0} + k C_L^2, \quad (1)$$

C_{D_0} being the drag coefficient at zero lift. As Lanchester⁽³⁷⁾ was the first to establish, the minimum gliding angle γ is achieved at the maximum value of C_L / C_D , at which condition

$$C_{D_0} = k C_L^2, \quad (2)$$

and
$$\tan \gamma = C_D / C_L = 2 (k C_{D_0})^{1/2}. \quad (3)$$

Using the theory outlined in Ref. 53, for example, we have

$$k = 1/(\pi A e), \quad (4)$$

where A is the wing aspect ratio and e is the aerodynamic efficiency factor, here taken to be 0.9. Thus for $A = 1.45$, k takes the value of 0.24. Given Cayley's value for the minimum gliding angle as 1 in 8, the following rather speculative estimates are obtained:

$$C_{D_0} = 0.016, C_L = 0.26, \quad (5)$$

the corresponding flight speed being, not 33 ft/s (the 1849 case cited above), but 44.6 ft/s (13.6 m/s). To attain this value of C_L (and maximum value of C_L / C_D) for a wing of this aspect ratio, the incidence might have been about 7°. This suggests that, in his 1849 tests, Cayley might have misjudged, not the incidence, but either the glider's mass or, more probably, the flight speed. For this gliding angle of 1 in 8 (about 7°), moreover, the wing would have been near-horizontal, making incidence easy to judge. The C_{D_0} value suggests that most of the drag was due to the wing itself, a result not entirely surprising in view of the vestigial pole fuselage. Cayley's statement, quoted above, to the effect that the minimum gliding angle was achieved with the tailplane set parallel to the wing, suggests, in view of the wing's downwash, that the tail actually carried a slight download. Thus the wing's centre of pressure would lie a little aft of the centre of gravity. The largest gliding angle quoted, an incline of 1 in 4, coupled to the stated even greater depression of the tailplane, suggests a centre of pressure further aft and therefore flight at even lower wing incidence and C_L values.

Cayley's additional notebook data for this (or a very similar) glider reveal a centre of gravity position about $0.34c$ (c being the wing chord) aft of the wing leading edge (see Figure 39b). Given Cayley's values for the wing and tailplane areas, together with his stated tail arm of about 10 ft aft of the centre of gravity, it is also possible to make an estimate of the glider's neutral point position. This turns out to be about $0.45c$ aft of the wing leading edge, giving an adequate static margin so as to ensure longitudinal static stability. Sproule's ⁽⁷⁾ sole comment on his replica of this Cayley glider is that it "flies beautifully", implying that the original was indeed longitudinally stable.

6.4 The Governable Parachute, 1852

Cayley's final published design for a man-carrying controllable glider – he named such gliders "governable parachutes" - appeared in the *Mechanics' Magazine* of 1852 ⁽⁵⁴⁾ (Figure 40). The monoplane wing, again of an aspect ratio a little over unity, has a planform unique in Cayley's designs and surviving records tell us little of its provenance.

However, notebook entries ⁽²⁾ give the merest hint that model tests with this planform might have been conducted. Cayley ⁽⁵⁴⁾ again recommends a dihedral angle for lateral stability, in this case an angle of between 8° and 10° . The wing's central structural member is a beam ⁽⁵⁴⁾

"...obtained by nailing and glueing together four flat pieces of timber into a hollow square, and making these taper both in width and thickness from the centre towards each end ... and this compound beam will be very nearly double as strong as the same weight of wood used as a solid square beam..."

Whether or not by now aware of the advantages of high second moments of area in the attainment of structural stiffness, Cayley again displays his earlier perception concerning tapered hollow structural members. The structure is otherwise stiffened by his usual method of wire bracing. Structural mass is given as 150 lb so that, with the mass of "the aëronaut", the total mass becomes about 300 lb (136 kg). Although no absolute dimensions are given, the wing area is quoted as being 467 ft^2 (43.4 m^2) so that the wing loading is reduced from Cayley's earlier favoured value of 1 lb/ft^2 to about 0.64 lb/ft^2 (30.7 N/m^2). If the glider were to descend vertically, literally as a parachute, Cayley estimates its terminal velocity as 16.25 ft/s. Somewhat confusingly, his next sentence reads ⁽⁵⁴⁾

"Its angular velocity may be taken at about 30 feet per second."

Gibbs-Smith's ⁽²⁾ adviser, J L Nayler, finds this comment incomprehensible and suspects an omission in the text. It may be, however, that Cayley's term "angular velocity" refers to the speed in angular descent - that is in gliding flight - and the quoted value is intended to be read in contrast to the speed of vertical descent.

In this short paper we find Cayley's final thoughts on stability. Concerning the duplicated tail unit, featured earlier on the 'Boy-Carrier', he says ⁽⁵⁴⁾

"...there are two rudders formed of horizontal and vertical sails. The larger one is, when it has once been adjusted so as to give a straight and steady steerage, to

Mechanics' Magazine,

MUSEUM, REGISTER, JOURNAL, AND GAZETTE.

No. 1520.]

SATURDAY, SEPTEMBER 25, 1852. [Price 3d., Stamped 4d.

Edited by J. C. Robertson, 166, Fleet-street.

SIR GEORGE CAYLEY'S GOVERNABLE PARACHUTES.

Fig. 2.

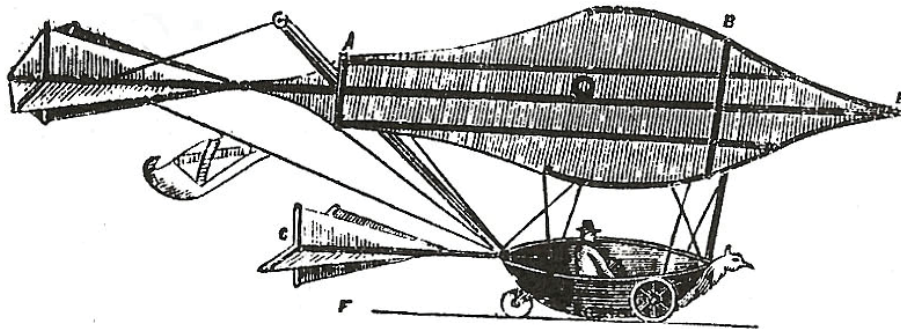

Fig. 1.

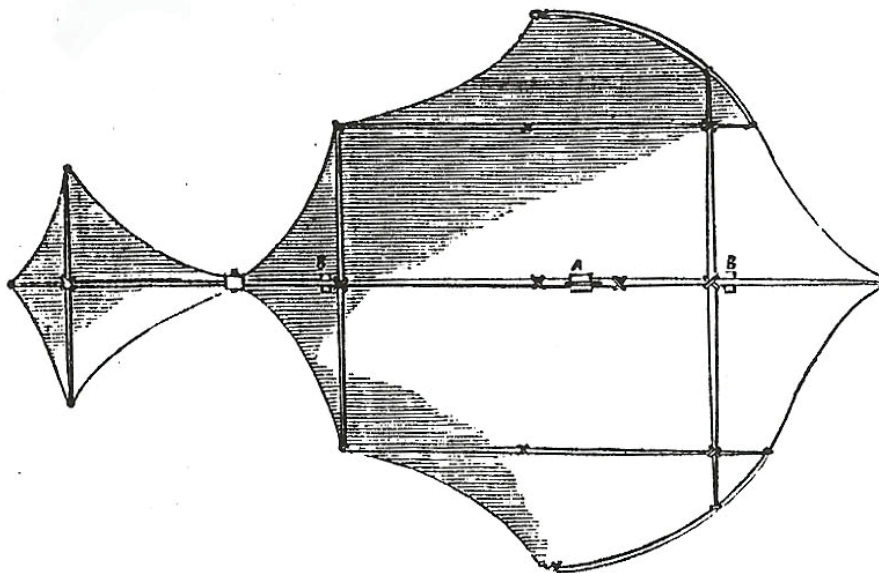

Figure 40 The Governable Parachute, 1852.

be permanently secured in that position. It gives the most steady and secure course when slightly elevated, which also tends to secure the parachute from pitching, should it be exposed to an eddy of wind, and, together with the weight of the car, immediately restores the horizontal position.”

Here at last we find Cayley's clear recognition of the stability requirement for a fixed horizontal tail surface. Again, this is to be set at slight negative incidence, suggesting a forward centre of gravity. However, there is no mention of the fact that the consequently fixed upper vertical surface will provide weathercock stability. Towards the end of the paper, Cayley adds a further comment on longitudinal stability⁽⁵⁴⁾:

“The centre of gravity of the car and its load must be so much in advance of the centre of resistance of the main sail as will incline it downward in front in an angle of 5° or 6° with the horizon. A few trials as to the required position of the permanent rudder, so as to adjust the angle of descent to be steady, will soon enable more extensive ranges to be made.”

Here he provides a rule-of-thumb which may, in effect, ensure a centre of gravity ahead of the neutral point. As to range, he anticipates a horizontal progress of about five or six times the glider's initial release altitude. This implies L/D ratios lying between 5 and 6, values which again are realistic for a wing of this aspect ratio.

Sproule's⁽⁷⁾ full-scale replica of this glider, built for an Anglia Television programme on Cayley in 1973, flew successfully at Brompton Dale. The courageous pilot was Derek Piggott. Sproule⁽⁷⁾ gives few details of the tests so that little on the glider's performance can be gleaned directly. However, he gives a wing area of 440 ft² with a span of 28 ft (Cayley's suggestion is 467 ft² but no span value is given), so that the aspect ratio is 1.8. Taking k equal to 0.2 for a wing of this aspect ratio, Cayley's anticipated minimum gliding incline of 1 in 6 together with his mass estimate of 300 lb (exceeded in the replica), equations (1)-(4) reveal the following for this flight condition:

$$C_{D_o} = 0.035, C_L = 0.42, \quad (5)$$

with a speed of 37 ft/s (11 m/s). The much higher C_{D_o} than that estimated above (equations (5)) for the 1849/1853 glider - a more than doubling in value - can be attributed to the car, pilot and extra bracing present in the Governable Parachute. Sproule⁽⁷⁾ notes that the replica's centre of gravity was set well forward, a little aft of the wing's mainspar. He adds that a one-sixth scale model of the glider, built before completion of the full-scale replica, “performed very well” with the centre of gravity in this position. Once again, it seems that acceptable longitudinal stability could be achieved. As to lateral stability, Sproule⁽⁷⁾ says,

“The machine, while extremely sensitive to wind direction in yaw, exhibited great stability in roll and lack of control in this mode did not produce problems of any kind.”

This suggests that a greater upper fin area or tail arm would have been beneficial. Piggott⁽⁵⁵⁾ has recorded his experience of flying the replica and mentions its sensitivity in yaw and a tendency to weathercock violently in the slightest crosswind. He goes on to record that initially the ground incidence was insufficient so that no take-off was achieved when towed by a car, adding that⁽⁵⁵⁾

“A quick solution was to fit a smaller rear wheel and this lowered the tail by about eight inches. Next time, off she went, flying beautifully and stably in a graceful hop. The take-off speed was still rather high and the next modification was to increase the wing incidence still further by blocking up the central fore and aft wingspar. The effect was immediate. On the next flight I climbed so rapidly that... in a matter of seconds I was up at 30-40ft, climbing at an alarming angle.”

Much of this can be seen in the Anglia Television programme recording the building and testing of the replica; regrettably however, the programme is not generally available. The replica, for many years resident at the Manchester Air and Space Museum, has now been transferred to a more appropriate home at the Yorkshire Air Museum, Elvington.

6.5 The Coachman-Carrier, c1853

The final record of Cayley's involvement with the aeroplane is the recollections⁽²⁾ of his grand-daughter, Mrs Dora Thompson, when aged about eighty. She recalled witnessing, at about the age of nine, the testing of some form of flying machine at Brompton Dale around 1853. The sole occupant of the machine was Cayley's "coachman" who, upon landing, leaped out in some agitation, crying⁽²⁾,

“Please Sir George, I wish to give notice, I was hired to drive and not to fly.”

No detailed description of this machine survives but Gibbs-Smith⁽²⁾ suggests that it was probably similar to the triplane Boy-Carrier whilst now incorporating the wing planform of the Governable Parachute. As to the identity of the "coachman", no such person having that position is listed in the Brompton census of 1851. Both Gibbs-Smith⁽²⁾ and Rivett and Matthew⁽¹²⁾ opt for the groom, John Appleby, who would have been aged about twenty at the time of the flight.

7.0 CONCLUSIONS AND RECOMMENDATIONS

It is hoped that the foregoing provides a more detailed account of Cayley's achievements. Whilst some of his advances emerge as being not quite as far-reaching as some have claimed, he retains nonetheless his immense stature as the Father of Aerial Navigation. Throughout his career with the aeroplane he retained his uncanny knack of arriving at sensible engineering solutions through a combination of keen observation and plausible argument. Although certain of his arguments have been shown to be over-simplistic, even on occasions faulty, he nonetheless arrived at many of the basic aerodynamic, structural and stability features of the successful aeroplane, tested them, and showed that they worked. As Gibbs-Smith⁽²⁾ remarks, if those who followed him had paid more attention to his findings then the progress of glider development, at least, would have been more rapid.

Two recommendations were made at the close of the 46th Cayley Lecture in 2000.

- The first was that, whilst it may suite our national taste for understatement to restrict the only memorials to this great man's efforts to a blue plaque at his

supposed birthplace and a small tablet on the wall of his workshop at Brompton, others may well see this as a national disgrace. One remedy might be to erect some more substantial memorial at Brompton.

- The second was that, considering Cayley's advocacy of education, a further, and living, memorial might be to establish Cayley Scholarships for young people of outstanding ability who wish to study aeronautics at advanced level. Funding for this should be considered by those national institutions which have benefited, and continue to do so, from his invention.

As to the first of these recommendations, Professor James Matthew of York University Physics Department and Ian Wormald, formerly a test pilot at BAE Brough, were thinking on similar lines. They advanced the cause in grand thespian style through their presentation devoted to Cayley in 2003, this being given as the Society's Sopwith Lecture and was repeated at a number of the Society's Branches and other venues. They were also involved in the establishment of the Cayley Committee at Brompton. Chaired by Ian Wormald, the Committee met at the home of one of Sir Kenelm Cayley's daughters, Belinda Evans, and her husband, Mark, a former High Sheriff of North Yorkshire. Among its other achievements, the Committee organised the well-attended celebration at Brompton Dale in July 2003. During this, Sir Richard Branson, in full Victorian garb, sailed across the Dale in a further Cayley Governable Parachute replica built, albeit with modern materials, by BAE apprentices at Brough.

Recent experience of flying this glider for a BBC television programme can be found in Ref. 56. The Brompton Dale event and the Committee's other activities, notably the arrangement by the eldest of Sir Kenelm's daughters, the late Angela, Lady Frank, to have copies of the silver disk (Figure 19) struck by the Royal Mint, provided funding which enabled Cayley's workshop to be refurbished as a museum to celebrate his work. This was formally opened in September 2010 by the Lord Lieutenant of North Yorkshire, Lord Crathorne.

As to the second recommendation, whilst there had been moves afoot to name some of the Society's student support awards as Cayley Scholarships, the term Centennial Scholarship was chosen instead.

ACKNOWLEDGEMENTS

It is a pleasure to record the generous assistance of Brian Riddle, Librarian of the Royal Aeronautical Society, and Joanne Crane of the John Rylands Library, University of Manchester. The author also wishes to record his thanks to Professor J A D Matthew, to Ian Wormald FRAeS, to Marie Belfitt of Scarborough and to Belinda and Mark Evans of Brompton-by-Sawdon for their help on matters of local history and the Cayley family.

The Cayley Notebooks, from which a number of the figures are taken, are the property of the Cayley family and in the keeping of the Royal Aeronautical Society's National Aerospace Library.

Figures.4, 18, 20, 21, 24, 26, 27, 28, 30, 31, 32, 37, 38 and 39 are from Gibbs-Smith^(2, 5) and originally from the Cayley notebooks. Figures 6 to 13, 36 and 40 are from Pritchard⁽¹⁰⁾ and originally from 19th century journals such as Nicholson's Journal, Tilloch's Philosophical Magazine and the Mechanics' Magazine. Figure 5 is from Nicholson's Journal. Sources are also given in the text when the figure is mentioned.

REFERENCES

1. ACKROYD, J. A. D. Sir George Cayley, the Father of Aeronautics. Part 1. The invention of the aeroplane; Part 2. Cayley's aeroplanes, *Notes Rec Roy Soc Lond*, 2002, **56**, (2), pp 167-181; **56**, (3), pp 333-348.
2. GIBBS-SMITH, C. H. *Sir George Cayley's Aeronautics 1796-1855*. HMSO, London, 1962.
3. HODGSON, J. E. *Aeronautical and Miscellaneous Note-Book (c. 1799-1826) of Sir George Cayley*. Newcomen Society, Cambridge, 1933.
4. HODGSON, J. E. Extracts from the Aeronautical and Miscellaneous Note-Book (c. 1799-1826) of Sir George Cayley, *JRAeS*, 1933, **37**, pp 547-568.
5. GIBBS-SMITH, C. H. Sir George Cayley, Father of Aerial Navigation (1773-1857), *Aeronaut J*, 1974, **78**, pp 125-133.
6. ACKROYD, J. A. D. *The Science of Aviation – A History*, Manchester University Television Productions, 1984. [A VHS set of this video lecture series is available from the Society's Library.]
7. SPROULE, J. Making flying replicas of Sir George Cayley's gliders, *Aeronaut J*, 1974, **78**, pp 315-319.
8. ACKROYD, J. A. D. Sir George Cayley: Inventor of the aeroplane, *Aeroplane Monthly*, 2003, **31**, (12), pp 93-98.
9. PRITCHARD, J. L. The First Cayley Memorial Lecture. Sir George Cayley, Bart. The father of British aeronautics. The man and his work, *JRAeS*, 1955, **59**, pp 79-119.
10. PRITCHARD, J. L. *Sir George Cayley. The Inventor of the Aeroplane*, Parrish, London, 1961.
11. FAIRLIE, G. & CAYLEY, E. *The Life of a Genius*, Hodder & Stoughton, London, 1965.
12. RIVETT, L. & MATTHEW, J. *A Yorkshire Genius*, Yorkshire Air Museum, Elvington, York, Second Edition, 1996.
13. DEE, R. *The Man Who Discovered Flight: George Cayley and the First Airplane*, McClelland & Stewart, Toronto, 2007.
14. KÁRMÁN, T. von. *Aerodynamics*, Cornell University Press, 1954.
15. GREEN, J. E. The future of defence and aerospace research: a view from the front, *Aeronaut J*, 2000, **104**, pp 39-46.

16. HORWOOD, T. G., SWETENHAM, J. E. & WALTON, E. R. *Guide to the Parish Church of All Saints Brompton*, 1972.
17. STOKES, P. Power for flight in the Victorian era, *Aerospace*, 1984, **11** (10), 10-18.
18. Letters, *Aerospace*, 1985, **12** (2), 27-28.
19. Letters, *Aerospace*, 1985, **12** (4), 12-13.
20. NEWTON, I. *Philosophiae Naturalis Principia Mathematica*, London, 1687. [Mathematical Principals of Natural Philosophy, Trans. Third Latin Edit. by Motte, A., London, 1729].
21. VINCE, S. The Bakerian Lecture. Being experiments on the resistance of bodies moving in fluids, *Phil Trans Roy Soc*, 1798, **88**, pp 248-254.
22. ACKROYD, J. A. D. The United Kingdom's contributions to the development of aeronautics; Part 1, From antiquity to the era of the Wrights, *Aeronaut J*, 2000, **104**, pp 9-30.
23. BORDA, J.-C. de. Expériences sur la résistance des fluides, *Mém de l'Acad Royale des Sci*, 1763, pp 358-376.
24. BORDA, J.-C. de. Expériences sur la résistance des fluides, *Mém de l'Acad Royale des Sci*, 1767, pp 495-503.
25. D'ALEMBERT, J. LE R., CONDORCET, MARQUIS DE & BOSSUT, C. *Nouvelle Expériences sur la Résistance des Fluides*. Paris, 1777.
26. EULER, L. De figura quam ventus fluido stagnanti inducere valet, *Acta Acad Sci Petrop*, 1778, **1**, pp 190-194.
27. WILSON, J. *The Mathematical Tracts of Late Benjamin Robins FRS*. London, 1761.
28. YATES, A. H. Aerodynamics in 1804: The pioneer work of Sir George Cayley, *Flight*, 1954, **51**, pp 612-613.
29. Fluid Forces and Moments on Flat Plates, ESDU Data Item 70015, 1970.
30. KUTTA, M. W. Über eine mit den Grundlagen des Flugsproblems in Beziehung stehende zweidimensionale Strömung, *Sitzungsberichte der königlich Bayerischen Akademie der Wissenschaften*, 1910, **40**, pp 1-58.
31. ZHUKOVSKII, N. E. Über die Konturen der Tragflächen der Drachenflieger, *Zeit. für Flugtechnik und Motorluftschiffahrt*, 1910, **1**, pp 281-284.
32. EULER, L. *Neue Grundsätze der Artillerie, aus dem Englischen des Herrn Benjamin Robins übersetz und mit vielen Anmerkungen versehen*, Berlin, 1745.
33. SMEATON, J. An experimental enquiry concerning the natural powers of water and wind to turn mills, and other machines depending on a circular motion, *Phil Trans Roy Soc*, 1759, **51**, pp 100-174.
34. JACKSON, H. A. J. Sir George Cayley's model glider, Project Report, Department of the Mechanics of Fluids, University of Manchester, 1984. [Jackson was awarded the Society's N. E. Rowe Medal (under 22 years of age group) in 1984 for his lecture & paper based on this work.]

35. POTTER, G.T. Investigation of the aerodynamic characteristics of Cayley's glider wing, Project Report, Manchester School of Engineering, University of Manchester, 2001.
36. WRIGHT, W. Angle of incidence, *Aeronaut J*, 1901, **5**, pp 47-49.
37. LANCHESTER, F. W. *Aerodynamics*, Constable, London, 1907.
38. ACKROYD, J. A. D. Lanchester, the Man (31st Lanchester Lecture), *Aeronaut J*, 1992, **96**, pp 119-140.
39. TIMOSHENKO, S. P. *History of Strength of Materials*, McGraw-Hill, New York, 1953.
40. TRUESDELL, C. A. *Essays in the History of Mechanics*, Springer-Verlag, New York, 1968.
41. CROUCH, T. D. *A Dream of Wings; Americans and the Aeroplane 1875-1905*. Norton, New York, 1981.
42. DU BUAT, P.-L.-G. *Principes d'Hydraulique*, Paris, 1786.
43. PRANDTL, L. Über Flüssigkeitsbewegung bei sehr kleiner Reibung, *Verhandlungen des dritten internationalen Mathematiker-Kongresses, Heidelberg*, pp 484-491, Leipzig, 1904.
44. CAYLEY, G. On aerial navigation, *A Journal of Natural Philosophy, Chemistry and the Arts*, 1809, **24**, pp 164-174; 1810, **25**, pp 81-87, 161-169. [See Ref.2 for a corrected version of the original paper which contains many misprints.]
45. KUTTA, M. W. Auftriebskräfte in strömenden Flüssigkeiten, *Illus. Aeronautische Mitteilungen*, 1902, **6**, pp133-135.
46. LILIENTHAL, O. *Der Vogelflug als Grundlage der Fliegekunst*. Gaertners, Berlin, 1889. [*Birdflight as the Basis of Aviation*, Trans Isenthal, A. W., Longmans Green, London, 1911.]
47. MACFARLAND, M. W. (Ed). *The Papers of Wilbur and Orville Wright, Vols. I, II*. McGraw-Hill, New York, 1953.
48. BRYAN, G. H. & WILLIAMS, W. E. The longitudinal stability of aerial gliders, *Proc Roy Soc A*, 1904, **73**, pp 100-116.
49. BRYAN, G. H. *Stability in Aviation*, Macmillan, London, 1911.
50. LANCHESTER, F. W. The flying machine from an engineering standpoint, *Proc Inst Civil Eng*, 1914, **98**, pp 3-96.
51. CAYLEY, G. Retrospect of the progress of aerial navigation, and demonstration of the principles by which it must be governed, *Mechanics' Magazine*, 1843, **38**, pp 263-265.
52. CAYLEY, G. On the principles of aerial navigation, *Mechanics' Magazine*, 1843, **38**, pp 273-278.
53. ANDERSON, J. D. *Introduction to Flight*, McGraw-Hill, New York, 1978.
54. CAYLEY, G. Sir George Cayley's Governable Parachutes, *Mechanics' Magazine*, 1852, **57**, pp 241-244.

55. PIGGOTT, D. Cayley flying machine, *Sailing & Gliding*, 1974, **25**, (1), February-March Issue, pp 23-26.
56. HALLIBURTON, R. & HOLBORN, D. Cayley glider returns to the sky, *Sailing & Gliding*, 2011, **62**, (4), August-September Issue, pp 22-23.

J A D Ackroyd

Born in Bradford, Yorkshire, in 1938, John Ackroyd graduated in Aeronautical Engineering in 1960 at Queen Mary College, University of London. After doctoral and postdoctoral research in shock tubes there, he joined the staff of the Department of the Mechanics of Fluids (later the Aerospace Division, Manchester School of Engineering) of the Victoria University of Manchester. He taught in aerodynamics, flight dynamics, aircraft structures and propulsion whilst carrying out research in boundary-layer theory. He retired in 2000 as Senior Lecturer. His interest in the technical history of aviation resulted in him giving the Royal Aeronautical Society's Lanchester (1991) and Cayley Lectures (2000), and the Inaugural Cody Lecture (2003). Together with B. P. Axcell and A. I. Ruban, he is co-author of *Early Developments of Modern Aerodynamics* published jointly by the AIAA and Butterworth-Heinemann (now Elsevier) in 2001.