



Accelerate your vision applications!

Performance, accuracy and energy efficiency are key parameters for machine vision solutions at the edge. Edge computing solutions facilitate data processing near the source of data generation and serve as a decentralized extension of the cloud or data center networks. This eases the integration of machine vision with lower latency and reduces bandwidth by filtering the relevant data at the edge.

Acceleration with FPGA

A standard x86 based server combined with an FPGA based off-load engine forms a powerful number crunching platform. The solution with both CPU and FPGA card coupled tightly together via PCIe offers many application acceleration opportunities. FPGAs are typically used to resolve complex calculation tasks with unsurpassed performance due to massive parallel compute capability and data-flow optimized processing. Combined with the ubiquitous choice of compute platforms a huge potential for accelerated applications is available at your fingertips. Traditionally the challenge has been the difficult programming model for FPGAs; but that is solved by AimValley's Accelerated Edge Computing team and tools.

Machine Vision applications

FPGAs enable integration of multiple distinct functionalities, resulting in higher performance and better energy efficiency. As an example, a machine vision algorithm can be combined with image stitching from multiple cameras, directly fed into the FPGA. Or, in another application, the output from an image filtering processing pipeline can be forwarded to a data store via the network directly connected to the FPGA. This architecture flexibility of FPGAs enables compact solutions, resulting in fewer components and high efficiency.

Benefits of FPGAs for Machine Vision

High Performance per watt

- Achieve high performance image (pre)processing

Ultra Low Latency

- Suitable for real-time functions

Parallel Processing

- Integration of a wide range of functions within a single FPGA

Flexible and future proof technology

- Implementation of various bus interfaces; PCIe, Gbps Ethernet, USB, CoaxPress

Benchmarking

Using benchmarking, profiling and tuning tools AimValley's Accelerated Edge Computing team quickly identifies performance bottlenecks in your existing applications and migrates the key latency or bandwidth critical sections for hardware assisted off-load to an FPGA accelerator card. Processing and throughput improvements by a factor of 5 or more are possible, depending on the algorithm; latency and power consumption can be reduced significantly when compared with graphics cards.

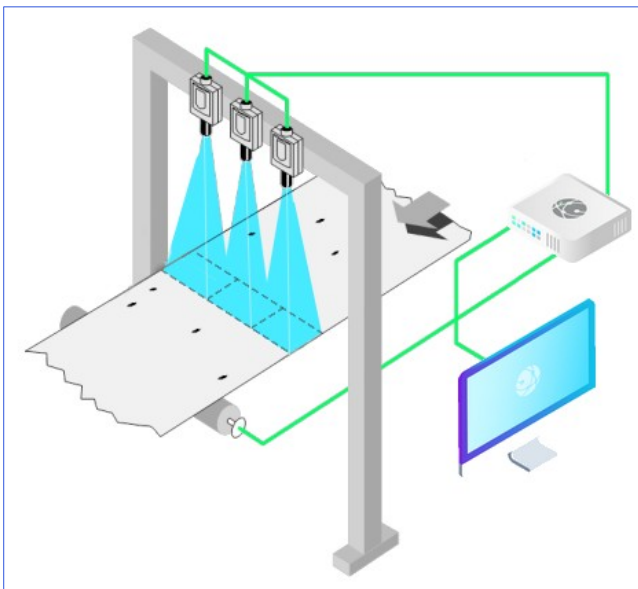

Compact FPGA-based controller for Factory 4.0

Why AimValley?

AimValley is a reliable provider of Edge technology since 2003, delivering solutions for:

- High speed data processing applications
- Complex FPGA-based accelerated systems
- High speed, low power hardware equipment
- Robust Embedded software
- Early adopter of Acceleration Technology

AimValley understands the full complexities as well as the subtle nuances of designing great edge solutions. We excel in building complex systems that are part of your product in the fields of Factory 4.0, Big Data, Healthcare and Transportation markets. Our combined skills represent all the important aspects required for the development of end-to-end systems.

Our customers enjoy the benefits of working with a strong team with more than 2 000 years engineering experience. AimValley is a trusted partner of Tier 1 customers in Telecom and Industrial markets and has shipped more than 100 000 products.

Machine Vision improves quality and productivity, while driving down manufacturing costs!

Jan Venema – CTO AimValley B.V.

Typical applications

- Automated Optical Inspection
- Motion Control Systems
- Process Automation
- Ultra Low Latency Cameras
- Vision Guided Robotics
- Quality Control
- Product tracing, scanning & identification
- Image Stabilization

Quality Focus

- Outstanding track record of on-time delivery
- Best in Class Designs – Time, Budget & Quality
- ISO9001, ISO140001, Ecovadis Platinum CSR

More information on the [Optical Flow Demonstrator](#).