

W1-3D

Monitor-Wandhalterung mit Gaslifttechnik



Allgemeine Spezifikationen

Monitorgröße	≤ 43"/≤ 49" Ultrawide Monitor
VESA Standard	VESA 75 (75x75) VESA 100 (100x100)
Maximales Monitorgewicht	8 kg 17,6 lbs
Rotation	360°
Drehgelenk	180°
Neigung	+/-90°
Distanz zur Haltestange	8-60 cm
Material	Aluminiumlegierung ADC12
Gewicht	1,65 kg
Farbe	Schwarz

Versandinformationen

Box Abmessungen	434 (L) x 129 (B) x 85 (H) mm
Brutto Gewicht	2150 g
SKU	AEMNT00032A
EAN	4895213700344
UPC	872767008618
Lieferumfang	W1-3D x1 Montage-Set x1

W1-3D

Monitor-Wandhalterung mit Gaslifttechnik

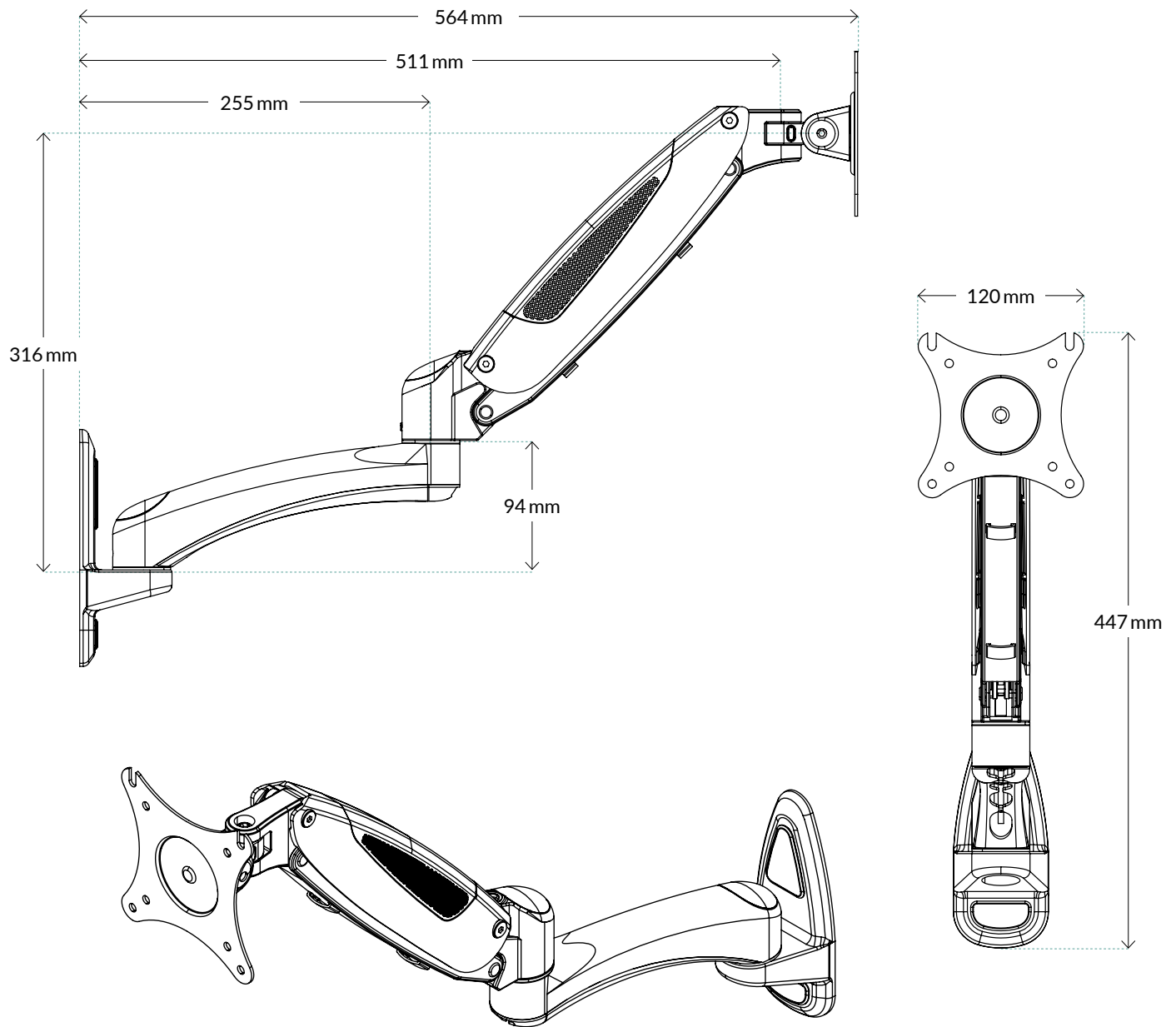

Alle Materialien sind mit den RoHS-Anforderungen kompatibel.

WEITERE INFORMATIONEN



ANLEITUNGEN

