

# Dual-Polarized Frequency Selective Rasorber with an Absorptive Band between Two Transmission Bands

JIAO Wenhan, CHANG Yumei, WANG Lin and BO Yaming  
College of Electronic and Optical Engineering, Nanjing University of Posts and Telecommunications  
Nanjing, 210023 China

**Abstract-** In this paper, we present a novel dual-polarized frequency selective rasorber. Based on an equivalent circuit model, the operation principle and design method are studied and analyzed. The rasorber exhibits an absorption band between two transmission bands. The lossy layer is achieved by introducing four resistors into a square loop slot, which contributes to the absorption band from 4.08GHz to 9.84GHz. The bottom layer is configured with a square loop slot with parasitic U-slots. Simulations are carried out and show that. From outside to inside, under the normal incidence, the insertion loss of the rasorber is about -1.23dB at 3.68GHz and -1.65dB at 9.22 GHz. In the meantime, the reflection is less than -10dB from 4.08GHz to 9.84GHz, a relative bandwidth of 83%. From inside to outside, the structure behaves as a dual-band pass filter. The insertion loss of the rasorber performance is about -1.25dB at 3.66GHz and the other one is about -1.47dB at 9.28GHz. For the two cases of oblique incidence of 30°, the rasorber can still maintain a good performance. Therefore, the proposed rasorber has a good application prospect in broadband stealth equipment with duplex communication.

**Index Terms** - frequency-selective surface (FSS), rasorber, equivalent circuit model, duplex communication.

## I. INTRODUCTION

Traditional radomes are usually composed of frequency-selective surfaces [1] for their unique spatial filtering characteristics. However, strong reflection usually exists outside the passband. In order to solve this problem, a new concept named rasorber (Radome + Absorber) is proposed to reduce the RCS in recent year, which combines the functions of FSS radome and radar absorber in a single structure and it is also called as frequency selective rasorber (FSR) [2]. FSR is actually a periodic structure, which can transmit signal in a certain frequency and absorbs electromagnetic waves in adjacent frequency bands. It is very desirable. Besides, the absorption selective transmission structure (AFST) [3] has the characteristics of absorption - transmission - absorption.

For dual-band duplex communication, the strong reflection between the two passbands greatly increases the radar cross section of the target. In order to realize dual-frequency duplex communication, the radome should be with characteristics of transmission-absorption-transmission. When the structure is irradiated by incident electromagnetic waves, useful signal at the

transmission bands can freely pass through the radome with low reflection and high transmission; while signals between the two transmission bands is largely absorbed by the structure, which means that the target inside the structure can still communicate with outside, but undetectable by the enemy radar.

Because of the structure is designed for duplex communication, the structure should also have the characteristics of dual pass band as a special radar radome. Effective communication between the inside and outside must work at at these two bands.

In this work, a polarization-insensitive dual-band FSR is designed and analyzed. Under normal incidence, the proposed FSR shows low reflections from 3GHz ~ 10GHz approximately, with two pass bands at 3.68 GHz and 9.22GHz separately. In the meantime, an absorption window from 4.08GHz to 9.22GHz is obtained between the two transmission bands. When the signal was transmitted from inside to outside, This structure exhibits a dual pass band at 3.66GHz and 9.26GHz, and the losses in these two bands are -1.25dB and -1.51dB respectively.

## II. EQUIVALENT CIRCUIT ANALYSIS

The proposed FSR structure consists of a lossy layer on the top, and an aperture FSS at the bottom, while the two layers are separated by air, as shown in Fig.1; and the equivalent circuit is described in Fig.2.

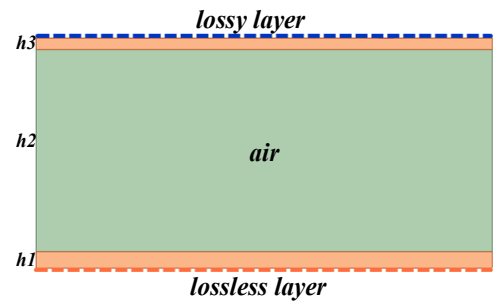

Fig. 1. Side view of the rasorber design (Physical dimensions:  $h_1=0.8\text{mm}$ ,  $h_2=9.6\text{mm}$ ,  $h_3=0.6\text{mm}$ )

Generally, there are two kinds of design for the lossy layer, one is the resonant circuit loaded with lumped resistance, and the other one is made of resistive patch. Since the patch resistance has influence on the bandwidth, and might be unfavorable to the

transmission performances at high frequencies [4], we choose the first design in this work.

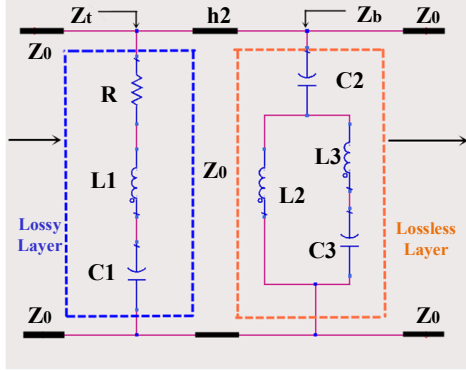

Fig.2. Equivalent circuit model of the proposed rasorber

On considering the fabrication complexity, we use air spacer to separate the top resistive layer and the bottom transmission layer, which means:  $Z_{sub} = Z_0$ . According to the equivalent circuit theory, the ABCD matrix of the FSR can be concluded as:

$$\begin{pmatrix} A & B \\ C & D \end{pmatrix} = \begin{pmatrix} 1 & 0 \\ 1/Z_t & 1 \end{pmatrix} \begin{pmatrix} \cos\theta & jZ_0 \sin\theta \\ j\frac{\sin\theta}{Z_0} & \cos\theta \end{pmatrix} \begin{pmatrix} 1 & 0 \\ 1/Z_b & 1 \end{pmatrix} = \begin{pmatrix} \cos\theta + j\frac{Z_0}{Z_b} \sin\theta & jZ_0 \sin\theta \\ \left(\frac{1}{Z_t} + \frac{1}{Z_b}\right) \cos\theta + j\left(\frac{1}{Z_0} + \frac{Z_0}{Z_t Z_b}\right) \sin\theta & \cos\theta + j\frac{Z_0}{Z_t} \sin\theta \end{pmatrix} \quad (1)$$

Based on network analysis [5], the scattering parameters of  $S_{11}, S_{21}$  can be calculated as:

$$S_{11} = \frac{P + j(Z_t - Z_b - Z_0) \tan\theta}{P + 2Q/Z_0 + j(Z_0 + P + 2Q/Z_0) \tan\theta} \quad (2)$$

$$S_{21} = \frac{2Q}{(Z_0 P + 2Q) \cos\theta + j[Z_0(Z_0 + P) + 2Q] \sin\theta} \quad (3)$$

Where  $P = Z_t + Z_b, Q = Z_t Z_b, \theta = \beta p = 2\pi f p / c, f$  is the operating frequency, and  $c$  is the light speed in vacuum.  $h_2$  is the quarter wavelength at 4GHz.

To realize the expected absorption band between the two transmission bands,  $S_{11}$  should be always be equal to zero in the operation band, and  $S_{21}$  should be equal to one at the beginning and the ending of the operation band.

Fig.3 then shows the configuration of our design. The lossy layer is realized with printed square loops on a substrate, and four lumped resistors are loaded at each side of it; the lossless layer is made of square loop slots with parasitic U-slot at the bottom of the base layer, which the larger square loop slot contributes the lower operation transmission band, and the U-slot contributes the higher transmission band.

One thing should be considered that is the resistance of the lossy layer. The resistance has an effect on the overall reflection

of the structure in all band, which is inevitable in practical design. However, we hope that the design has a large absorption effect within a certain range rather than a large loss in all bands; therefore, a balance between absorption and transparency in the design is necessary.

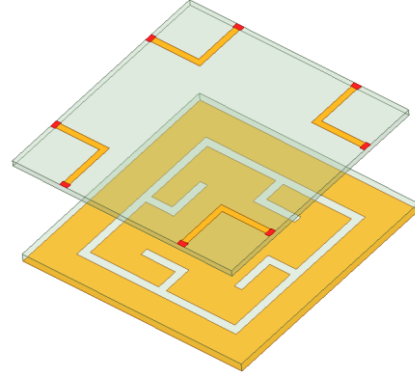
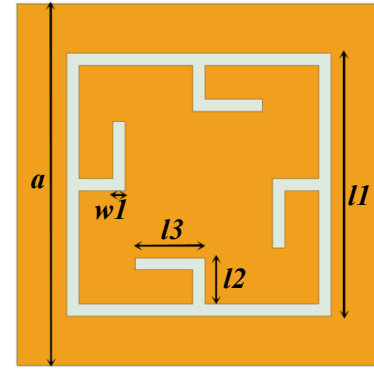
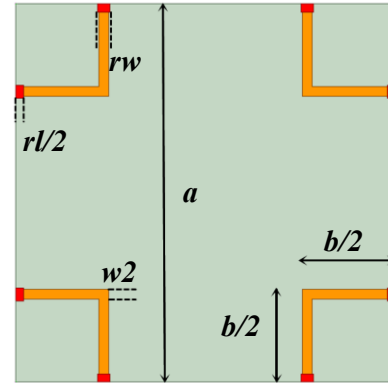

Fig. 3. Perspective view of the unit cell structure of original rasorber



(a) Lossy layer at the top



(b) Lossless layer at the bottom

Fig.4. Configurations of the top and bottom layer (The optimized parameters are:  $a=22\text{mm}, l1=16.5\text{mm}, l2=3\text{mm}, l3=3.6\text{mm}, w1=0.8\text{mm}, rw=0.8\text{mm}, rl=1\text{mm}, w2=0.6\text{mm}, b=12.2\text{mm}, r=100\Omega$ )

The structure is analyzed and simulated in Ansys HFSS 2018 software, all parameters analysis are carried out and presented.

The whole structure consists of two different substrate layers separated by air, and the whole structure is kind of like a three-layer sandwich type. The parameters  $h_1$  and  $h_2$  denoted the thickness of the substrates of the lossy and lossless layers. Detailed configurations of the two layers are shown in Fig.4, while the top substrate layers is with a dielectric constant of  $\epsilon_r = 2.65$  and  $\tan\delta = 0.003$ , while FR4 ( $\epsilon_0 = 4.4$ ) is chosen as the substrate of the bottom layer.

### III. SIMULATION RESULTS AND DISCUSSIONS

Fig.5 shows the transmission, reflection and absorption performance of the FSR under the normal incidence.

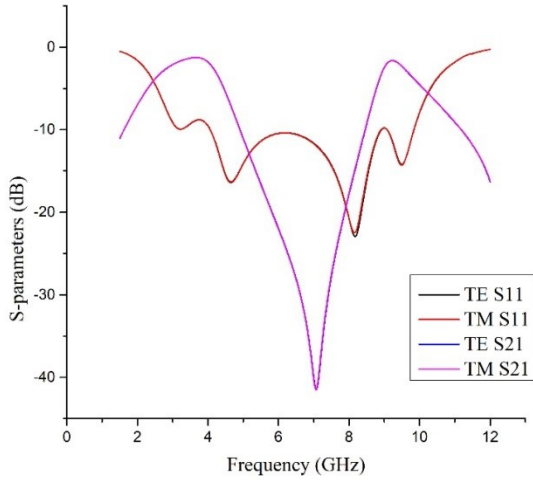

(a) Transmission and reflection of the FSR under the normal incidence

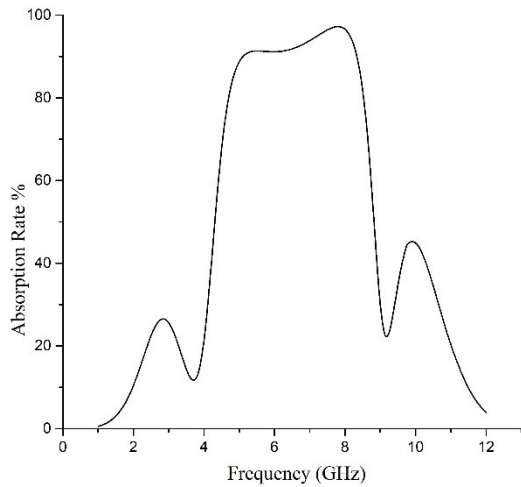

(b) Absorption of the FSR under the normal incidence  
Fig.5 Performance of the prosed FSR

The absorption rate in percentage can be calculated as follows:  
Absorption Rate =  $(1 - |S_{21}|^2 - |S_{11}|^2) * 100\%$  (4)

It can be seen from Fig.5 that, under the normal incidence, the  $S_{11}$  below -10dB is from 4.08GHz to 9.84GHz; besides, the absorption rate that over 90% is approximately from 5.10GHz to 8.34GHz. Two transmission bands are realized at two frequencies around 3.68GHz and 9.22GHz. The minimum insertion losses at the two frequencies are -1.23dB and -1.65dB separately. In addition, all simulation data are based on TE polarization.

Fig.6 shows the performance of the structure at oblique incidence. From Fig.6, we can see that, the insertion loss at high frequencies is increasing, and a grating lobe is introduced, which means that the transmission characteristic, especially at higher band, becomes more and more unstable along with the increasing of the oblique incident angle. However, when the incident angle is less than 30 deg., all the performance are very stable.

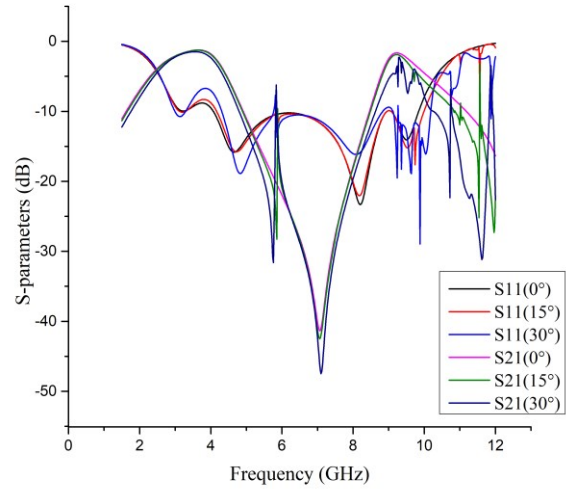

Fig.6. simulated results of the rasorber under 0-30° incidence

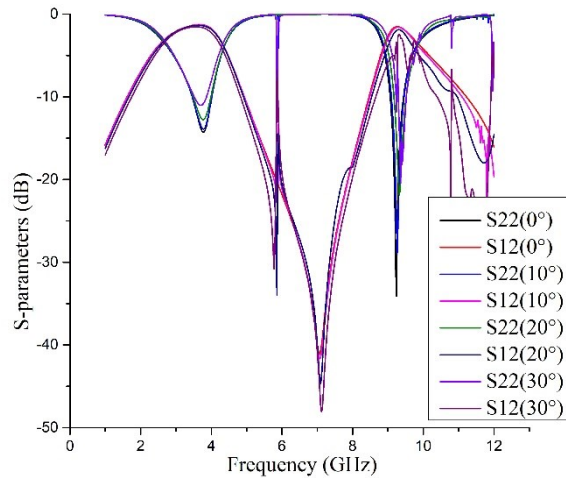

Fig.7. S22&S12 of the rasorber under 0-30° incidence of TE polarizations

As for the case of reverse incidence, i.e. when the structure is irradiated from inside to outside, the incident wave firstly passes through the lossless layer and then through the lossy layer, which contributes to the reflection band from 4.08GHz to 9.84GHz. In this case, the structure cannot guarantee the rasorber properties, but retain the performances of dual-band pass filters with center frequencies of 3.66GHz and 9.26GHz respectively. However, it does not affect the performance of duplex communication. Moreover, one can find in Fig.7 that, the angle sensitivity at higher frequency band is larger than that of lower frequency band, but the performance is relatively stable within  $30^\circ$  .

#### IV. CONCLUSION

In this work, a novel dual-polarized FSR based on a simple structure is presented and analyzed. The structure features one absorption band between two transmission bands, Simulation results show that the transmission windows are located at 3.68GHz and 9.22GHz. Moreover, an absorption band covering the two transmission bands is also achieved from 4GHz to 10GHz or so. In the case of oblique incidence of  $30^\circ$ , the proposed structure can still maintain a good performance. The novel design of the structure basically achieves the expected purpose, which provides a guarantee for the communication security of dual-frequency duplex communication, while reducing the RCS in a broad bandwidth.

#### V. ACKNOWLEDGE

This work was supported in part by the financial support of the National and Local Joint Engineering Laboratory of RF Integration and Micro-Assembly Technology (No. KFJJ20170303), Natural Science Foundation of Jiangsu Province for Youth (Grant No. BK20160912) and Natural Science Foundation of China for Youth (Grant No. : 61701256).

#### REFERENCES

- [1] B.A. Munk, Frequency Selective Surfaces: Theory and Design. New York, NY, USA: Wiley, 2000.
- [2] A. Motevasselian and B. L. G. Jonsson, "Design of a wideband rasorber with a polarization sensitive transparent window," IET Microw. Antennas Propagation, vol. 6, no. 7, pp. 747–755, Mar. 2012
- [3] A. A. Omar, Z. Shen, and H. Huang, "Absorptive frequency-selective reflection and transmission structures," IEEE Trans. Antennas Propagation, vol. 65, no. 11, pp. 6173–6178, Nov. 2017. 8-73.
- [4] Chandrika Sudhendra, Madhu AR,ACR Pillai, "Design and Implementation of A Novel Rasorber for Aircraft Stealth Applications"
- [5] D. M. Pozar, Microwave Engineering, 4th ed. Hoboken, NJ, USA: Wiley, 2012.