

Design and Development of ARM based data acquisition system for Low Frequency Signals

U Yedukondalu ¹, MSR Sekhar ², M Naga Mani ³

Dept of ECE, Aditya Engineering College, JNTU , E.G Dist., A.P

Associate Professor ¹, Associate Professor², Assistant Professor³

Project Abstract:

Embedded technology and people's lives have been closely related, but traditional data acquisition system only responds to particular signals, which is quite limited. The mean of Data acquisition is the process of sampling signals that measure real world physical conditions and converting the resulting samples into digital numeric values that can be manipulated by a computer. Simply we can say Data acquisition systems convert analog waveforms into digital values for processing.

Here the design and development of this ARM Based Data Acquisition System for Low Frequency signals objective is to acquire the data , processing ,storing and further to analyze the data using MATLAB. This system is very much compact in design, as it uses a highly integrated low power32-bit RISC microcontroller along with serial high resolution A/D converters. This Device has high performance and offers the widest range of features to control and data acquisition.

Keywords: Embedded System; Data Acquisition; ADC; ARM; EEPROM;USB

1.Introduction

The main elements of whole systems in application mode consist of transducers, signal conditioning circuit, DAQ hardware, software and computer for analyzing the data. Here the scope is to design and development of the DAQ ARM SBC board for acquiring extreme low frequency signal.

Transducers that convert physical parameters to electrical signals. So that we require signal condition for further processing. Signal conditioning circuitry includes pre amplifier and filter section. Later Analog-to-digital converters (24bit ADC) which convert conditioned sensor signals to digital values by DAQ hardware. Acquired that data will store in serial data flash card (SD/MMC). For further analyzing we need to check with MATLAB software. The data can be retrieved

from a USB device to a PC directly for getting stored data in flash card. We aim to acquire signals from 50mHz to 100Hz frequency range.

The design is to meet the needs of the naval applications to track underwater vessels from distances in shallow waters, positioning, target evaluating or for reconnaissance.

Vessels carry an underwater electric potential which is produced by cathodic currents when in contact with salt water. Mines can use this underwater electric potential to identify when to detonate.

Underwater Electric Potentials are produced by cathodic currents in the ship or submarine hull and also from propellers or other metallic materials in contact with salt water.

When the propeller is turning it generates a frequency due to corrosion current between hull and shaft. This can also be used as an input or a trigger signal in an influence mine. The ship's movement produces a Low Frequency Electric field that can be used for positioning and target evaluating.

Generally the data acquisition systems, as the name implies, are products and/or processes used to collect information to analyze some phenomenon. As technology has progressed, this type of process has been simplified and made more accurate, versatile, and reliable through electronic equipment. Equipment ranges from simple recorders to sophisticated computer systems.

2. System Overview:

The system can examine in two modes. One is performance mode (factory level) in which we can give analog sine wave signals from any function generator in the absence of transducers to ADC input for significant the performance of the system.

Block diagram of data acquisition system in performance mode

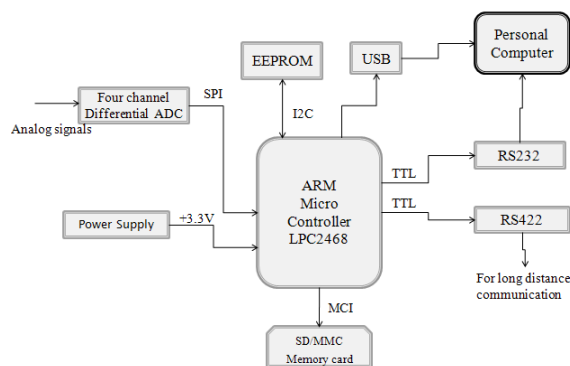

A second mode of operation is an Application mode in which we can interface transducers, pre amplifier, Low Pass Filter to DAQ card for getting the best result in a Naval

application where we want to realize/analyze the low frequency signal.

3. Transducers and Signal Conditioning:

In application mode the type of transducer used for measurement of very low underwater electric field is a polyamp carbon fiber type of sensor.

The carbon fiber sensor series is a highly sensitive, robust and long life underwater electric sensor that is used in this application.

The mechanical robustness, handling and life expectancy of sensors using carbon fiber technology make it much more versatile for these applications compared to other electrode types. Measurement Range from 1mHz to over 1KHz and signal amplitude of order of nano volts to volts.

The major advantages of the Polyamp sensor are its very low system noise and the ability to be rapidly deployed.

Signal conditioning

Signal conditioning is typically consists of a circuit to connect an analog sensor to a digital acquisition system. This circuit requires three functions the first one to linearize the output signal of the sensor, the second to amplify the signal to a degree that it falls within the ADC input range, and the third limit the signal frequency such that it does not exceed the capabilities of the digital system.

The polyamp differential amplifier/pre amplifier is used to amplify the nV signal to some mV that its within the ADC input range. This section connected to the 1KHz low pass filter for limiting the signal frequency. It filters the frequencies above 1KHz. And filtered signal is connected to the ADC. The

complete set up in application mode as shown in below:

Block diagram for Transducer and Signal conditioning

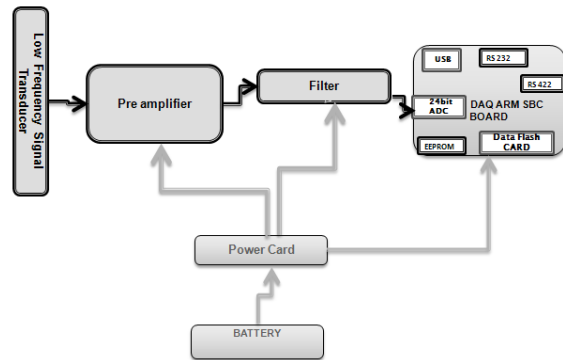

4.Main components:

This main component of this DAQ ARM SBC board consists of an ARM micro controller, 24bit ADC, SD/MMC, USB device, EEPROM and RS232 Driver and RS422 driver .

Micro controller:

The NXP micro controller is designed to provide a cost effective and high performance micro-controller solution for general applications. An outstanding feature of the LPC2468 is its CPU core, a 16/32-bit ARM7TDMI RISC Processor (72MHz) designed by Advanced RISC Machines, Ltd., Besides, LPC2468 has abundant integrated on-chip functions such as Bus Interfaces, USB, MCI interface, Watch Dog Timer (WDT), and Real Time Clock (RTC) ,SPI, I2C on chip protocols, and so on. All these features facilitate the controller's hardware and software design. Thus, the controller based on the ARM Processor can deal with much more complicated control tasks that most conventional lower computers can't deal with. So the smart processor can greatly optimize the controller's performance. The embedded

system uses FLASH and SDRAM memories for storage and program running. When the system begins to run, those source codes are moved to SDRAM for running.

ADC:

As far as, the control and acquisition system concerned, Analog to Digital Converter is essential for converting analog signal form. The ADC is designed for applications requiring high resolution measurement, where space and power consumption are major considerations. This ADC uses an SPI-compatible Serial Interface.

Interfacing circuit of MAX11040K

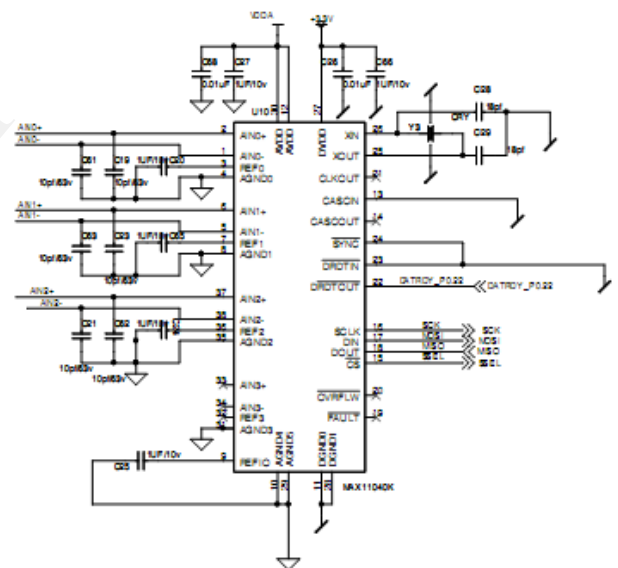

Here the system uses MAX11040K is 24 bits, four channels, simultaneous-sampling, sigma-delta analog-to-digital converters (ADCs) from MAXIM manufacturer. ADC s has four modulators simultaneously convert each fully differential analog input with a programmable data output rate ranging from 0.25ksps to 64ksps. The devices achieve 106dB SNR at 16ksps and 117dB. SNR at 1ksps (MAX11040K). The differential analog input range is $\pm 2.2V$.

EEPROM:

The Microchip Technology Inc. 24LC04B is a 4 Kbit Electrically Erasable PROM. The device is organized as two blocks of 256 x 8-bit memory with a 2-wire serial interface (I2C). **Interfacing circuit of EEPROM**

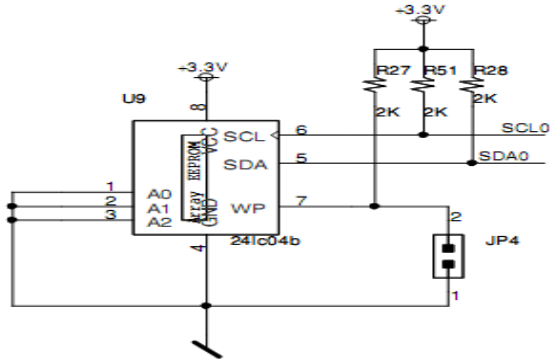

Low-voltage design permits operation down to 1.8V, with standby and active currents of only 1 μ A and 1mA, respectively. The 24LC04B also has a page write capability for up to 16 bytes of data. It is for the purpose of storing saved data file names.

SD/MMC:

The data should be stored as a record for the future reference requirements. The Secure Digital and Multimedia Card Interface (MCI) allows access to external memory cards to store acquired data from sensors in terms of files using FAT32 file system.

Serial Communication:

Communication-Based data acquisition products, those that interface with a computer through a communication port, It can range from DAQs to remote intelligent control systems. The most common communication interface for short distances is RS-232. In this system for sending user control commands from the computer to the DAQ system through RS422 communication for long distances.

USB:

The device controller enables 12 Mbit/s data exchange with a USB Host controller. It consists of a register interface, serial interface engine, endpoint buffer memory, and DMA controller. USB device retrieves the data from flash card (SD/MMC) send to PC for further analysis.

Design Flow:

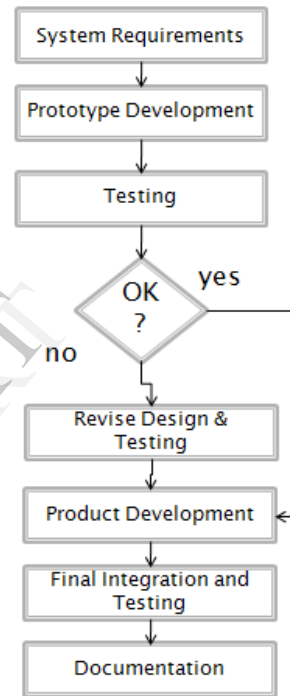

5. Software Development:

For any system Software Design is an important characteristic. Application software adds analysis and presentation capabilities to the driver software. Application software also integrates instrument control (SD/MMC, USB2.0, RS232, and EEPROM) with data acquisition. The hardware and software provide a platform for diverse control and acquisition Applications. The software tools used in this project are Keil MDK ARM, ulink debugger and MATLAB software.

Experimental setup:



6.Results and discussion:

The below waveforms are based on the inputs given from the signal generator for checking the performance of hardware. The following result is reconstruction signal using a DAQ ARM SBC board without a signal conditioning section for 50mHz,40mVpp sine wave input.

Amplitude :

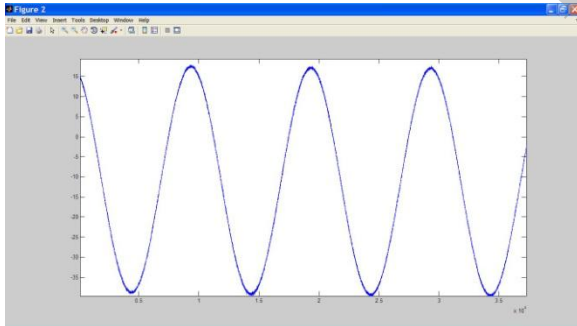

For the significant bit rate of this DAQ system is by using FFT calculation only. Here we got SNR is approximately 112dB for the above signal. So that the result is satisfactory with DAQ hardware without signal condition and filter. If we add signal conditioning and filter, we may expect more accurate result.

FFT:

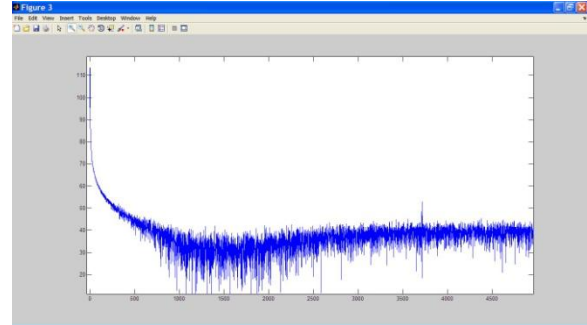

7.Conclusion

The system has a high application value in naval applications. Because the Vessel (Ship) movement produces extra low frequency electric field or signal. These low frequency signals used for positioning, target evaluating or for reconnaissance. So that development of this DAQ may use for sensing low frequency signal.

The design of the DAQ system presented here is compact in size, reliable, high-performance, low power consumption and cost effective - an Embedded Control and Data Acquisition System.

8.Acknowledgement

The work described in this paper has been supported by Essen Electronic Systems Pvt. Ltd. The authors would like to express their gratitude for the support.

9.References:

- [1] NXP micro controller LPC2468 datasheet
- [2] NXP - UM10237 LPC2468 User manual
- [3] AN10911 application note from NXP
- [4] MAX11040K datasheet from maxim-ic
- [5] 24LC04B datasheet from microchip technology Inc.
- [6] USB Complete by Jan Axelson

[7] PreAmplifier /ELFE sensors technical data from polyamp

[8] Inter-Integrated Circuit (I2C) Bus Standards, NXP.

[9] Data Acquisition fundamentals from Natioanl Instruments- Application 007

[10]D. Bishop, G. Waters, D. Dale, T. Ewert, D. Harrison, J. Lam & R. Keitel, "Development of an Autonomous 32-bit intelligent device controller," nuclear Instruments and Methods in Physics Research, Volume 352, December 1994

[11] Design & Implementation of ARM Based Data Acquisition System by Mahboob Imran Shaik-978-1-4577-1894-6/11/ ©2011 IEEE

[12] L. Gori, R. Tommasini, G. Cautero, D. Giuressi, M. Barnaba, A. Accardo, S. Carrato & G. Paolucci, "An embedded control and acquisition system for multichannel detectors," Nuclear Instruments and Methods in Physics Research, July 1999, pp. 338–346.

[13] J.C. Campelo, P. Yuste, P.J. Gil & J.J. Serrano, "DICOS: a real-time distributed industrial control system for embedded applications," Control Engineering Practice, 2001, pp. 439–447.

Authors:

MSR Sekhar:



Completed BE from AU,A.P. in 1993,MTEch from JNTU, Kakinada, A.P. in2006 And registered for PhD in JNTUK, Kakinada in 2010.Having 16 years of teaching and 5 years of industrial experience. The research area is WSNs. Currently working in the AEC , A.P as Associate professor. Developed several laboratories in different engineering colleges.

M Naga Mani:



Completed Engineering Graduation from the Institution of Engineers (INDIA) in 2005. At present pursuing MTEch in Embedded Systems from JNTU, Kakinda. She has 8 years of solid experience in Design, Development, Integration and Testing of various embedded systems like Data Acquisition Systems, naval Systems etc.