

# AN INTEGRATED ENVIRONMENT FOR MACHINE SYSTEM SIMULATION, REMOTE MONITORING AND FAULT DETECTION

Amos Ng, Leo De Vin, Martin Sundberg, Fredrik Oldefors,  
*Centre for Intelligent Automation, University of Skövde, PO Box 408, SE-541 28 Skövde, Sweden*

Philip Moore, Sanho Yeo  
*Mechatronics Research Group, De Montfort University, Leicester, LE1 9BH, U.K.*

Keywords: Simulation, remote monitoring, model-based fault detection

Abstract: Machine service and maintenance is an intricate specialist task and machine builders often have to provide worldwide service at short notice. Machine builders would benefit enormously from the possibility to monitor and diagnose equipment operating at distant locations – both for condition-based preventive maintenance and for diagnostic purposes before flying in qualified maintenance personnel and spare parts. This paper introduces an innovative virtual engineering framework that extends the kinematics modelling and dynamics modelling capability of advanced machine simulation systems to incorporate remote monitoring and fault detection features. Specifically, it addresses the software environment that is designed to facilitate the tight integration between virtual engineering tools (machine system simulation), machine controllers (real/simulated) and model-based fault detection schemes. The underlying real-time communication framework based on the publish-subscribe model and applications interfacing techniques are also presented.

## 1 INTRODUCTION

In the past, cyclically or sporadically occurring faults, which could not be identified automatically and monitored directly by fault messages of the controllers, had to be detected by visual observation (Groll 2001). In this era of globalisation, this is not desirable if the service and maintenance support is provided in a worldwide basis. It is also not applicable to machine failures for which the error symptoms cannot be repeated for observation. Video diagnosis systems and corresponding fast off-line video transmission technologies, can be seen as an enhancement to provide visual information to improve the analysis capability (Wolfram and Isermann 2002). However, this incorporates high additional cost in installing and running the video systems. Furthermore, monitoring by video can only be applied to observe a very limited number of views of an individual machine so that it falls short of the applicability for monitoring the complex machine system as a whole, where faults may occur in different locations with different components.

Alternatively, advanced kinematics modelling with realistic three-dimensional (3-D) animation feature that is nowadays commonly supported by many advanced machine simulation systems, is promising to provide users with highly visualised, meaningful and easily comprehensible information. This approach is considered to be also highly economical if the same set of simulation models, developed incrementally during the machine design and development lifecycle, can be reused. As a matter of fact, our previous research conducted in the ESPRIT project VIR-ENG (Adolfsson et al. 2000, VIR-ENG 2001, Moore et al. 2003), has proposed and successfully demonstrated the use of virtual engineering to support the entire development lifecycle of modular manufacturing machine systems, from conceptual design during negotiation and quotation stage, to the final machine commissioning phase. Depending on the level of details and equipment types, both robot simulation (RS) and discrete event simulation (DES) have been used for developing the machine system simulations that are integrated with real/simulated machine

controllers for testing and verifying the logic control software. It has been envisaged that the graphical simulation models developed incrementally during the machine development stage can be effectively applied to the operational monitoring and maintenance phase as well. In addition to the modelling capability and validity of the simulation models, the applicability and effectiveness of such an approach rely also heavily on a framework that tightly integrates virtual engineering tools (machine system simulations), machine controller (real and simulated) and model-based fault detection schemes with high-performance devices/applications communication and interfacing techniques.

Recently, research and implementation of such a new approach is undergoing in a Swedish project called MASSIVE – MACHine Service Support using Innovative Virtual Engineering at the University of Skövde with a number of major Swedish industrial companies (see Acknowledgments for the list of participants). This paper aims at presenting an overview of the MASSIVE project. Specifically, it addresses the system architecture that is designed to incorporate the tight integration between machine system simulation and other system components for remote monitoring and fault detection. It also addresses the underlying real-time communication framework that supports the interaction of the system components.

The rest of this paper is organised as follows: Section 2 briefly introduces the important modelling concepts and techniques when using virtual engineering tools for manufacturing machine system lifecycles. Section 3 reveals the designed system architecture. The underlying real-time communication framework based on the publish-subscribe model is presented in Section 4. Conclusions and outlook are given in Section 5.

## 2 VIRTUAL ENGINEERING FOR MANUFACTURING MACHINE SYSTEM LIFECYCLES

Other than the advanced kinematics modelling and realistic 3-D animation feature as mentioned previously, the capability of virtual engineering tools for the modelling of machine system logic as well as the system dynamics required for both system development and maintenance purposes should not be underestimated. The core concept behind the new approach proposed here is the separation of a simulation model into a number of sub-models including *machine/environment logic models* and the *machine dynamics models*. These sub-models can

then readily be linked to the logic control models and/or real/simulated machine controllers using hardware-in-the-loop (HIL) techniques for testing and verification. Figure 1 illustrates this concept and proposes some suitable modelling formalisms for different types of models.

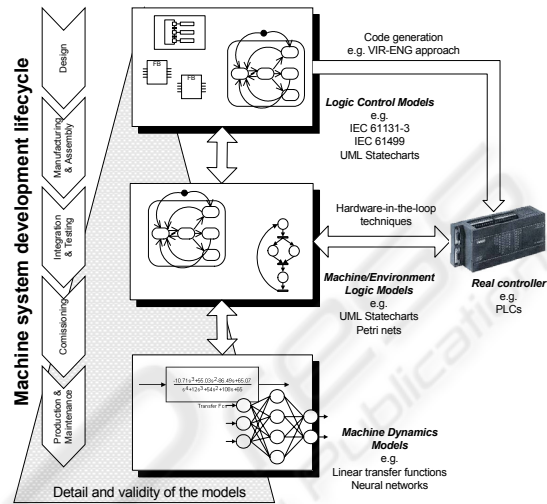

Figure 1: Modelling techniques for manufacturing machine system lifecycles.

A machine/environment logic model is a logic model that mimics the logical behaviour of the machine or process as well as part of the surrounding environment (e.g. auxiliary devices or human operators) in response to the commands sent from the logic control models/machine controllers. In return, based on the interaction of the logic model and the machine dynamics models, inputs to the logic control models/machine controllers are changed to imitate the events/signals from the feedback devices and any observable state variables of the machine system. In other words, the machine/environment logic model behaves as the virtual actuators and sensors of the controlled process. Hence, the interface for the connection to a logic control model is called virtual I/O (VIO).

After the logic control models has been fully tested and verified, control components that control the physical machines can be generated seamlessly using the VIR-ENG approach (Moore et al. 2003) or transferred to real machine controllers such as programmable logic controllers (PLCs). It is also possible to carry out tests with the real controllers against the virtual machines by replacing the virtual sensors and actuator interfaces (i.e. VIO) with the physical I/O devices, normally in a piecewise basis. It has been noticed that an identical concept has been proposed as the methodology for using the emerging IEC 61499 function blocks modelling standard to

develop next-generation state-machine controllers (Lewis 2001).

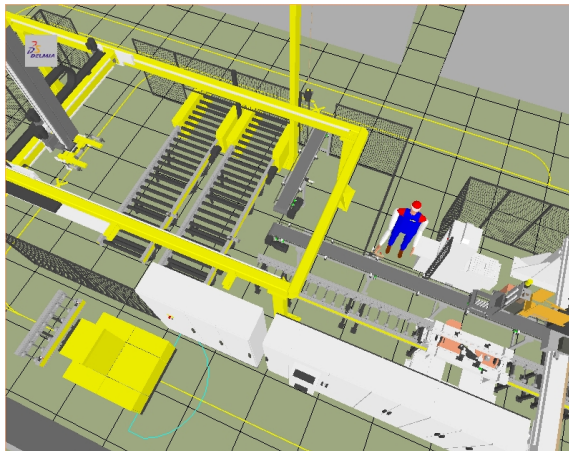

Figure 2: A simulation model for the industrial test-bed – a flexible assembly cell for automotive engines.

The above-said approach has been partially demonstrated to shorten the machine system development time significantly based on the experience from an industrial test-bed (VIR-ENG 2001) in which simulation models have been developed using RS system IGRIP, DES system QUEST supplied by DELMIA (2003)(see Figure 2). To extend the model for valid and robust fault detection further, an accurate machine dynamics model is paramount. With an observation that accurate machine dynamics is difficult to model by using physical principles, especially during the system development stage, applying system identification techniques is proposed. Linear models (Ljung 1999) or non-linear models, e.g. using neural network (Nelles 2001) can be identified using observed input-output data acquired during the machine commissioning or initial operational stage. These models can then be embedded into the machine simulation and link to a machine/environment logic model that governs which dynamics model should be invoked based on the predetermined logical structure. In a remote monitoring setting, these dynamics models act as the reference models to generate the nominal dynamic response of the system with the input data from the sampled data acquired remotely and allow comparison to actual output from the real system using residual analysis. The residual signal is useful for fault detection, as well as to isolate and assist diagnostic tasks when tracing the root cause of the fault using various residual evaluation techniques – an approach that is commonly known as model-based fault detection. While significant efforts have

already been paid to address model-based fault detection and isolation (FDI), particularly for the process industry (Chen and Patton 1999, Isermann and Ballé 1997), MASSIVE is intended to contribute a new virtual engineering framework so that existing generic or machine-specific FDI algorithms or schemes, can be tightly integrated with graphical machine simulations to provide a unique service and maintenance environment for builders of discrete manufacturing machine systems.

### 3 THE MSSS ENVIRONMENT

Within the MASSIVE project, the above-said concepts are being realised through the design and implementation of an integrated software environment called MSSS (Machine Service Support System), as an extended part of the machine design and control environments developed in VIR-ENG. A system architecture that defines various components of MSSS and their interactions has been preliminarily designed and is illustrated in Figure 3 on the next page.

#### 3.1 Data Acquisition and Transmission

MSSS is essentially a remote data acquisition and analysis system. Therefore, it is obvious to see that an advanced data acquisition, pre-processing and management framework is the foundation for all other functions. The OLE for Process Control (OPC) technology (OPC Foundation 2003) is being used for collecting discrete-event data and continuous data with low sampling rate (<100Hz) from the PLCs/soft-logic controllers or directly from the fieldbus. As the de-facto standard for application interface to control devices in the industrial automation sector, OPC is supported by virtually all automation suppliers and therefore offers seamless data access solution without the need of developing customised software drivers. Nevertheless, dedicated sensory and high-speed data-acquisition devices might be required if high sampling rate is required for collecting continuous data such as electric current.

The data acquisition system can be remotely configured so that specified parameters, machine process variables, discrete-event signals can be acquired in prescribed time intervals and sampling rates. Configurations for routine periodic data logging can also be selected for day-to-day monitoring. All configurations to the data acquisition components are done through the *Web*



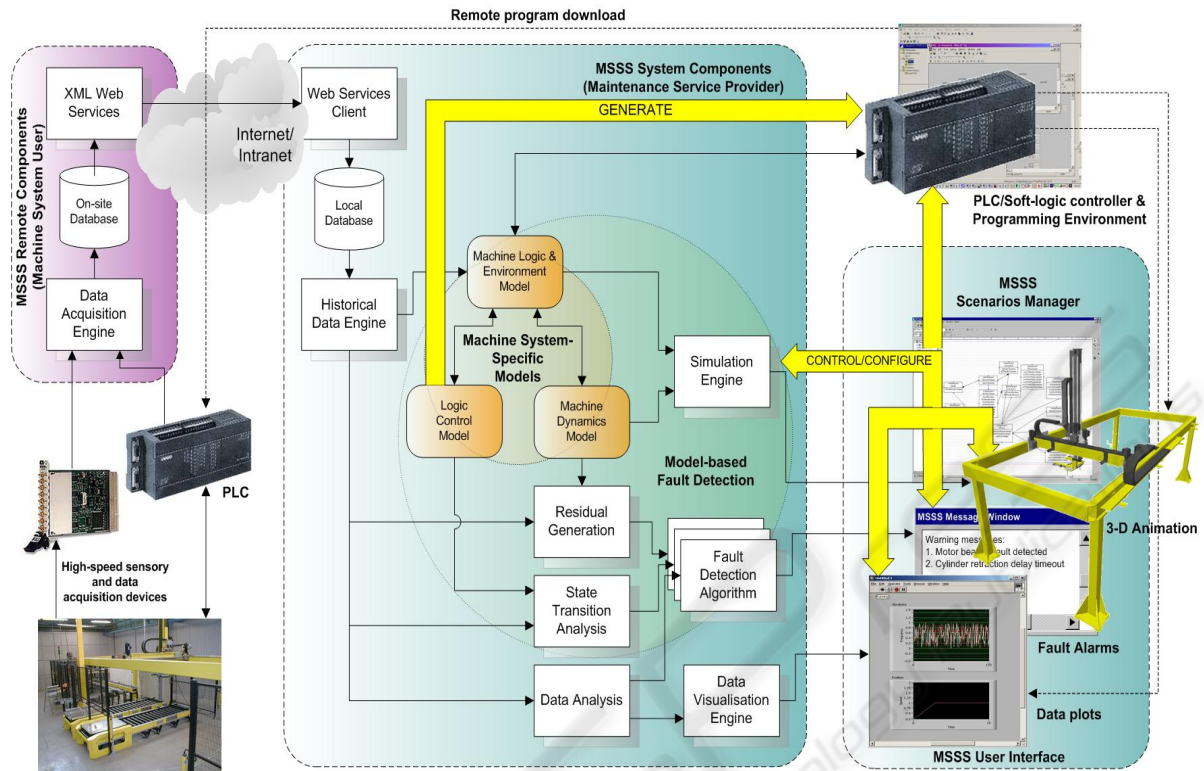

Figure 3: The MSSS environment.

methods provided by the XML Web services using the user interface functions provided by Scenario Manager (see Section 3.4). Implicitly, the term “Internet/Intranet” in the system architecture implies that a single solution can be applied readily into both on-site and off-site machine service scenarios. This also facilitates a common user interface for local and remote monitoring, day-to-day and “on-demand” specialist maintenance. Currently, the web services are being developed using the Microsoft ASP.NET (Active Server Page) technology. The ASP.NET security and Windows authentication scheme have been enforced to disallow unauthorized access to the web services.

### 3.2 Monitoring and Fault Detection

For continuous visual monitoring or in the case of a machine failure (breakdown), MSSS users can use the historical data saved in the database to carry out “playbacks” to investigate the recent history of the machine system and current status using the corresponding simulation models. In these cases, animations are driven by the historical data acquired, but simultaneously, the reference dynamics models

are used to generate the nominal response of the system with the input data from the historical data. The output data generated by the simulator and from the collected historical data can be visualised and compared using various data analysis and residual analysis techniques. The data visualisation features accomplish the 3-D animation for presenting useful “non-animated” data like electric current and voltage produced both from the simulator and the collected data as an additional means for assisting any monitoring and diagnostic tasks. A fault alarm is generated, for instance, if a residual signal is evaluated to exceed a certain threshold; but more advanced fault detection algorithms can be easily incorporated into MSSS. Figure 4 illustrates schematically the block diagram of the monitoring and fault detection scheme for the actuators and mechanics of a robot manipulator.

### 3.3 Control System Verification

Control system verification is a desirable feature that the simulation models can be used to verify the control programs for testing and verification during

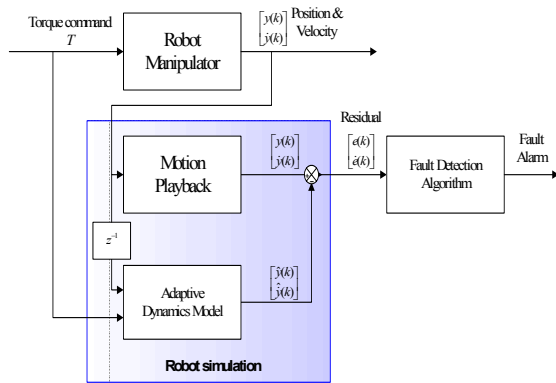

Figure 4: Monitoring and fault detection scheme for the actuators and mechanics of a robot manipulator.

the machine system design, development, commissioning or re-configuration stage. While this functionality has been explored in-depth during the VIR-ENG project, the focus of MASSIVE is to extend the research outcomes from VIR-ENG to support verification of control programs that are developed/modified to cope with maintenance service tasks. Remote download of control code that has been verified in a virtual environment is particularly helpful for the following situations:

- Develop, test and upload temporary control code in the case of temporary reconfiguration due to machine service activities (either preventive or corrective maintenance).
- Remote download of new/modified control code to include additional functions requested by the machine users during the operational phase, e.g. to enhance the performance of the machine or to cope with slight changes in production.

MSSS provides control system verification with two different types of configuration:

- Verification of logic control models and then the logic control code is generated, compiled and subsequently downloaded to the target controller hardware. Verification, testing and simulation are therefore carried out in a pure software environment.
- Verification of the actual control logic hardware and software.

The first configuration type has been developed and demonstrated successfully using languages defined in IEC 61131-3 (1993), in particular Sequential Function Chart (SFC) as the logic control modelling language (see Figure 5). An important research area that has recently been identified is to

extend the concept and implementation to incorporate the function block standard defined in IEC 61499.

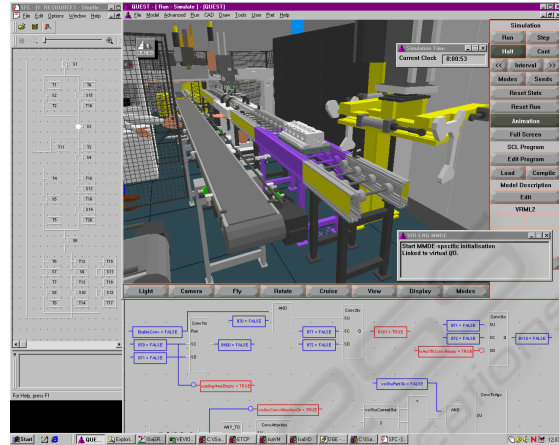

Figure 5: Testing and verification of logic control models using machine simulations.

The integration of real and simulated machine controllers with a simulated model of the machine system in order to test the system’s behaviour, has been identified to be one of the “hot topics” and technology trends of virtual manufacturing (Dépincé et al. 2003). With today’s industrial automation equipment, this integration can be achieved by connecting the simulated machine/environment logic model directly to the machine controller via the OPC client/server-based data access technology. This integration technique has been successfully demonstrated by embedding OPC client functions into a simulation system (Sundberg et al. 2003) using the interfacing technique described in Section 4. The current challenge is to incorporate the OPC communication capability into the unified communication framework selected for integrating all MSSS components (see Section 4).

### 3.4 Scenario Manager

Scenarios Manager is the configuration environment for users to define/create different scenarios, e.g. monitoring scenario, tentative failure or “what if” scenario for diagnosis. It acts as the main user interface for MSSS users to interact with all local system components as well as remote components through the Web service client. The concept of *scenarios* is specifically introduced to allow users to combine various components and sub-models in a very flexible and rapid manner. A scenario is an

abstract “container” that holds any combinations of the following types of software objects:

- A simulation model that is comprised of various sub-models.
- Historical data stream.
- VIO variables to real/simulated control devices/programs.
- Fault detection algorithms that can be applied with the simulation model.
- Data processing and visualisation functions.

The UML (Unified Modelling Languages) class diagram shown in Figure 6 represents the aggregation of a scenario. A *connector* is a software communication mediator that defines the interface for related software objects to communicate with each other, for instance, different types of sub-models, different algorithmic modules for residual analysis and fault detection, possibly developed using a variety of tools and running on a distributed platform. The purpose of having the concept of connectors is twofold. Firstly, it reduces the dependencies among MSSS components; a single component or sub-model can be used and reused in

multiple scenarios without any modifications. Secondly and more importantly, it hides the underlying communication mechanism from the software packages adopted in MASSIVE. In other words, the communication mechanism is encapsulated by the framework that supplies all the communication functions in form of a set of standard libraries.

#### 4 THE COMMUNICATION FRAMEWORK

The following issues have been considered as vital when it comes to the development of the communication framework:

- The suitable communication model for the data flows within a scenario.
- How machine simulation systems are integrated with other applications in order to produce smooth animation effects.

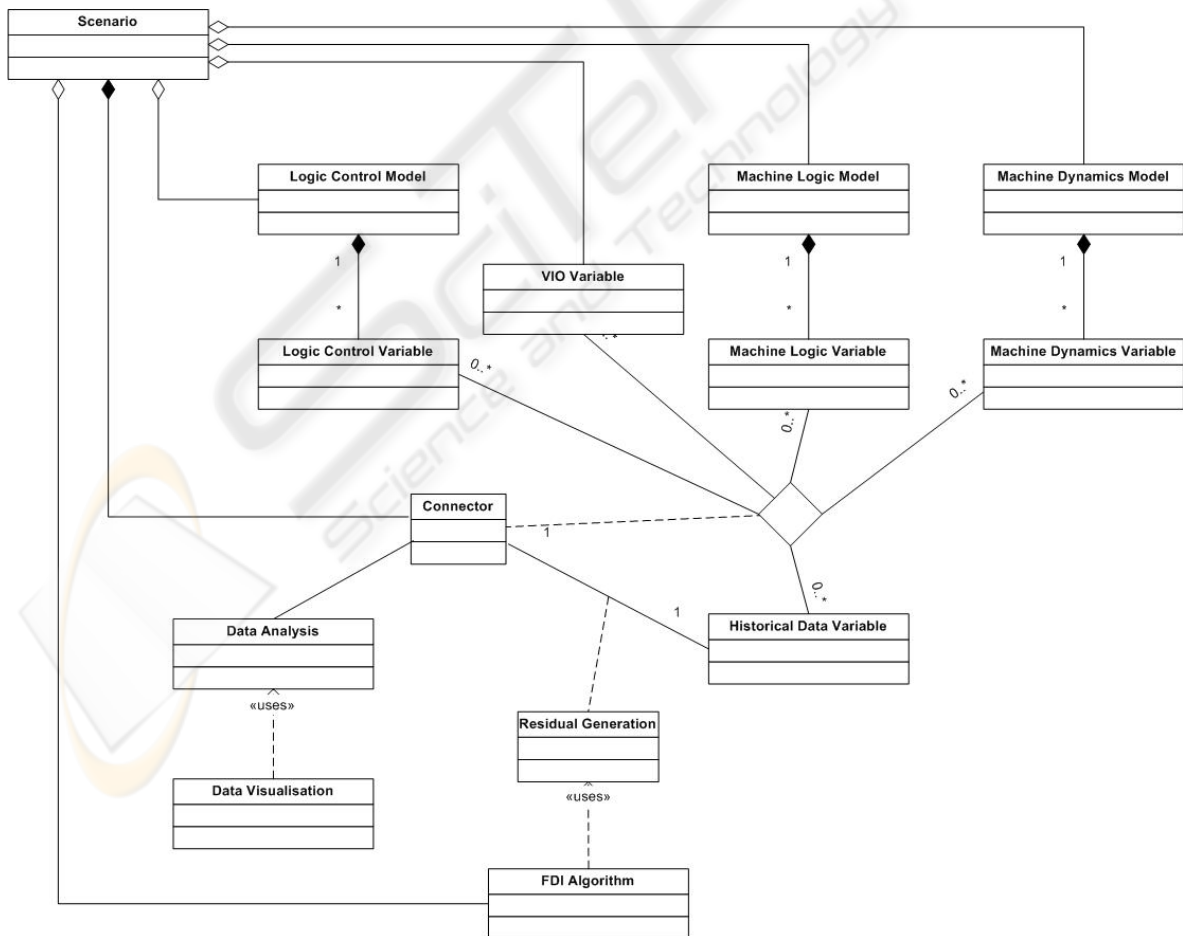

Figure 6: UML class diagram showing the aggregation of a scenario.

- How data integrity and synchronisation is maintained if multiple parties are sharing the data concurrently.

The concept of connectors has suggested the possibility of having some distributed, many-to-many complex data flow patterns when running a scenario. Loose coupling and real-time (deterministic) performance have been identified to be the essential requirements when selecting the communication architecture that supports the implementation of the connectors: it should facilitate the dynamic configuration of data producers from data consumers so that each can act independently of each other; data exchange among applications should also happen anonymously in a distributed platform, without knowing the network locations.

After an extensive investigation into various communication middleware architectures, such as the well-known Microsoft's Distributed Component Object Model (DCOM) and Common Object Request Broker Architecture (CORBA), the Network Data Delivery Services (NDDS) middleware (Pardo-Castellote et al. 1999) supplied by Real-Time Innovations (RTI) commercially has been selected as the most suitable one for developing the communication framework for MSSS. NDDS is developed based on the *publish-subscribe* model that simplifies peer-to-peer and many-to-many communications. Applications use named topics rather than network addresses to distribute data; a publisher simply creates a publication and gives it a topic name. Each subscriber then creates a subscription for the topic name and instructs NDDS what to do when a new issue arrives. A publisher can then update the shared data and notify all subscribers by sending an issue using only a single NDDS function call. Every time the publication has a new issue, NDDS handles the network I/O and transparently sending each issue from the publisher to all subscribers with a declared interest in that topic. Subscribers can therefore be notified when data has been changed and avoid the need for continuous polling. The publish-subscribe model is therefore described as notification-based. The NDDS publish-subscribe model features an open protocol that adjusts automatically as applications join and leave the network. Communications happen anonymously and an application can join and leave the network without the need to notify others; this makes the communications highly fault-tolerant. On the other hand, NDDS provides fast and deterministic data distribution over standard IP networks, whereof the underlying UDP layer handles the data transmission and multicast efficiently. All these features make NDDS a very suitable middleware that satisfies the

requirements for the implementation of the framework.

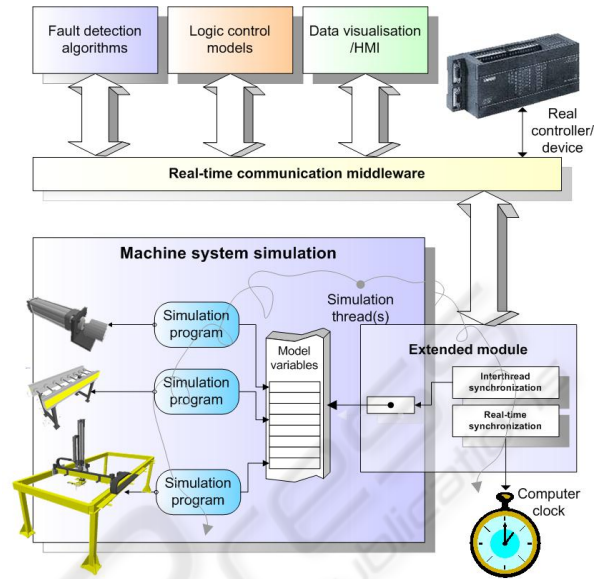

Figure 7: The interfacing method used for integrating simulation programs with other applications.

Initial implementation of a set of standard libraries that supports the simulation systems and different MSSS prototype components to invoke the NDDS services has been completed using the simulation system interfacing technique described in Figure 7. This interfacing technique is characterised by the use of multithreads to detect and handle data updates of model variables that are logically connected to connectors. This relieves the simulation engine from running a polling loop to detect data changes. Together with the real-time capability of NDDS, this results a highly smooth animation effect. A set of experiments has been carried out to quantitatively compare the performance of NDDS with other architectures; NDDS outperforms DCOM noticeably in terms of both update latency and throughput.

## 5 CONCLUSIONS & OUTLOOK

This paper has introduced an innovative virtual engineering framework for supporting the remote monitoring, fault detection and maintenance services of discrete manufacturing machine systems. The core concept behind this framework is the separation of a virtual machine (simulation model) into a number of sub-models including logic control models, machine/environment logic models and machine dynamics models. This separation



facilitates many useful advanced functions to be developed, including control system verification, HIL testing, monitoring by “playback” and model-based fault detection, etc.

This paper has pointed out the importance of a real-time communication framework that provides a highly flexible communication mechanisms among different sub-models and other system components, possibly developed using a variety of tools running on a distributed platform. RTI’s NDDS has been selected as the suitable real-time networking middleware for the development of the underlying communication framework. Based on the publish-subscribe model, NDDS provides many-to-many communications to happen anonymously with network location transparency, which are essential to the implementation of connectors – the concept introduced for maintenance specialists to define multiple monitoring and fault detection scenarios by flexibly connecting multiple sub-models, algorithmic modules and data analysis tools. Future publications will focus on the dynamics modelling techniques and fault-detection algorithms for the real-world industrial test cases within MASSIVE.

## ACKNOWLEDGEMENTS

The authors gratefully acknowledge the Knowledge Foundation (KK Stiftelsen), Sweden, and other industrial participants, including AP&T, DELFOi, Euromation, Volvo Cars and Volvo Powertrain, for the provision of the research funding and their collaborative input to the MASSIVE project. We would also like to acknowledge Real-Time Innovations for the grant of NDDS through our participation in their University Program.

## REFERENCES

- Adolfsson, J., Ng, A. H. C. and Moore, P. R. (2000) Modular machine system design using graphical simulation. In *Proceedings of the 33rd CIRP International Seminar on Manufacturing Systems*, 5-7 June, Stockholm, Sweden, pp 335-340.
- Chen, J. and Patton, R. J. (1999), *Robust model-based fault diagnosis for dynamic systems*, Kluwer Academic Publishers, Dordrecht.
- DELMIA (2003) *IGRIP/Envision & QUEST D5 Release 12*, Dassault Systemes, <http://www.delmia.com>.
- Dépincé, P., Peer-Oliver, W. and Michael, Z. (2003) *Virtual Manufacturing*, MANTYS - Thematic Technology Trend Report.
- Groll, F. (2002) Process visualization and optimization with modern software tools. In *Proceedings of the International Symposium on Robotics*, 7-11 October, Stockholm, Sweden, pp. 193-197.
- IEC 61131-3 (1993) *Programmable controllers - Part 3: programming languages*, International Electrotechnical Commission.
- Isermann, R. and Ballé, P. (1997) Trends in the application of model-based fault detection and diagnosis of technical process, *Control Engineering Practice*, 5 (5), pp. 709-719.
- Lewis, R. (2001) *Modelling control systems using IEC 61499*, The Institution of Electrical Engineers, London, United Kingdom.
- Ljung, L. (1999). *System identification: Theory for the user*, Prentice-Hall, Englewood, Cliffs, New Jersey.
- Moore, P. R., Pu, J., Ng, A. H. C., Wong, C. B., Chong, S. K., Adolfsson, J., Olofsgård, P. and Lundgren, J.-O. (2003) Virtual Engineering: An integrated approach to agile manufacturing machinery design and control, *Journal of Mechatronics*, 13, pp. 1105-1121.
- Nelles, O. (2001) *Nonlinear system identification*, Springer-Verlag, Berlin, Heidelberg.
- OPC Foundation (2003) <http://www.opcfoundation.org>.
- Pardo-Castellote, G., Schneider, S. and Hamilton, M. (1999) *NDDS: The real-time publish-subscribe middleware*, Real-Time Innovations whitepaper, <http://www.rti.com>.
- Sundberg, M., Ng, A. H. C. and de Vin, L. J. (2003) Distributed modular logic controllers for modular conveyor systems. In *Proceedings of the 20th International Manufacturing Conference*, Cork, Ireland, pp. 493-500.
- VIR-ENG (2001) *Integrated design, simulation and distributed control of agile modular manufacturing machinery (VIR-ENG)* ESPRIT Framework IV 25444, final report, Final report, June.
- Wolfram, A. and Isermann, R. (2002) Component based tele-diagnosis approach to a textile machine, *Control Engineering Practice*, 10, pp. 1251-1257.