



David Wang

ABSTRACT

Capacitive sensing is becoming a popular technology to replace optical detection methods and mechanical designs for applications like proximity/gesture detection, material analysis, and liquid level sensing. The main advantages that capacitive sensing has over other detection approaches are that it can sense different kinds of materials (skin, plastic, metal, liquid), it is contactless and wear-free, it has the ability to sense up to a large distance with small sensor sizes, the PCB sensor is low cost, and it is a low-power solution. To understand what kind of applications and the constraints surrounding a system-level design entails, it is important to understand the theory of electrostatics and capacitance calculations. This application note covers the basics of the parallel plate and fringing effect, capacitive sensor design, and ways to adapt the capacitance sensing system within various applications.

Table of Contents

1 Capacitance Measurement Basics	2
2 Capacitive Sensing - How it Works	3
3 Capacitive Sensing Versus Capacitive Touch	4
4 FDC1004 Theory of Operation	4
5 FDC1004 Use Cases	5
6 Capacitive Sensor Topologies	7
7 Getting Started: Design Guidelines, Tips and Principles	10
8 Revision History	11

List of Figures

Figure 1-1. Parallel Plate Capacitor.....	2
Figure 1-2. Electric Fields of a Parallel Plate Capacitor.....	3
Figure 2-1. Basic Implements for Capacitive Sensing.....	3
Figure 4-1. FDC1004 Capacitive Sensing Theory of Operation.....	4
Figure 5-1. Independent Channel use Case for Gesture Sensing Application.....	5
Figure 5-2. Differential or Ratiometric Measurements Example, Liquid Level.....	6
Figure 5-3. Remote Sensing Example.....	6
Figure 5-4. Time-Varying Offset Measurements Example.....	7
Figure 5-5. Car Door Proximity Example.....	7
Figure 6-1. Parallel Plate Topology For Material Analysis.....	8
Figure 6-2. Parallel Fingers (GND-Sensor) Topology.....	8
Figure 6-3. Central Ground, Central Sensor Symmetry.....	9
Figure 6-4. Comb Sensor Design.....	9
Figure 6-5. Single Sensor Topology for Human Recognition.....	10
Figure 7-1. Shield Configurations.....	11

List of Tables

Table 3-1. Capacitive Touch Versus Capacitive Sensing Requirements.....	4
---	---

1 Capacitance Measurement Basics

Capacitance is the ability of a capacitor to store an electrical charge. A common form – a parallel plate capacitor – the capacitance is calculated by $C = Q / V$, where C is the capacitance related by the stored charge Q at a given voltage V . The capacitance (measured in Farads) of a parallel plate capacitor (see [Figure 1-1](#)) consists of two conductor plates and is calculated by:

$$C = \frac{\epsilon_r \times \epsilon_0 \times A}{d} \quad (1)$$

Equation 1 is characterized by:

- A is the area of the two plates (in meters)
- ϵ_r is the dielectric constant of the material between the plates
- ϵ_0 is the permittivity of free space (8.85×10^{-12} F/m)
- d is the separation between the plates (in meters)

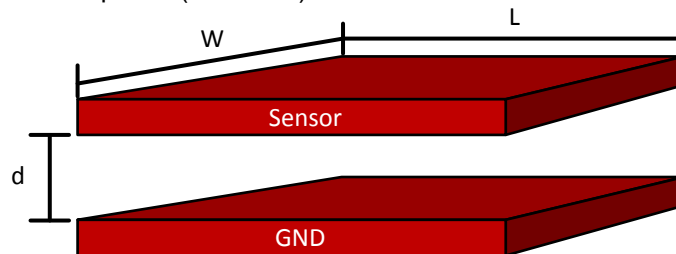

Figure 1-1. Parallel Plate Capacitor

The plates of a charged parallel plate capacitor carry equal but opposite charge spread evenly over the surfaces of the plates. The electric field lines start from the higher voltage potential charged plate and end at the lower voltage potential charged plate. The parallel plate equation ignores the fringing effect due to the complexity of modeling the behavior but is a good approximation if the distance (d) between the plates is small compared to the other dimensions of the plates so the field in the capacitor over most of its area is uniform. The fringing effect occurs near the edges of the plates, and depending on the application, can affect the accuracy of measurements from the system. The density of the field lines in the fringe region is less than directly underneath the plates since the field strength is proportional to the density of the equipotential lines. This results in weaker field strength in the fringe region and a much smaller contribution to the total measured capacitance. [Figure 1-2](#) displays the electric fields lines path of a parallel plate capacitor.

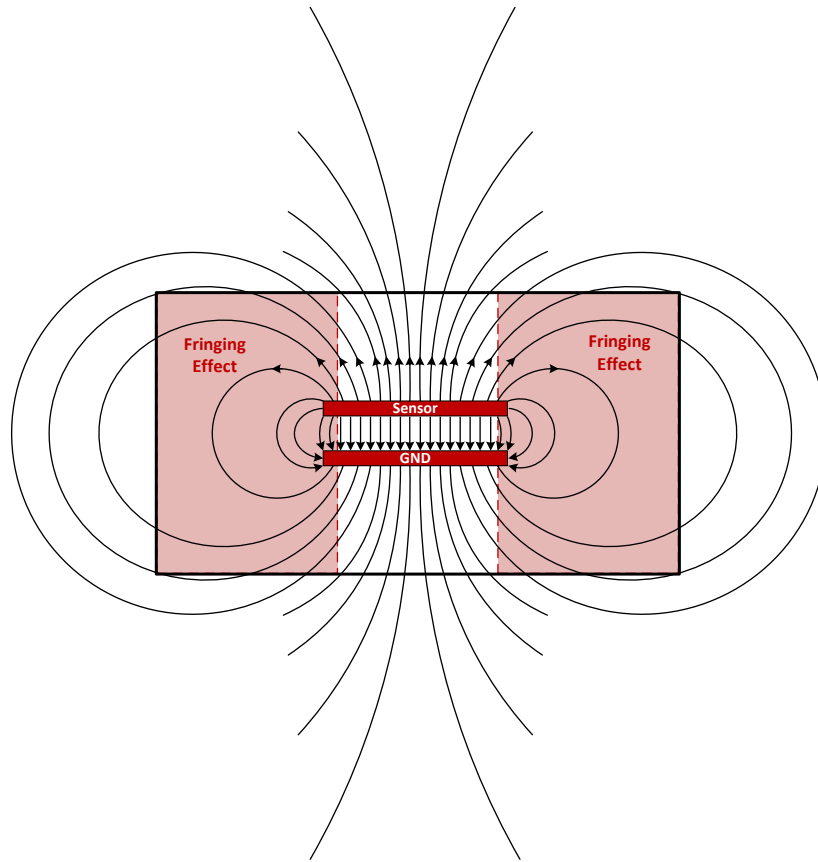

Figure 1-2. Electric Fields of a Parallel Plate Capacitor

2 Capacitive Sensing - How it Works

Capacitive sensing is a technology based on capacitive coupling that takes the capacitance produced by the human body as the input. It allows a more reliable solution for applications to measure liquid levels, material composition, mechanical buttons, and human-to-machine interfaces. A basic capacitive sensor is anything metal or a conductor and detects anything that is conductive or has a dielectric constant different from air. [Figure 2-1](#) displays three basic implementations for capacitive sensing: proximity/gesture recognition, liquid level sensing, and material analysis. More details about the sensor topology can be found in the [Capacitive Sensor Topologies](#) section.

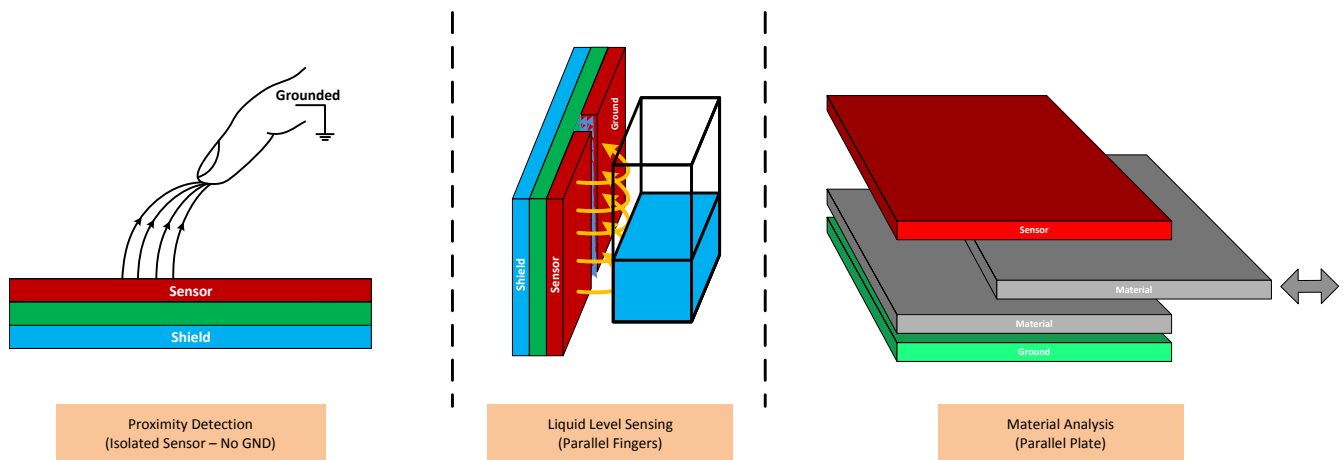

Figure 2-1. Basic Implements for Capacitive Sensing

3 Capacitive Sensing Versus Capacitive Touch

Capacitive sensing has similar and overlapping concepts compared to capacitive touch. Capacitive sensing can be used for touch applications and capacitive touch can be used for capacitive sensing applications, but this is misleading to users since there are advantages and limitations between devices designed for the two separate applications. Some typical requirements are shown in [Table 3-1](#). Depending on the system requirements, a particular device may not be suitable for touch or sensing applications.

Table 3-1. Capacitive Touch Versus Capacitive Sensing Requirements

Requirements	Capacitive Touch	Capacitive Sensing
Channel count	High (> 8)	Low (< 4)
Resolution	Low	High
Typical distance	2 to 3 mm	Up to 70 cm
Sensitivity	10s to 100s fF	< 1 fF
Requires contact	Yes	No
Power consumption	μ A to mA range	μ A range

4 FDC1004 Theory of Operation

The FDC1004's basic operation of capacitive sensing implements a switched capacitor circuit to transfer charge from the sensor electrode to the sigma-delta analog to digital converter (ADC), as shown in [Figure 4-1](#). A 25-kHz step waveform is driven on the sensor line for a particular duration of time to charge up the electrode. After a certain amount of time, the charge on the sensor is transferred to a sample-hold circuit. The sigma-delta ADC converts the analog voltage into a digital signal. Once the ADC completes its conversion, the result is digitally filtered and corrected depending on gain and offset calibrations.

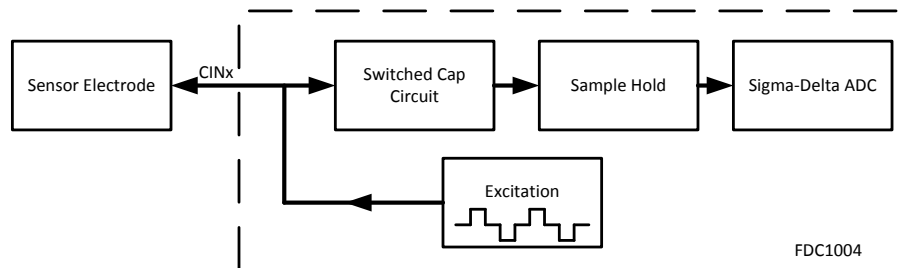

Figure 4-1. FDC1004 Capacitive Sensing Theory of Operation

5 FDC1004 Use Cases

There are several use cases that the FDC1004 provides significant advantages due to the device specifications and design features. The four important use cases include:

1. Independent channels
2. Differential or ratiometric measurements
3. Remote sensing
4. Time-varying offset measurements

5.1 Independent Channels

The FDC1004 features 4 independent channels that are sampled sequentially in a time-multiplexed manner. The use of independent channels allows the measurement from each channel to be unaffected by the other channels parasitic capacitance and noise. It also enables the system to compensate for capacitive variances and offsets individually. Each channel has an input capacitance range C_{IN} of ± 15 pF and offset capacitance range C_{OFFSET} up to 100 pF (user-programmed using the CAPDAC feature). Typical applications include rain sensing, proximity/gesture detection, and water/ice/snow detection.

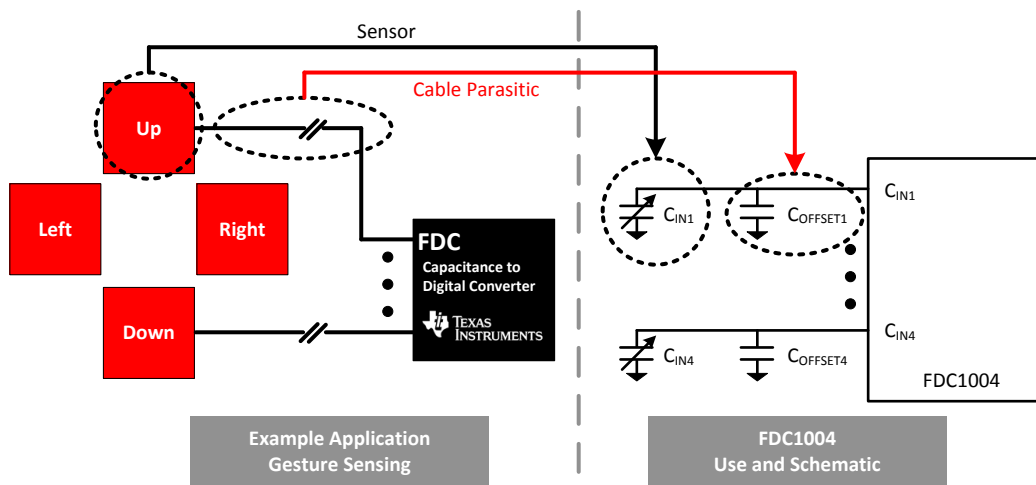

Figure 5-1. Independent Channel use Case for Gesture Sensing Application

5.2 Differential and Ratiometric Measurements

Differential measurements are performed to obtain an accurate capacitance measurement difference between two sensors. This is applicable to environmental factors that can cause variations in capacitance. At least one channel (environmental sensor) monitors changes in dielectric due to factors such as temperature, humidity, material type, and stress on the material, while the second and third channel is the level and reference sensor, respectively. Ratiometric measurements, in terms of liquid level sensing, is the ratio or difference between the level sensor and reference since the level capacitance is proportional to liquid height. The liquid level must be higher than the reference sensor height in order to have liquid and temperature independent measurement system.

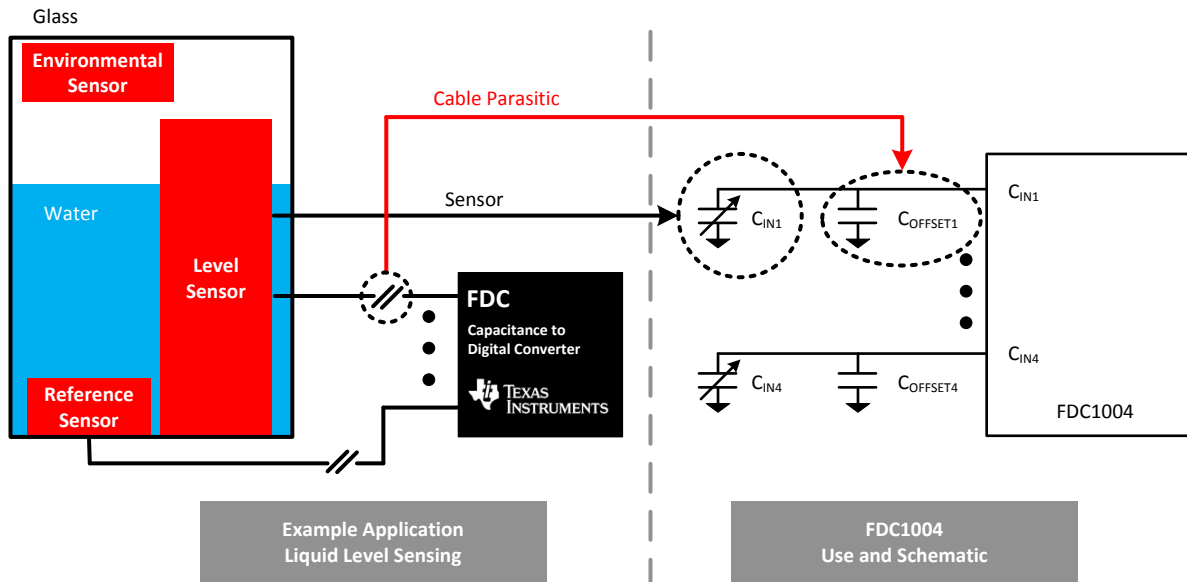

Figure 5-2. Differential or Ratiometric Measurements Example, Liquid Level

5.3 Remote Sensing

The FDC1004 can be used in system designs that require remote sensing. The distance between the sensor and FDC1004 may be on the order of 1 to 100 meters and is a major issue when accurate capacitance measurements are needed. Cable lines pick up any external interference seen along the line so the signal path distance between the sensor and FDC1004 should be as short as possible. To compensate for long signal paths, the FDC1004 allows parasitic capacitance compensation up to 100 pF. The 100-pF compensation gives the FDC1004 the ability to drive a twisted pair up to 1600 m (60 fF/m) or drive a coax cable up to 1.5 m (66 pF/m). It is possible to use external capacitors on the input CIN pins to ground to stabilize the capacitance within the FDC1004 input capacitance range if a larger offset is required.

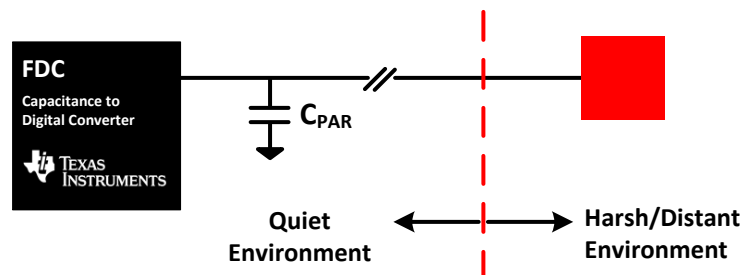

Figure 5-3. Remote Sensing Example

5.4 Time-Varying Offset Measurements

As compared with differential measurements, the FDC1004 can be used in the case where time-varying offset measurements are required to be monitored. A replica sensor adjusts for changes in offset from factors like humidity, environment, and water/ice/snow. This external offset automatically adjusts and allows CIN to vary from 0 to 115 pF. An example application that would contain time-varying offsets includes proximity/gesture detection in the presence of water/ice/snow for car door handles as shown in Figure 5-5. A single proximity gesture sensor fails in the presence of rain/snow/ice since the offset value can vary and create a false trigger for the system. Adding an environmental sensor the same size as the main sensor, which only tracks the rain/snow/ice, automatically adjusts to the changing environment. A differential measurement can then be used to determine the capacitance only from the intended target, the user's hand.

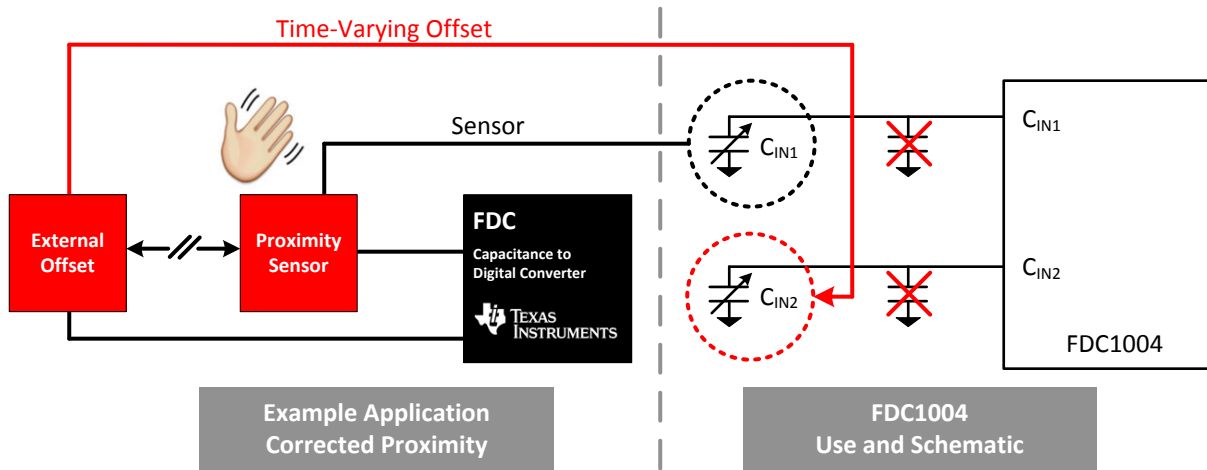

Figure 5-4. Time-Varying Offset Measurements Example

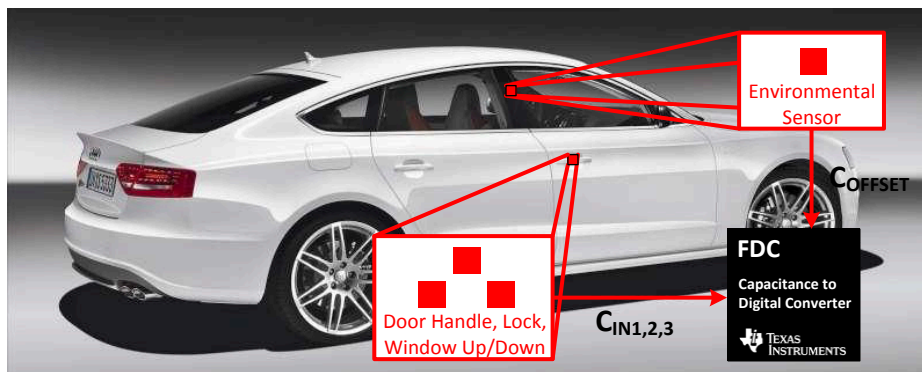

Figure 5-5. Car Door Proximity Example

6 Capacitive Sensor Topologies

There are several capacitive sensor topologies that are common depending on the application. The sensor topology depends on:

- Sensor-to-target distance
- Dielectric constant of target
- Desired sensitivity

The basic topologies include:

- Parallel plate
- Parallel fingers
- Single sensor for human recognition

6.1 Parallel Plate

The parallel plate topology works exactly as described by the parallel plate capacitor equation. The high density of electric fields between the two plates allows high sensitivity. Example applications for this topology are material analysis and paper stack height sensing. For material analysis, the capacitance between the plates will change depending on the difference of dielectric constant from material to material. The high resolution from the FDC1004 allows a sensitivity range that can detect very small changes in dielectric. For paper stack height sensing, the capacitance will increase as the number of sheets of paper are inserted between the plates. The difference between the air spacing and the paper spacing (due to the dielectric change and the known height of the paper and air spacing) allows the capacitance to be calculated.

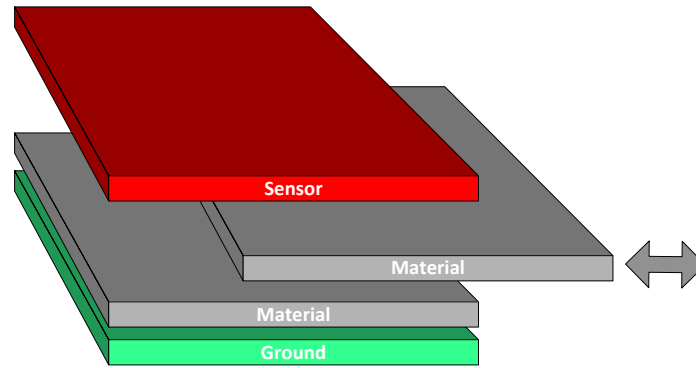

Figure 6-1. Parallel Plate Topology For Material Analysis

6.2 Parallel Fingers

The parallel fingers (GND-sensor) topology works under the principle of fringing capacitance. High sensitivity along the z-axis (see Figure 6-2) of the sensors enables this topology to be implemented in liquid level sensing applications. The electric field lines are more dominant near the edges between the sensor and ground plates. The capacitance calculations are not as straightforward as the simple parallel plate form but the sensitivity of the sensors increases as sensor size increases (non-linearly). A shield on the backside of the main sensor and GND electrode provides directivity towards the target.

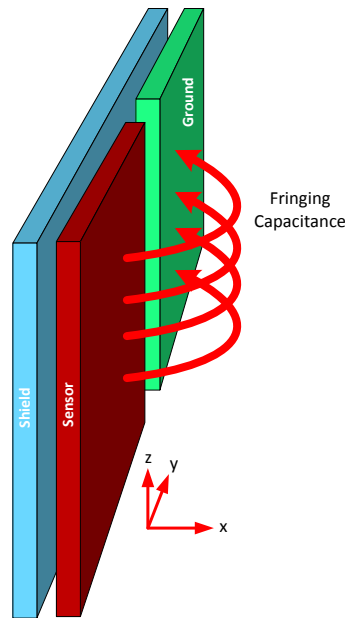

Figure 6-2. Parallel Fingers (GND-Sensor) Topology

Several variant configurations can be designed with the parallel fingers. Figure 6-2 displays the GND-sensor configuration. Multiple sensor and ground electrodes can be alternated to have a central ground or sensor symmetry, as shown in Figure 6-3. A central ground is required for a wide directivity along the width of the electrodes and gives the widest response. A central sensor electrode is required for high directivity along the width of the electrodes and provides the sharpest response. The comb configuration, as shown in Figure 6-4, is comprised of both of these variants and very effective for wide and high directivity. The comb configuration is typically used in rain sensor applications and other applications that require a large sensing area and high sensitivity/resolution.

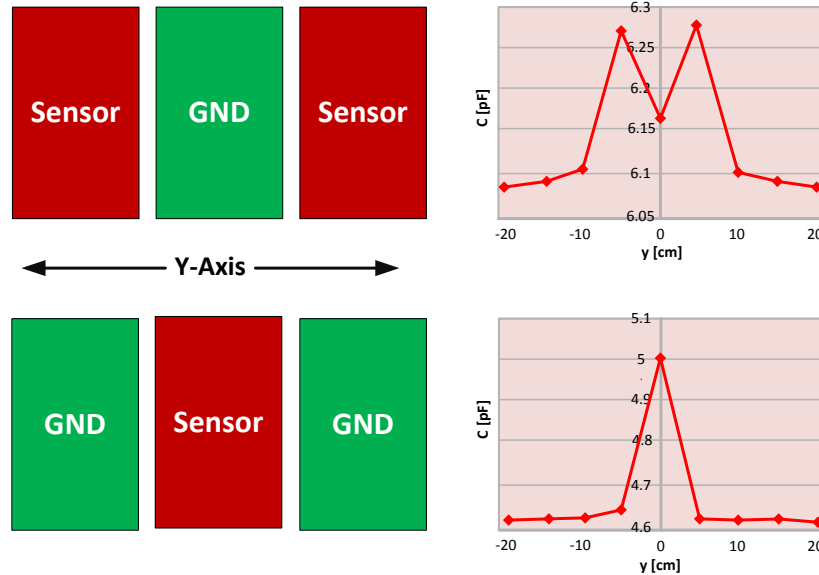

Figure 6-3. Central Ground, Central Sensor Symmetry

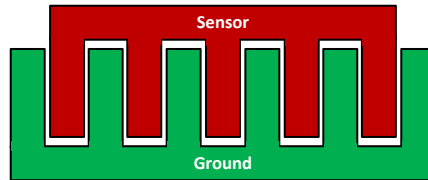

Figure 6-4. Comb Sensor Design

6.3 Single Sensor for Human Recognition

The single sensor design for human recognition uses the same fringe capacitance principles as the parallel fingers topology except that the human hand or finger substitutes the ground electrode. Since the human body is grounded, the fringing electric field lines stray from the sensor to the hand as the hand approaches the sensor. This technique behaves similarly to the parallel plate equation since the distance between the sensor and GND (hand) electrodes is the only changing parameter. The capacitance increases as the hand gets closer to the sensor, but in a non-linear way because of fringing effects. The presence of the shield electrode underneath the sensor electrode helps reduce EMI and parasitic capacitances effects as shown in Figure 6-5 and to the side of the sensor.

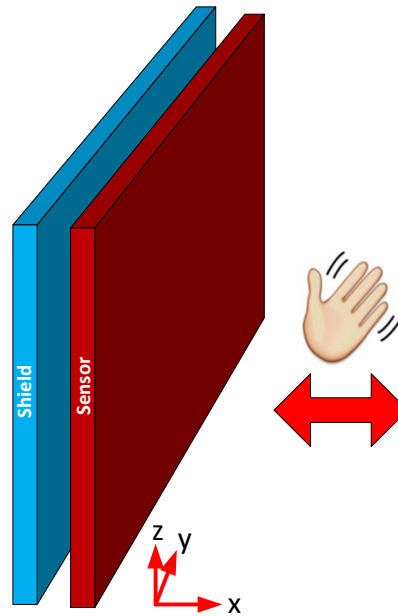

Figure 6-5. Single Sensor Topology for Human Recognition

7 Getting Started: Design Guidelines, Tips and Principles

There are many system-level factors that will cause inconsistency and inaccuracy of the capacitance measurements. The following sections describe design guidelines for the FDC1004 and for the sensor/shield to maximize sensing performance and quality.

7.1 FDC1004 Layout

The FDC1004 measures the capacitances connected between the CINx (CIN1 through CIN4) pins and GND. To get the best result, locate the FDC1004 as close as possible to the capacitive sensor. Minimize the connection length between the sensor and FDC1004 CINx pins and between the sensor ground and the FDC1004 GND pin. If a shielded cable is used for remote sensor connection, the shield should be connected to the SHLDx (SHLD1 or SHLD2) pin according to the configured measurement. The ground plane needs to be far from the channel traces. A ground plane is mandatory around or below the I2C pins.

7.1.1 Acceptable and Unacceptable Practices

Avoid long traces to connect the sensor to the FDC1004. Traces and cables pick up any parasitic capacitance and noise along the line. Short traces reduce parasitic capacitances between shield versus input channel and parasitic resistance between input channel versus GND and shield versus GND. Traces should also be shielded with the appropriate shield output depending whether the measurement is single-ended or differential.

Since the sensor in many cases is simply a metal surface on a PCB, it needs to be protected with solder resist to avoid short circuits and limit any corrosion. Any change in the sensor may result in a change in system performance.

7.2 Sensor and Shield Design Layout

Sensor and shield design layouts are two important concepts that determine the sensitivity, range, and signal quality of the capacitance measurements. The two primary applications for capacitive sensing are liquid level sensing and proximity/gesture detection. 2D and 3D finite element analysis simulations can aid in determining the appropriate sensor size. If this capability is not possible, the suggestions in this section can be used as guidelines.

7.2.1 Liquid Level Sensing

The main topology for liquid level applications is the parallel finger as shown in [Figure 6-2](#). Use the following tips on how different parameters are affected by changing the sensor size properties:

- Larger sensor size area increases sensitivity and dynamic range of the measurements.

- Minimize the gap between the sensor and the water to allow sufficient sensitivity or increase sensor area.
- Increasing the gap spacing between the sensor and GND electrode slightly increases sensitivity and dynamic range. Only valid if the spacing of the electrodes to the water is minimized.
- Use the Out-Of-Phase technique to mitigate interference from grounded objects like the human hand so capacitance measurements are not severely affected.

7.2.2 Proximity/Gesture Detection

The main topology for proximity and gesture detection is the isolated sensor as shown in [Figure 7-1](#). See the following tips on how different parameters are affected by changing the sensor size properties:

- Larger sensor size area increases sensitivity and dynamic range of the measurements, but higher chance for the sensor to be affected by any noise or interference in the surrounding environment.
- Minimizing the distance between the sensor and shield electrode ensures better coupling and effectiveness, but sensitivity and dynamic range decreases.
- The parallel fingers approach used for liquid level sensing works best when the target is ungrounded.
- The isolated sensor approach works best when the target is grounded.

7.2.3 Active Shielding

An active shield coupling with the sensor helps mitigate interference and parasitic capacitances seen along the sensor signal path from the electrode to the input of the FDC1004. It also helps to focus the target direction in a specific area. A shield electrode can be paired with the sensor electrode in several ways and affects the measurement parameters differently compared to the absence of a shield electrode:

- A shield the same size as the sensor electrode placed directly underneath the sensor.
- A shield larger than the sensor electrode placed directly underneath the sensor.
- A shield ring wrapped around the top side adjacent to the sensor with a shield underneath the sensor.

The shield blocks interference from the bottom and side proximity of the sensor. As the shield size increases, the effect from interference decreases but the sensitivity and dynamic range of the capacitance measurements for top, side, and bottom proximity also decreases. Minimizing the distance between the sensor and shield electrode ensures better coupling and effectiveness. The shield must be sized accordingly, depending on how much margin is allocated for interference and parasitics.

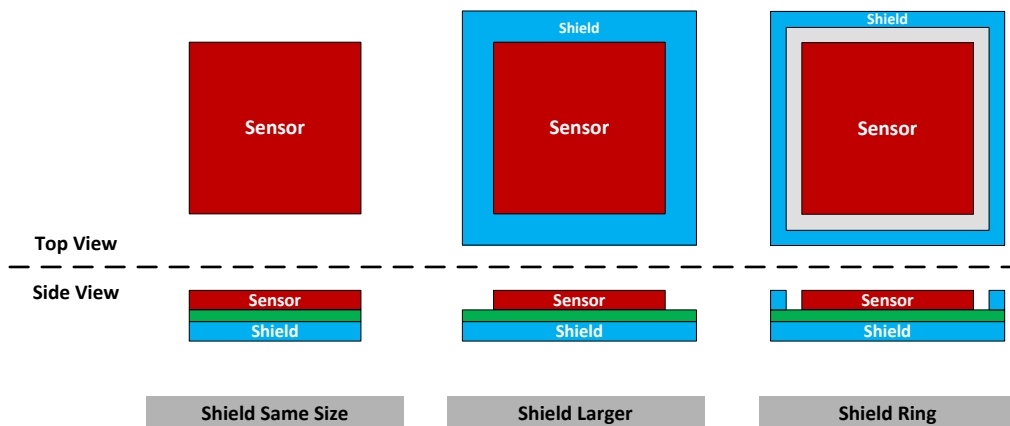

Figure 7-1. Shield Configurations

8 Revision History

NOTE: Page numbers for previous revisions may differ from page numbers in the current version.

Changes from Revision * (December 2014) to Revision A (June 2021)	Page
• Updated the numbering format for tables, figures and cross-references throughout the document.....	2

IMPORTANT NOTICE AND DISCLAIMER

TI PROVIDES TECHNICAL AND RELIABILITY DATA (INCLUDING DATA SHEETS), DESIGN RESOURCES (INCLUDING REFERENCE DESIGNS), APPLICATION OR OTHER DESIGN ADVICE, WEB TOOLS, SAFETY INFORMATION, AND OTHER RESOURCES "AS IS" AND WITH ALL FAULTS, AND DISCLAIMS ALL WARRANTIES, EXPRESS AND IMPLIED, INCLUDING WITHOUT LIMITATION ANY IMPLIED WARRANTIES OF MERCHANTABILITY, FITNESS FOR A PARTICULAR PURPOSE OR NON-INFRINGEMENT OF THIRD PARTY INTELLECTUAL PROPERTY RIGHTS.

These resources are intended for skilled developers designing with TI products. You are solely responsible for (1) selecting the appropriate TI products for your application, (2) designing, validating and testing your application, and (3) ensuring your application meets applicable standards, and any other safety, security, regulatory or other requirements.

These resources are subject to change without notice. TI grants you permission to use these resources only for development of an application that uses the TI products described in the resource. Other reproduction and display of these resources is prohibited. No license is granted to any other TI intellectual property right or to any third party intellectual property right. TI disclaims responsibility for, and you will fully indemnify TI and its representatives against, any claims, damages, costs, losses, and liabilities arising out of your use of these resources.

TI's products are provided subject to [TI's Terms of Sale](#) or other applicable terms available either on ti.com or provided in conjunction with such TI products. TI's provision of these resources does not expand or otherwise alter TI's applicable warranties or warranty disclaimers for TI products.

TI objects to and rejects any additional or different terms you may have proposed.

Mailing Address: Texas Instruments, Post Office Box 655303, Dallas, Texas 75265
Copyright © 2022, Texas Instruments Incorporated